

MACHINE TOOL SPINDLE BEARING SELECTION & MOUNTING GUIDE



Content

Introduction	4	Post-Mounting	
Bearing Selection		Preload Checks	46
Overview	6	Alignment and Balance	48
NSK Super Precision Bearings –		Running In	49
Product Range	8	Trouble Shooting	50
Identification Marks	10	› Cause of High Temperature	50
Contact Angle	12	› Cause of Noise	51
Universal Sets	14	Upgrading	
Precision Grades	15	Overview	52
Preload	16	Robust Design	54
Bearing Matching	22	Improved Steel	56
Pre-Mounting		Sealed Bearings	57
Cleanliness and Washing	24	Hybrid Bearings	61
Greasing Process	26	TYN Cages	62
Grease Quantities	27	TAC Thrust Bearing Conversions	63
Component Checks	28	TB Cages	64
Mounting		Supplementary Information	
Fitting Bearings to Shaft	30	Bearing Interchange Guide	66
Locknut Torques	32	Bearing Failure Countermeasures	68
Spindle Runout Checks	32	Sound and Vibration Diagnosis	73
Fitting Spindle to Housing	34	Bearing Preload Conversion Tables	76
Mounting Tapered Bore Roller Bearings	36	Bore and OD Matching Chart	82
› Calculation Method	36	Useful Tips	85
› Gauge Method	40	Index	86
Classical Spindle Arrangements	42		
Summary of Spindle Arrangements	43		
› Heavy Duty Spindle	44		
› Medium to High-Speed Spindle	45		

As one of the world's leading manufacturers of rolling bearings, linear technology components and steering systems, we can be found on almost every continent – with production facilities, sales offices and technology centres – because our customers appreciate short decision-making channels, prompt deliveries and local service.



The NSK company

NSK commenced operations as the first Japanese manufacturer of rolling bearings back in 1916. Ever since, we have been continuously expanding and improving not only our product portfolio but also our range of services for various industrial sectors. In this context, we develop technologies in the fields of rolling bearings, linear systems, components for the automotive industry and mechatronic systems. Our research and production facilities in Europe, Americas and Asia are linked together in a global technology

network. Here we concentrate not only on the development of new technologies, but also on the continuous optimisation of quality – at every process stage.

Among other things, our research activities include product design, simulation applications using a variety of analytical systems and the development of different steels and lubricants for rolling bearings.

Partnership based on trust – and trust based on quality

Total Quality by NSK: The synergies of our global network of NSK Technology Centres. Just one example of how we meet our requirements for high quality.

NSK is one of the leading companies with a long tradition in patent applications for machine parts. In our worldwide research centres, we not only concentrate on the development of new technologies, but also on the continual

improvement of quality based on the integrated technology platform of tribology, material technology, analysis and mechatronics.

More about NSK at www.nskeurope.com or call us on +44 (0)1636 605123



Introduction

The successful build of a spindle will depend on close attention to details as illustrated below:

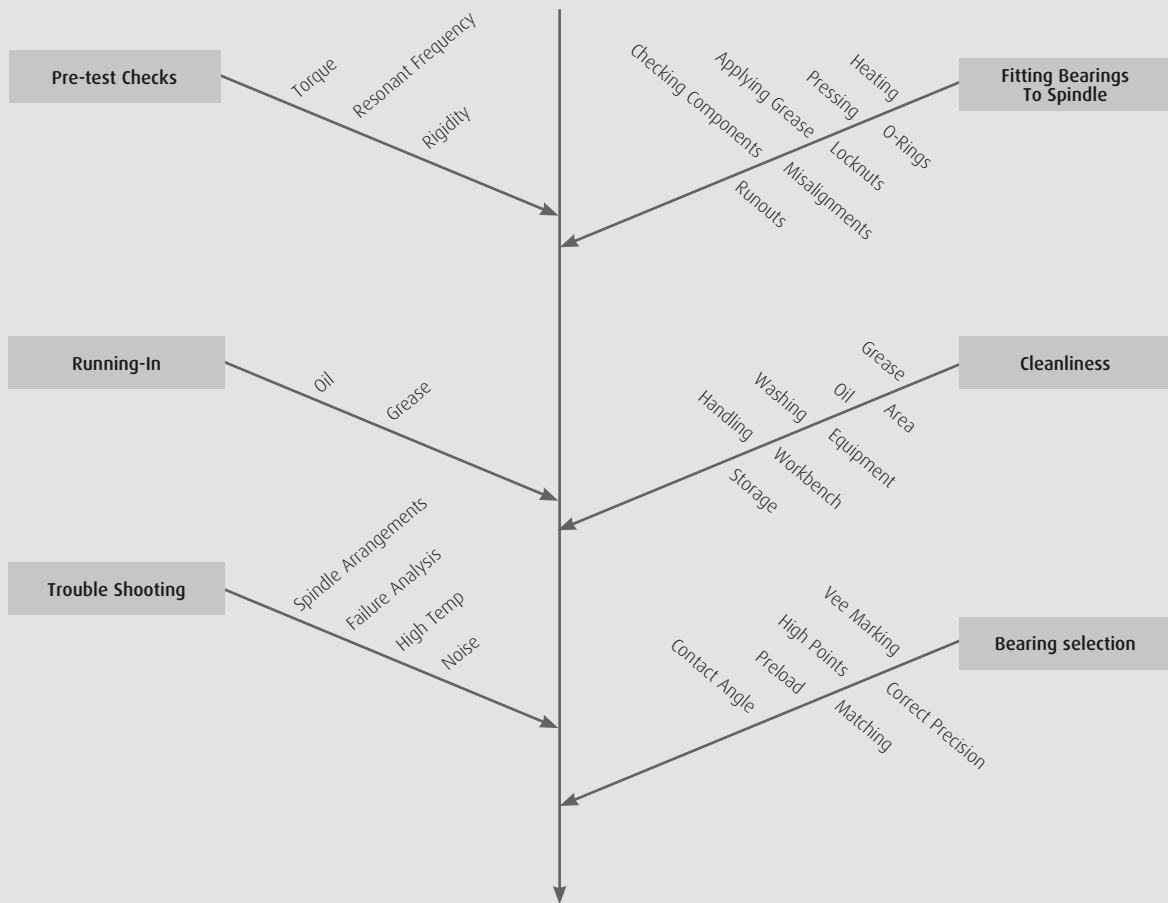



Machine Tool Precision bearings are very accurately engineered components and as such are very important to the successful performance of the machine tool. The way in which a bearing is handled and fitted to a machine tool does not only determine if the machine operates accurately but can also affect the life of the bearing in the spindle.

This catalogue is intended to be a comprehensive guide to anyone who fits bearings to a machine tool regardless to whether it is in planned maintenance or reactive to a breakdown. This catalogue follows a logical progression through selection of the correct bearing types, to the importance of cleanliness before attempting to assemble the spindle. A detailed part of assembly procedures is included with many photographs and drawings. Pre-test checks, 'running in' and trouble shooting is also included to allow the builder more scope in solving spindle problems.

A further section called Upgrading is included to explain how to improve both the performance and most of all the reliability of a spindle. In nearly all cases this can be simply done by replacing the bearing and no changes being necessary to the actual spindle design.

Some sections include a useful tip like the one shown below, these tips are based on many years of experience and can be particularly useful for newcomers to the spindle repair business and a good reminder to the more experienced engineers.

Bearing Selection Overview

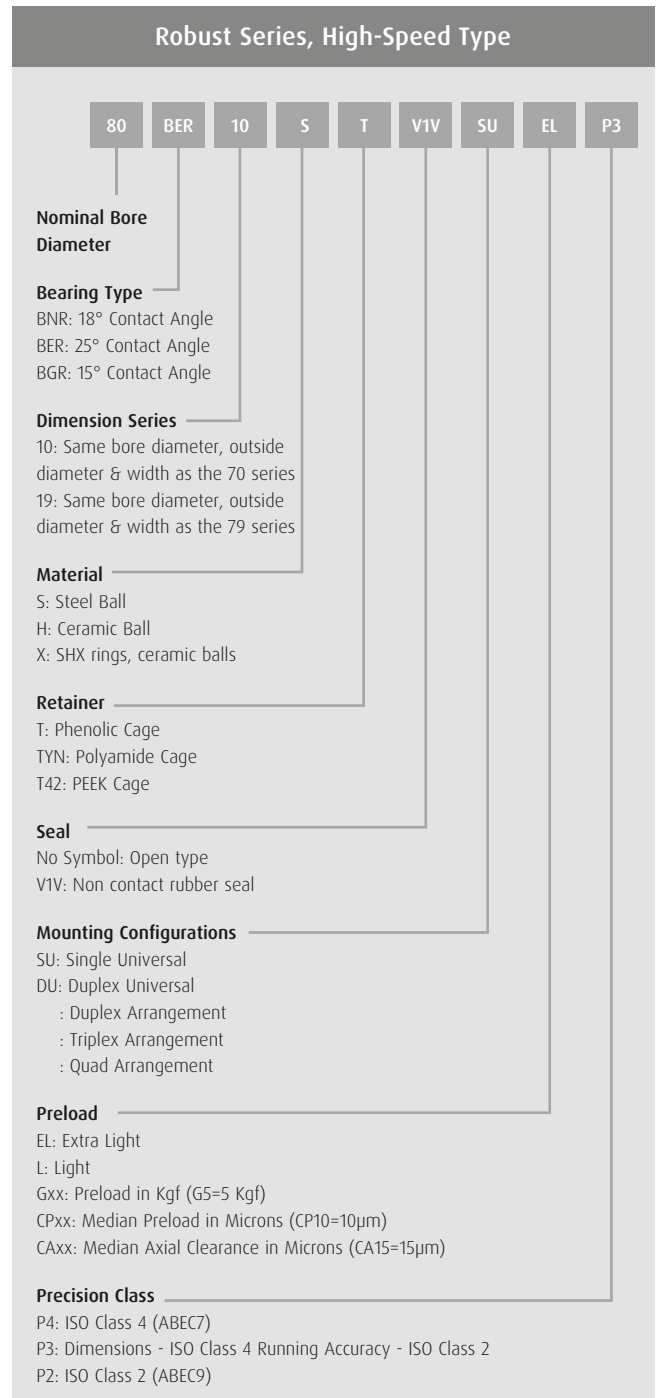
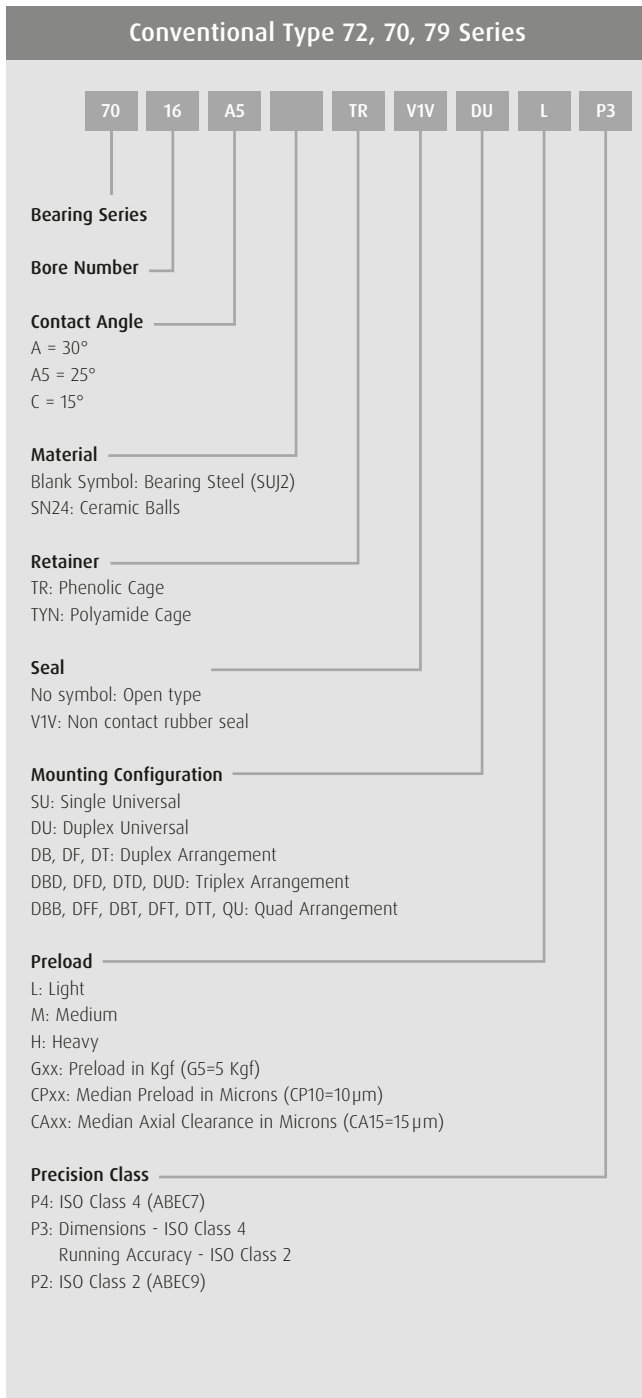

* For inch series bearings, the fractional portion of the size is omitted.

† CC0 clearance (NSK's recommended clearance)

CC0 clearance range less than CC1. This range overlaps with the upper values of CC9 and lower values of CC1, as this clearance is easy for customers to target this range, it is the preferred clearance offered for CRB with taper bore.

CC1 clearance

Matched clearance range greater than CC0. While not the standard, this clearance is most popular in the field.



Thrust Angular Contact Ball Bearing

100 BAR 10 S TYN DB L P4A

Bearing Bore Diameter (mm)

Bearing Type

BAR: 30° Contact Angle
BTR: 40° Contact Angle

Dimension Series

10: Arranged with NN30XX Series

Material

S: Steel Ball | H: Ceramic Ball

Retainer

TYN: Polyamide Cage

Combination

DB: Back to Back Duplex

Preload

L: Standard Preload
EL: Standard Preload for High-Speed Applications
CP: Special Preload
CA: Special Axial Clearance

Precision Class

P4A: ISO Class 4, O.D. is Special
P2A: ISO Class 2, O.D. is Special

140 TAC 20D PN7 +L C6

Bearing Bore Diameter (mm)

Bearing Type

Dimension Series

20D: High-Speed Type
w/Revised Internal Features
29D: High-Speed Type
w/Revised Internal Features

Precision Class

PN7: ISO Class 4, O.D. is Special

Spacer (Inner Ring)

Preload Class

C6: Standard Preload for Grease Lubrication
C7: Standard Preload for Oil Lubrication

TAC size range from 140mm to 280mm. Please see page 65 showing how to upgrade from old TAC to new BTR/BAR for sizes from 35mm to 130mm bore.

Cylindrical Roller Bearings

NN 3 0 17 MB KR E44 CCO P4

Cylindrical Roller Designator

NN: Double Row, Inner Ring Guided Rollers
N: Single Row, Inner Ring Guided Rollers

Width Series

Diameter Series

Bore code

Material

single row only { RS: Bearing Steel (SUJ2) (rings and rolling elements)
RX: Heat Resistant Steel (SHX) (rings and rolling elements)
RXH: Heat Resistant Steel (SHX) for rings and ceramic rolling elements
No symbol: SUJ2 steel

Retainer

MB: Roller guided machined brass cage (Double Row)
TB: Roller guided PPS resin cage (Double Row)
TP: Outer ring guided PEEK resin cage
MR: Roller guided machined brass cage (Single Row)

Bore Configuration

KR: Ultra Precision Tapered Bore (1:12)
Blank symbol: Cylindrical bore

Lubrication

E44: Outer ring with machined lubrication groove and holes (Double Row Only)

Radial Clearance

CC1: Standard clearance for cylindrical bore
CC0: Standard clearance for tapered bore
CCG: Special radial clearance

Precision Class

P2: ISO Class 2 | P4: ISO Class 4

Ball Screw Support Bearings

30 TAC 62 B DDG SU C10 PN7B

Bearing Bore* (mm)

Bearing Type

Bearing O.D.* (mm)

Internal Design

B: High Capacity and Higher Speed (Replaces "A" type)

Seal Symbol

No symbol: Open type
DDG - Low friction contacting seal

Mounting Configuration

SU: Single Universal
DU: Duplex Universal
DB, DF, DT: Duplex Arrangement
DBD, DFD, DTD, DUD - Triplex Arrangement
DBB, DFF, DBT, DFT, DTT, QU - Quad Arrangement

Preload

C10: Metric Series - Standard Preload
C11: Inch Series
C9: Light Preload

Precision Class

PN7A: Standard Accuracy (Equivalent to ISO Class 4)
PN7B: Special Accuracy (Bore diameter and OD are exclusive to NSK. Equivalent to ISO Class 4. For SU arrangement only.)

Bearing Selection

NSK Super Precision Bearings – Product Range

Several types of super precision bearings are available from NSK, including the ROBUST series of high performance bearings, the special series of bearings for unique and specialised applications, and the standard series bearings.



Standard Series

High Precision Angular Contact Ball Bearings

Basic NSK super precision bearings manufactured to conform to ISO standards.

- › 70xx, 72xx, 79xx series
- › Three types of contact angle: 15° (C), 25° (A5), 30° (A)
- › Two types of cage design: Select either phenolic (TR) or polyamide (TYN), depending on application requirements
- › Two types of ball material: Steel and Ceramic (SN24)



Robust Series BNR, BER Series

Ultra High-Speed Angular Contact Ball Bearings

High performance bearings developed for high-speed operation with low temperature rise. Suitable for ultra high precision machining applications, and ultra high-speed applications.

- › Two types of contact angle: 18° (BNR), 25° (BER)
- › Two types of ball material: Steel (S type) and Ceramic (H and X type)
- › Two types of cage design: Select either phenolic (T) or polyamide (TYN), depending on application requirements
- › ROBUST series also can be used for ultra high speed applications of over 3 million $d_m n$.



Robust Series BAR, BTR Series

High-Speed Angular Contact Thrust Ball Bearings

High rigidity thrust bearings for lathe applications.

- › Two types of contact angle: 30° (BAR), 40° (BTR)
- › Two types of ball material: Steel (S type) and Ceramic (H type)



BGR Series

Ultra High Precision Angular Contact Ball Bearings

High Performance bearings developed specifically for internal grinding or high-speed motor applications under spring preload.

- › Bore size range: $\phi 6$ –25 mm, contact angle: 15°
- › Two types of ball material: Steel (S type) and Ceramic (H and X type)
- › Non separable type
- › Universal combinations (DU and SU)



Special Series

Sealed Angular Contact Ball Bearings

Pre greased and sealed to reduce handling problems.

Suitable for maintenance of machine tool spindles.

- › Standard series super precision angular contact ball bearings
- › ROBUST series high-speed angular contact ball bearings
- › Bore size range: $\phi 30$ –100 mm in ISO series 10 and 19 (70xx and 79xx)



Robust Series Standard Series

Ultra High-Speed Single Row Cylindrical Roller Bearings

High performance cylindrical bearings designed for ultra high-speed applications, such as machining centre spindles.

- › Two types of cage material: Brass (MR)⁽¹⁾ and PEEK resin (TP)
 - › Three types of roller material: Steel, SHX and Ceramic
 - › Ultra high-speed ROBUST RXH design can be used up to 3 million $d_m n$.
- (1) MR cage is used in the standard series



Standard Series High Rigidity Series

Double Row Cylindrical Roller Bearings

Designed to deliver high rigidity in high-speed applications such as lathe spindles.

- › Two types of cage material: Brass (MB), PPS resin (TB)
- › Standard specification E44: Outer ring oil holes and groove



Special Series
For Machine Tool Applications

Angular Contact Thrust Ball Bearings for Ball Screw Support

High rigidity thrust bearings designed specifically for ball screw support applications in machine tools.

- › Contact angle: 60°
- › Can be universally matched to any required rigidity specification or life cycle
- › A pre-greased line using special grease is also available
- › A new series is available, supplied with contact seals and waterproof grease



Special Series
For Injection Molding Machines

Angular Contact Thrust Ball Bearings for Ball Screw Support

The high load capacity design delivers five times the life expectancy compared to ball screw support bearings for machine tool applications of a similar size. The number of rows can also be reduced.

- › Easier handling than tapered roller bearings or thrust spherical roller bearings as a result of non-separable configuration
- › Optimum ball bearing design results in lower rotational torque
- › Can be universally matched to any required rigidity specification or life cycle



Special Series

High Precision Angular Contact Ball Bearings

Suitable for high-speed and high precision motors.

- › Three types of cage: Ball guided polyamide cage (T1X,TYA) and inner ring guided phenolic cage (T), selection depends on the application
- › Suitable for silent or low vibration operation

Bearing Selection

Identification Markings

NSK Precision bearings carry useful information for both the designers and fitters. The box itself will indicate date codes, serial numbers, bore, outer diameter and width deviations. This information is also found on the bearing so even if the box is lost/missing, all the relevant information is still available.

Product Serial Number

Every NSK brand bearing has a unique serial number; this enables complete traceability of the product since final inspection data is stored within NSK records associated with this number.

Size Deviations

Every precision bearing is 100% inspected and the size deviations are indicated on both the box and the bearing. The outer ring contains the size deviation of the outer ring OD and the bearing width deviation respectively and the inner ring contains the size deviation of the inner ring bore. This information is also placed on the box. The example box on page

13 indicates that in this example the bearing inner ring bore is 25mm -1 microns i.e. the exact size is 24.999mm.*

The outer ring is 47mm -3 microns i.e. the exact size is 46.997mm.*

The bearing width is 12mm -57 microns i.e. the exact size is 11.943mm.*

* Bearing envelope dimensions found from the global catalogue

f and b

The 'f' refers to the front face preload step and the 'b' refers to the rear face preload step. The value of 'f' and 'b' are the absolute step in microns and is recorded on the box label rounded to the nearest micron.

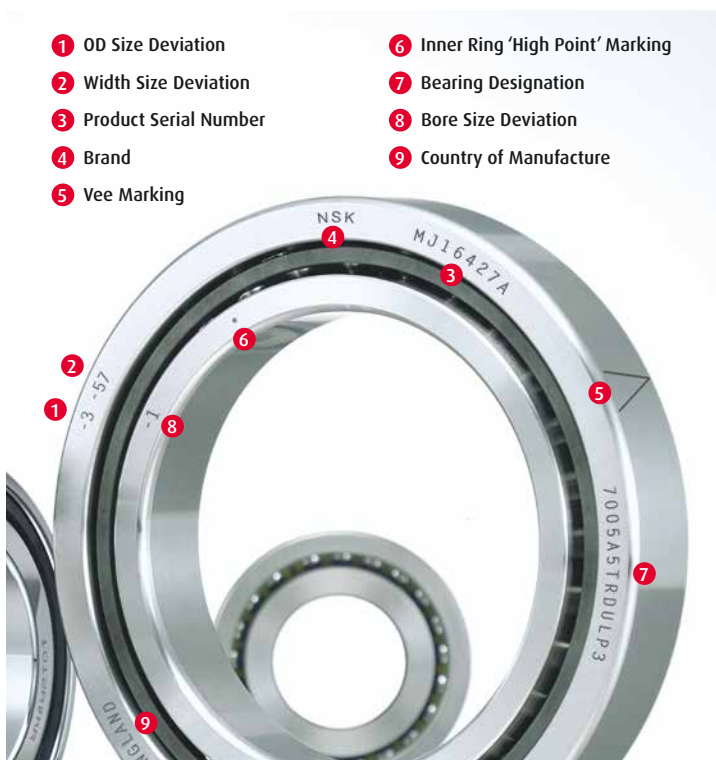

- 1 OD Size Deviation
- 2 Width Size Deviation
- 3 Product Serial Number
- 4 Brand
- 5 Vee Marking
- 6 Inner Ring 'High Point' Marking
- 7 Bearing Designation
- 8 Bore Size Deviation
- 9 Country of Manufacture

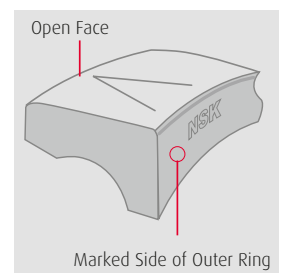
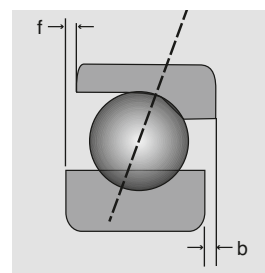

Vee Lining - Individual Bearings

A single Vee line is placed on the outer diameter of the outer ring. The positioning of the Vee serves two purposes:

1. The radial position indicates the point of maximum ring thickness, i.e. the position of maximum outer ring runout.
2. The point of the Vee indicates the open face of the bearing. This is particularly useful when using sealed bearings since the same size seal is often used on each side of the bearings making it difficult to see which is the open face.

Examples of matched sets with overall vee line:

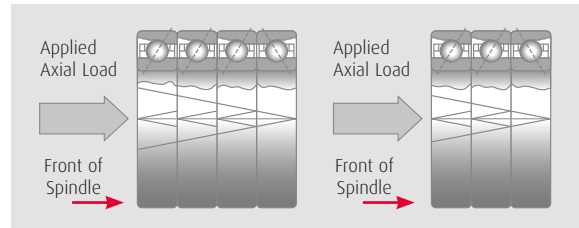
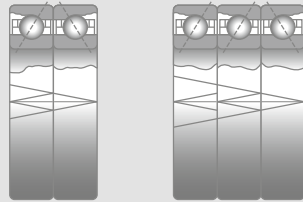

- D: -3 = Outer Ring OD
- d: -1 = Inner Ring Bore
- C: -57 = Bearing Width
- f: -1 = Front Face Preload
- b: -1 = Rear Face Preload

Vee Lining – Bearing Sets

If bearings are ordered in matched sets there will also be a vee line marked across the complete set as well as the individual vee line. Bearings used in matched sets should not be taken out of the sequence of the set. The direction of the overall vee also indicates the direction of axial loading; this is important when the bearing arrangement is non-symmetrical as shown above.

Inner Ring High Point Marking

The '0' on the face of the inner ring indicates the position of the maximum ring thickness i.e. the position of maximum ring runout. (See 6 on page 12)

How to use High Point Marking

Optimum running accuracy is achieved when the bearing is mounted so that the ring high points are directly opposite (180°) to the high points on the housing and shaft. With regard to the shaft, find the high point using a suitable DTI (Dial test indicator) and mount the bearing with the inner ring high point at 180°. With regard to fitting the outer ring into the housing, mount the outer ring vee mark 180° to the high point measured in the housing.

If the runout of the shaft is measured at 2µm, placing the inner ring as shown above can help to reduce the runout close to zero. The shaft runout is much more important than the housing runout, which can also be more difficult to measure accurately.

High Point Marking

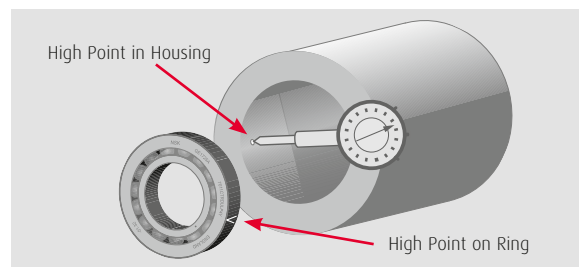
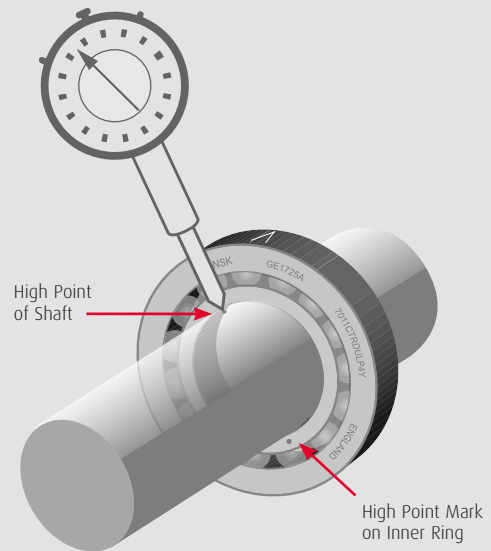

1. Useful Tip

If it is not possible to measure the shaft and housing runouts it is advisable to position the bearing high points out of line so as to avoid accidentally aligning the bearing high points with the shaft high points thereby increasing overall runout.

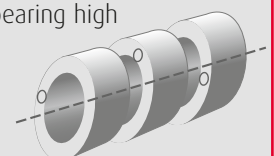

Bearing Selection

Contact Angle

A fundamental part of the angular contact bearings is the contact angle. These bearings can only take axial load in one direction unless they are used in sets (see universal sets).

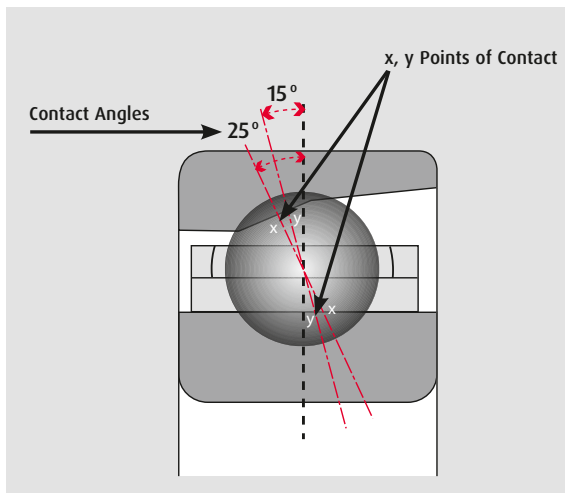
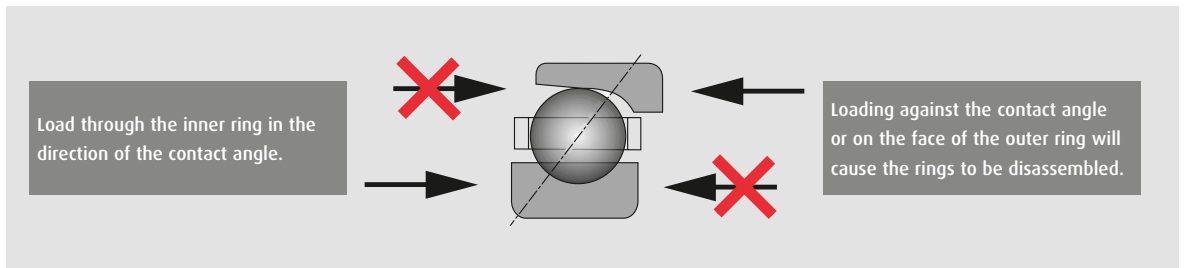

Popular Contact Angles:

Standard Precision	15°
	25°
High-Speed 'Robust'	18°
	25°
Thrust	30°
	40°
Ball Screw Support	60°

As the contact angle increases, the axial load capacity increases but the speed and life decrease. Angular contact bearings with small contact angles are more suitable for high-speeds and radial loads.

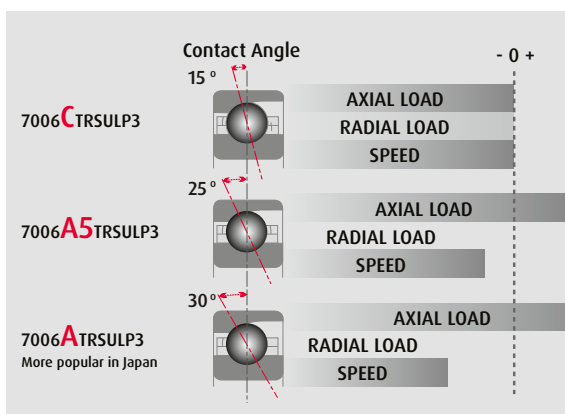

Effect of Contact Angle – Standard Designations

For high-speed products; 18° has been adopted as the lowest standard contact angle. This has been shown to be more effective at high-speeds in terms of bending stiffness compared to 15°. An 18° contact angle provides better axial stiffness than 15°, but less radial stiffness. However, as seen from the spindle diagram, bending stiffness is more important.

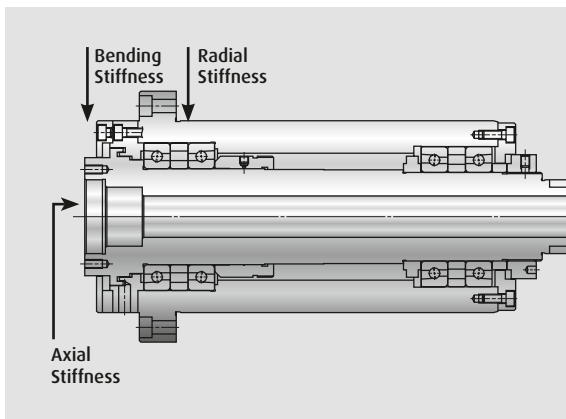
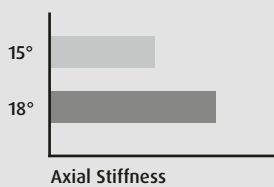

For high-speed applications using motorised spindles, the internal heat generation can be much higher than belt driven spindles; this can reduce the bearing internal clearance and sometimes cause failure at high-speed.

For these applications it is more beneficial to select a 25° contact angle because this has a greater radial internal clearance (RIC) compared to the 18° contact angle and can more easily accommodate a reduction in internal clearance due to thermal movement.

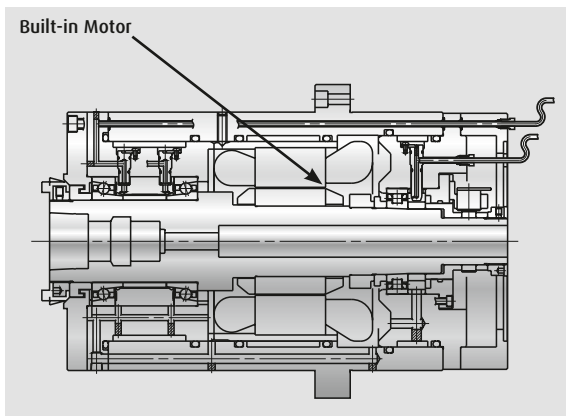

Examples of Contact Angle - High-Speed and Thrust Designations

- 25BGR10STDUEL2 = 15° Robust High-Speed Grinding Applications
- 30BNR10STDBELP = 18° Robust High-Speed
- 30BER10STDBELP3 = 25° Robust High-Speed
- 30BAR10STYNDBELP3 = 30° Robust Thrust
- 30BTR10STYNDBELP3 = 40° Robust Thrust
- 30TAC62BDFC9PN7A = 60° Ball Screw Support

Bearing Selection

Universal Sets

The term universal means that the bearings can be used in any arrangement, tandem, back to back or face to face.

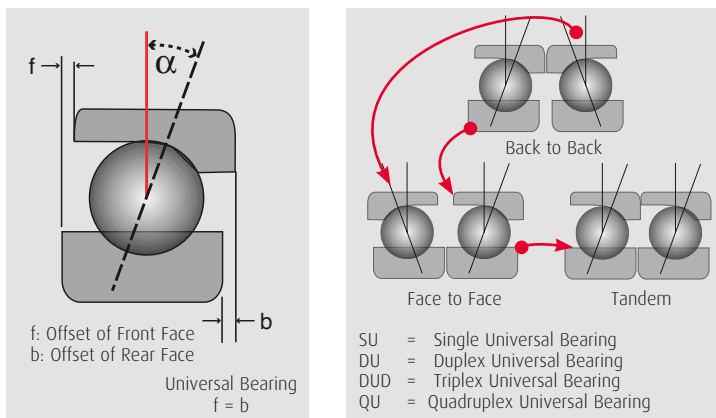

The preload step is manufactured on the rear face of the inner ring and the front face of the outer ring, both steps are exactly the same depth therefore the universal bearing can be used in any combination.

Back to Back (DB Arrangement)

The majority of machine tool applications use this type of arrangement. The preload is produced by the 'Gap' (2 x the step b) of the inner ring faces being squeezed together by a locknut on the shaft. This type of arrangement is particularly useful where moment loads are used but the accuracy of the housing must be high to reduce misalignment.

Other universal bearing combinations are shown below:

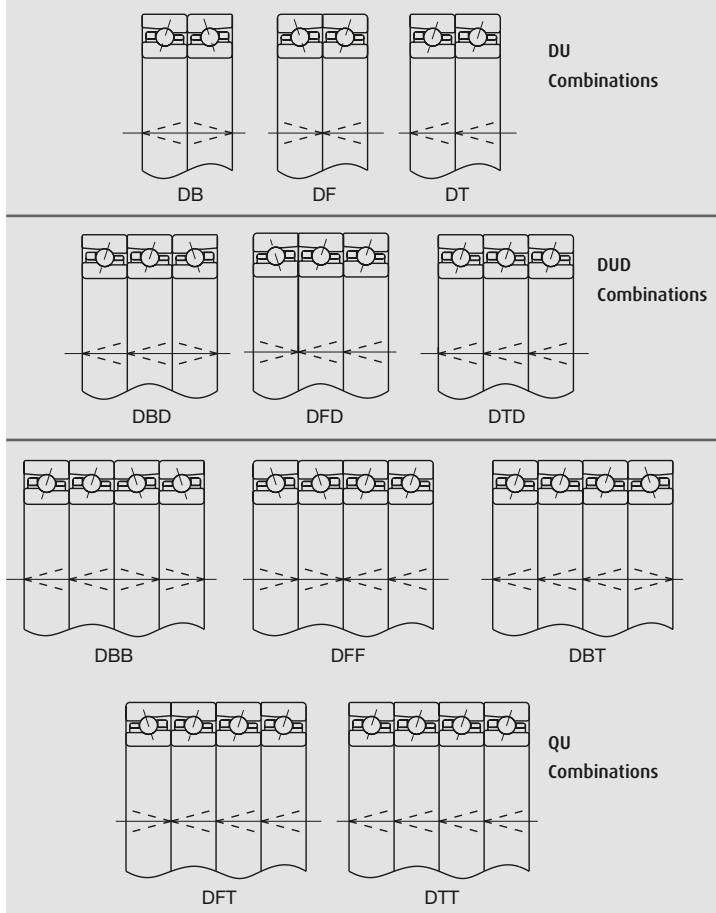

Face to Face (DF Arrangement)

This arrangement is often used for ball screw support bearing applications. The preload is produced by the 'Gap' (2 x the step f) of the outer ring faces being squeezed together by an end cap in the housing. This type of arrangement is particularly useful when good alignment cannot be guaranteed between the housings. This can be the case for Ball Screw Support Bearings since ball screws can often be 1 to 5 metres in length.

Tandem (DT Arrangement)

This arrangement needs to be used with another bearing or set of bearings in the opposing direction in order to produce a preload (see diagram). Bearings are used in these arrangements when there is a need for higher stiffness due to higher axial loads on the spindle.

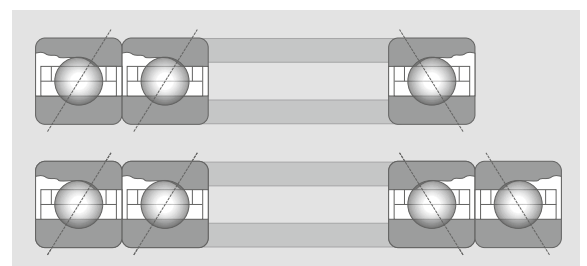

Bearing Selection

Precision Grades

Bearings are manufactured in different precision grades. The lower P number the smaller the tolerance and greater the running accuracy.

NSK	P5	P4	P3*	P2
British Standards Institution (BS 292)	EP5	EP7	-	EP9
Anti-Friction Bearing Manufacturers Association (AFBMA, Standard 20)	ABEC5	ABEC7	-	ABEC9
International Standards Organisation (ISO 492)	Class 5	Class 4	-	Class 2
DIN (Deutsche Industrie Norm)	P5	P4	-	P2

* P2 Runout, P4 External Tolerances

The table above shows the comparison of different accuracy standards. NSK use the DIN system where P2 is the greater accuracy. Additionally NSK have introduced a P3 (same external accuracies as P4 but higher internal accuracies, same as P2).

Effects of Internal Tolerances – Radial and Axial Runouts

P2 and P3 tolerance is the highest internal geometry accuracy; this results in the best radial and axial runout values.

Single Micron Grading

All NSK bearings have single micron grading for bore, OD & width. This means that the exact dimensions of every bearing can be found.

Bearing sets are matched to within 1/3rd of the overall tolerances. This is to enable optimum load sharing when fitted to the shaft and housing. P2 external tolerances tend to be approximately half of P4 and therefore are sometimes used for random matching. However there is a price penalty for P2 standard.

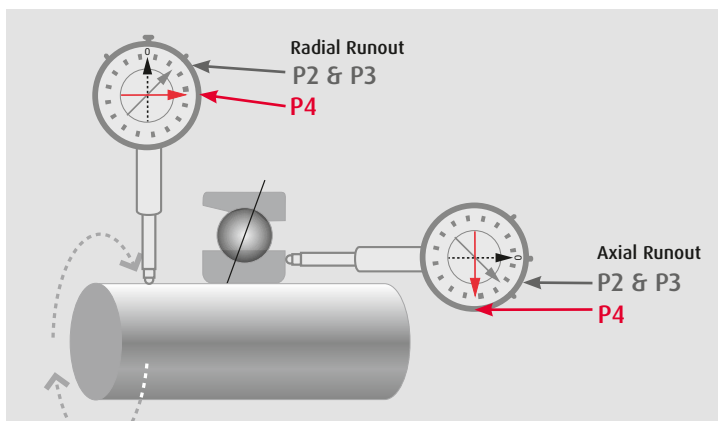
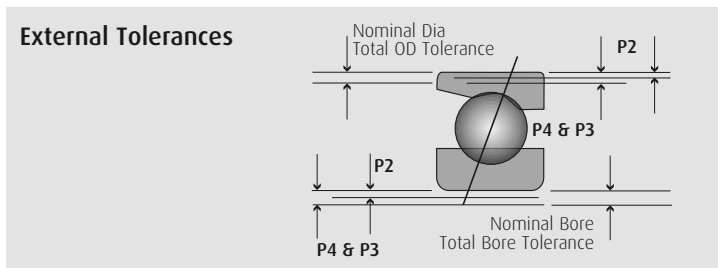

Typical Tolerances for 7014 (µm)			
	P4	P3	P2
Bore	0 to -7	0 to -7	0 to -4
OD	0 to -8	0 to -8	0 to -5
Width	0 to -150	0 to -150	0 to -150
Radial Runout	0 to 4	0 to 2.5	0 to 2.5
Axial Runout	0 to 5	0 to 2.5	0 to 2.5

Example:

The bearing on the right (7008CTYNSULP4) has nominal dimensions from catalogue of:

OD = 68mm

Deviation on bearing and box = -4µm
Therefore exact OD = 67.996mm

Bore = 40mm

Deviation on bearing and box = -4µm
Therefore exact bore = 39.996

Width = 15mm

Deviation on bearing and box = -100µm
Therefore exact width = 14.900mm



2. Useful Tip
The use of P3 Precision grades is more cost effective than P2. With single micron grading it is possible to select the correct bearings for matching into sets. Internal geometry of P3 is the same as P2.

Bearing Selection

Preload – Angular Contact Bearings

The preload between angular contact bearings is achieved by clamping a pair or multiple number of bearings together.

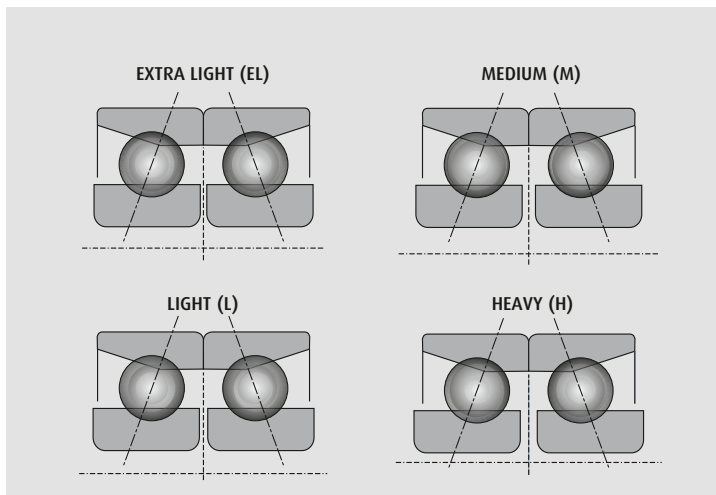

NSK has 4 standard preload arrangements as shown on left side. This allows greater flexibility in machine design and more importantly when replacing different brands.

All angular contact bearings need to operate with preload due to the following reasons:

- › Elimination of radial and axial play
- › Increased rigidity
- › Reduced runouts, increasing accuracy
- › Helps to prevent ball skid at high-speed

There are two types of preloading methods:

1) Constant Pressure (Spring Preload)

This type of preload is primarily use for grinding applications or very fast machining. The speeds quoted in the catalogue are all for this type of preload. This preload is achieved by the use of sets of coiled or weaver disc springs. In the arrangement (Fig.X), even if the relative position of the bearings change during operation the magnitude of the preload remains relatively constant.

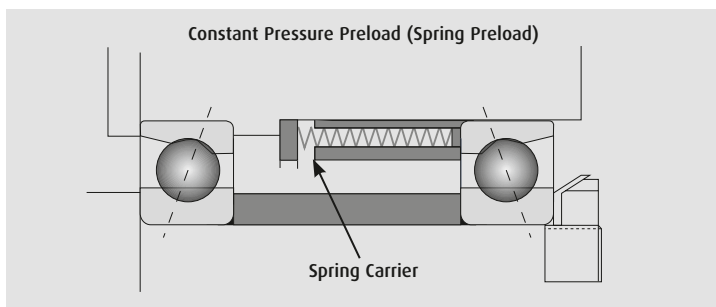

2) Position Preload (Fixed Preload)

This is the most common type of preload arrangement and can either be arranged with or without spacers. The main advantage of this type is that the stiffness (rigidity) is much higher. However, the speed quoted in the catalogue needs to be factored according to the amount of preload and number of bearings in the set. This information is given in the NSK Super Precision catalogue and printed below for reference.

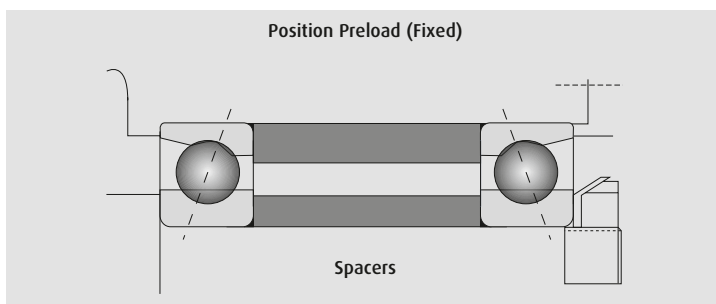

	Arrangement	EL	L	M	H
DB		0.85	0.80	0.65	0.55
DBB		0.80	0.75	0.60	0.45
DBD		0.75	0.70	0.55	0.40

Speed Factor Table

NSK has the most levels of standard preload available:

- EL = Extra light – fastest speed, less rigidity
- L = Light – slightly higher rigidity
- M = Medium – lower speed, good rigidity
- H = Heavy – highest rigidity, lowest speed

Special Preloads and Axial Clearance

Gxx is special preload (xx is the mean preload in kgf)

CPxx is special preload (xx is the mean preload gap in μm)

CAXx is a special clearance (xx is measured axial clearance in μm)

Special preloads are available on request. In some cases these are generated as Gxx where xx is the amount of preload force i.e. G5 = 5Kgf. This is mainly used for some special Ball Screw Support Bearings. Or an axial preload gap is quoted i.e. CP10 = 10 μm preload gap.

Axial Clearance

An axial clearance means that there is no initial preload. This type of arrangement is often used when application speeds are high and the bearing inner ring fit is much tighter than normal, this is to prevent a loss of fit between the inner ring and shaft due to centrifugal expansion of the inner ring. When the bearing is fitted with the tighter fit the radial expansion of the bearing due to the fit increases the amount of preload to a normal level. If an application requires a special CAXx level, it must not be substituted by a standard E, EL, M or H level preload and run at the same speed, this could cause premature seizure.

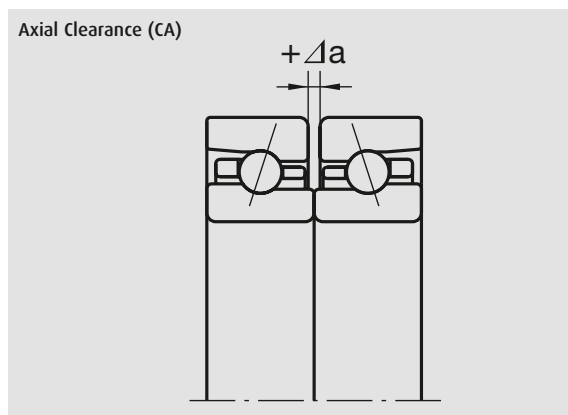

Effects of Preload on Bearing Performance

The amount of preload affects the performance of angular contact bearings. The diagrams below show the effects on rigidity, temperature, life and speed ($d_m n^*$) for a pair of 7020 with a 15° contact angle.

The graphs show that as the preload level increases, both the axial and radial rigidity (stiffness) increase, speed capability reduces and temperature increases. In order to maintain high rigidity, it is necessary to sacrifice speed. Similarly in order to achieve high-speed it is necessary to sacrifice rigidity. To run at higher than factored catalogue speed with heavy preload could lead to thermal instability and premature seizure of the bearing.

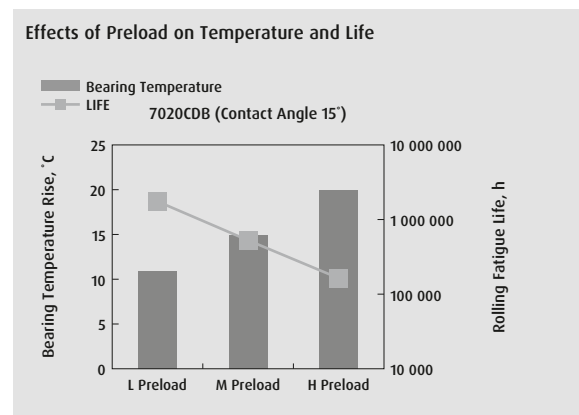
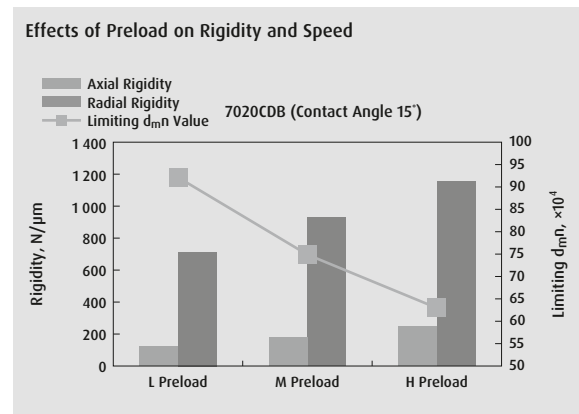

Bearing Selection

Preload – Angular Contact Bearings

Bearing Combinations

Angular contact bearings are usually used as multiple bearing sets. Two rows, three rows and four rows are the most common multiple bearing sets.

Bearings are used in multiples to increase the load carrying and stiffness capability. When the number of rows is increased, the rigidity and the load capacity become larger but the limiting speed is reduced. Depending on the arrangements, loads can be taken from either one or both directions.

The DT arrangement can only take load in one direction but since there are two bearings with the contact angle in the same direction, it has twice the axial stiffness as a single row bearing. A set of four bearings arranged symmetrically, could take loads in both directions and have twice the axial stiffness in both directions.

* $d_m n$ = the bearing mean diameter (mm) x the speed in rpm
 mean diameter = $\frac{D+d}{2}$ where D = OD and d = bore

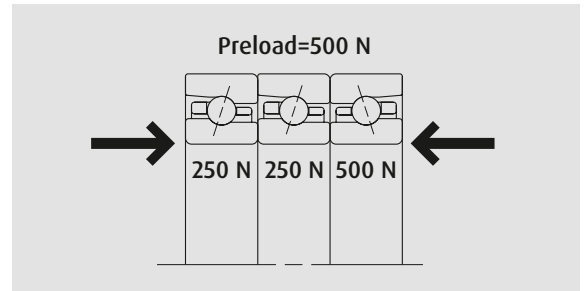

In the example of three rows, it can be seen that the internal preload is not shared evenly, this means that one bearing is taking twice the preload of the pair and will operate at a slightly higher temperature. For this reason, it can be seen from the **Speed factors table (page 18)**, that the speed capability of a set of three is less than a set of four. Load can be applied from either direction but greater load from the left side.

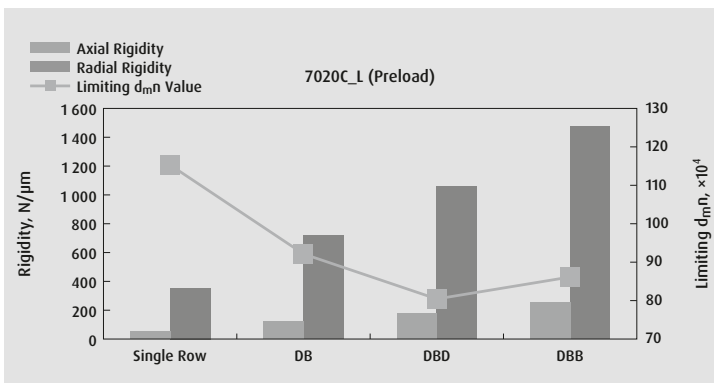

Capacities and Rigidities for Multiple Bearings

The single row capacities are shown in the NSK Super Precision catalogue for all products.

The table below shows the multiplying factors for both the dynamic (C_r) and static (C_{or}) bearing capacities:

Double row		Triplex row		Quadruplex row	
C_r	C_{or}	C_r	C_{or}	C_r	C_{or}
1.62	2	2.15	3	2.64	4

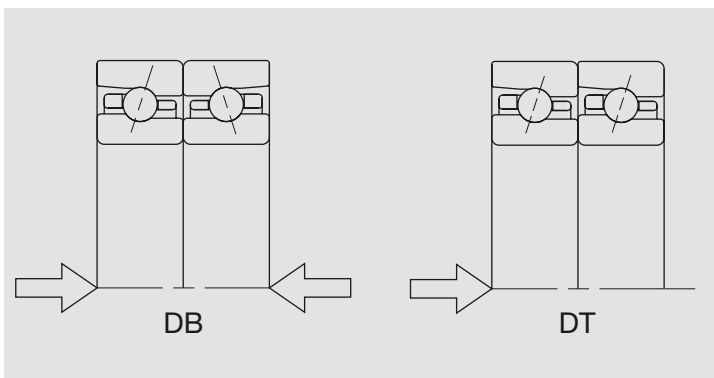

The NSK Super Precision catalogue also states the preload and axial rigidity for pairs of all products. This information is useful when testing a newly assembled spindle. The radial rigidity can be simply calculated by using the factors in the table below i.e. for Light preload and 15° contact angle, multiply axial stiffness given in the catalogue by 6 to get the radial stiffness.

Calculation of Radial Rigidity

To find the preload and axial rigidity for 3 and 4 rows of bearings, multiply the values given in the catalogue by the factors in the table right.

Stiffness and Preload for Sets

Likewise multiply the value of radial stiffness found in the table above by the factor in the table to the right. To derive the radial stiffness for three or four bearings in a set, i.e. if the catalogue axial rigidity was 200N/μm for 15°, Light preload; the radial rigidity for a set of 3 would be $200 \times 6 \times 1.54 = 1848 \text{N}/\mu\text{m}$.

	EL	L	M	H
15°	6.5	6.0	5.0	4.5
18°	4.5			
25°	2.0			
30°	1.4			
40°	0.7			

	DBD	DBB
Preload factor	1.36	2
Axial rigidity	1.48	2
Radial rigidity	1.54	2

3. Useful Tip

In an emergency situation, if the correct preloaded bearing is not available and spacers are used, it is possible to use a different preload set of bearings and adjust the spacers to compensate. The NSK Super Precision catalogue shows the axial clearances for each set of angular contact bearings.

Example:

Preload and rigidity									
Preload and Rigidity (DB and DF Arrangement)									
High Precision Angular Contact Ball Bearings (Standard series)									
79 series, C angle									
Nominal contact angle 15° Steel ball and Ceramic ball									
Bore Number	Bearing Bore (mm)	Preload (N)	EL	Preload (N)	L	Preload (N)	M	Preload (N)	H
05	10	7	(5)	10	(2)	14	29	(-1)	19
01	12	8.6	(4)	12	(1)	16	39	(-3)	24
02	15	12	(3)	14	(0)	20	49	(-4)	26
03	17	12	(3)	15	(0)	20	59	(-5)	30
04	20	19	(1)	19	(-3)	26	78	(-8)	35
05	25	19	(1)	21	(-2)	28	100	(-9)	41
06	30	24	(0)	25	(-3)	33	100	(-9)	45
07	35	34	(2)	29	(-2)	39	100	(-9)	45
08	40	39	(1)	32	(-3)	42	200	(-13)	63
09	45	50	(0)	37	(-5)	50	200	(-12)	66
10	50	50	(0)	39	(-4)	51	250	(-14)	78
11	55	60	(-1)	45	(-6)	58	290	(-15)	90
12	60	60	(-1)	46	(-5)	60	290	(-14)	93
13	65	75	(-2)	53	(-7)	71	340	(-16)	104

The values in () show measured axial clearance

If a 7906CTRDUHP4 is required but only 7906CTRDUMP4 is available, the spacer can be machined to compensate for the different preload. From the table above for 30mm bore the Heavy preload axial clearance is 16μm and the Medium preload axial clearance is 9μm. Therefore to change from Medium preload to Heavy preload it is necessary to change the spacer length by the difference i.e. $16\mu\text{m} - 9\mu\text{m} = 7\mu\text{m}$. In this case because we are increasing the preload we need to reduce the inner ring spacer by 7μm and leave the outer spacer untouched.

This information can be found on global catalogue pages 156 to 166 for your reference.

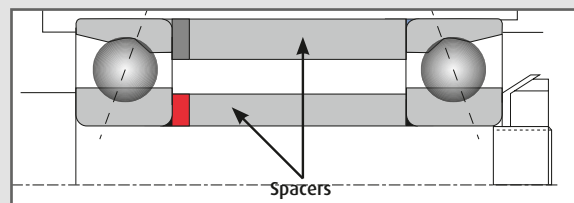

Rule:

- To increase preload: reduce inner ring spacer
- To reduce preload: reduce outer ring spacer

Remember: this is for emergency situations only, if the preload is changed in this way care should be taken to document the changes so that if the bearings are replaced in the future the correct preload is selected to allow for the spacer changes.

Bearing Selection

Preload – Cylindrical Roller Bearings

In order for machine tool spindles to have high running accuracy and rigidity, cylindrical roller bearings should be operated with either controlled radial clearances or preload.

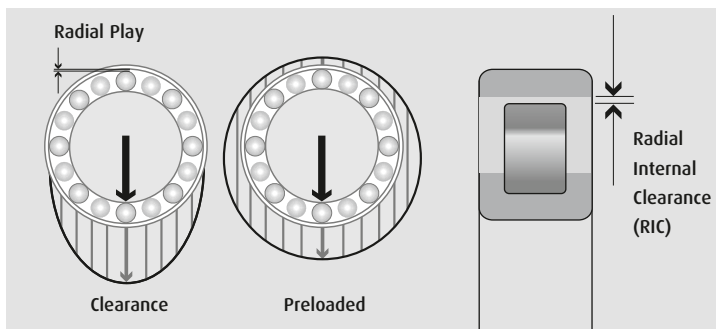

Roller bearings are supplied with standard RIC (Radial Internal Clearance) values:

CC1 for cylindrical bores, **CC0** for tapered bores

CC9 is a reduced clearance for tapered bores when used with light fits (non standard). This should not be used in high-speed since the fit may not be adequate.

The clearance/preload of a tapered bore bearing can easily be changed in-situ by pushing the bearing up the 1:12 taper. The dial gauge can only indicate the clearance situation. To apply a radial preload it is necessary to use a special NSK gauge or follow the technique outlined in Mounting Section.

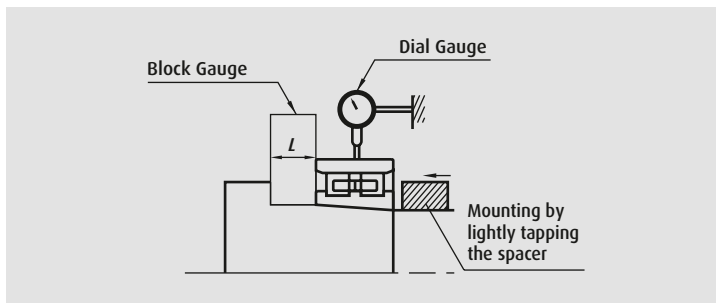

Bearing Rigidity

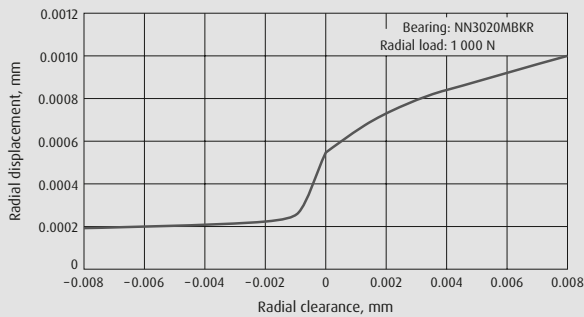

Life Ratio

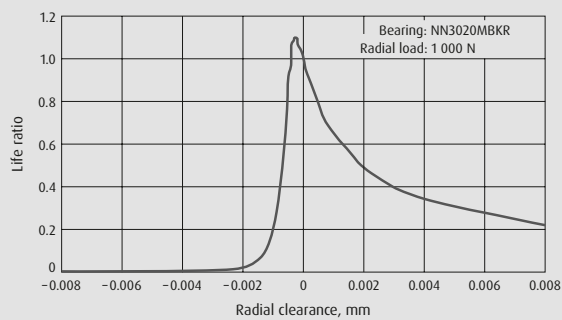

Reasons for Using Preloaded Conditions

If the cylindrical bearing is run with a clearance, only a small proportion of the rollers will carry the radial load. This proportion increases as the clearance is reduced to zero. However when Preloaded, it can be seen that all the rollers are under load, this helps to increase life and also increases the bearing radial stiffness.

Amount of Preload

Tests have shown that the optimum amount of preload is between zero to $3\mu\text{m}$ tight for the front roller bearing and a slight clearance (-2 to $-5\mu\text{m}$) for the rear roller bearing. The graph below shows the bearing rigidity for clearance (right hand side) and preload (left hand side).

The life relationship between clearance and preload can be seen below. The values will vary for different sizes of bearings but will be the same trend.

Thrust angular contact bearing.



Front: Double row tapered bore cylindrical roller bearing.
Usually preloaded.

Rear: Double row tapered bore cylindrical roller bearing.
Usually slight clearance.

Bearing Selection

Bearing Matching

Bearing Matching Chart
(When bearings are ordered in defined sets i.e.)

DU

DUD

QU

The adjacent bearings in the set are selected in the factory so that the maximum difference in bore or OD tolerance is within one third of the overall size tolerance. This is to ensure that once the bearings are fitted to the shaft and in the housing that the fits from bearing to bearing are fairly similar and thereby the load distribution within the bearing set is shared equally.

All NSK bearings are 100% inspected and the bore and OD size deviation in microns is marked on both the bearing and the box. For designers this is a useful feature since it allows the shaft and housing to be made to suit the bearings. For the example shown above the bore of the inner ring has a deviation from nominal of -1 micron. If this inner ring was nominally 70mm diameter then the exact bore diameter will be 69.999mm.

For repair shops this information is even more valuable since it allows greater flexibility when ordering bearings and enables different combination arrangements to suit different spindle designs.

NSK provide a handy sliding chart that enables bearings to be easily matched into appropriate sets. First select the series i.e. 73xx, 72xx, 70xx or 79xx and then the precision grade, P2, P3 or P4 and slide the chart to the appropriate bearing size to find the allowable difference in inner ring size deviation for each bearing in the set and independently for the outer ring OD for each bearing in the set.

The examples on left show that for a large bearing a greater tolerance between bearings in each set can be used. In general most bearings can be matched within 2 microns to give optimum load sharing.

Bore & OD matching chart

72**	72
Permissible difference of OD in a matched set (µm)	P2
	P3
	P4
Permissible difference of bore in a matched set (µm)	P2
	P3
	P4

Universal bearing matching
Super Precision ball bearings are made in accordance with the International Standards Organisation's dimension plans. All bearings in a set must be within permissible bore & OD deviation from nominal dimensions. This improves load sharing when bearings are mounted closely.

73**	73
Permissible difference of OD in a matched set (µm)	P2
	P3
	P4
Permissible difference of bore in a matched set (µm)	P2
	P3
	P4

The size difference of the OD and bore of sets of bearings is generally less than 1/3 of the size deviation. This chart can be used to identify the permissible difference between OD's and bores in a set of bearings for precision grades for P2, P3 and P4.

NSK Super Precision Ball Bearings

79**	79
Permissible difference of OD in a matched set (µm)	P2
	P3
	P4
Permissible difference of bore in a matched set (µm)	P2
	P3
	P4

The bearings are graded with the deviation in microns from the nominal size.

70**	70
Permissible difference of OD in a matched set (µm)	P2
	P3
	P4
Permissible difference of bore in a matched set (µm)	P2
	P3
	P4

Some Possible Spindle Arrangements

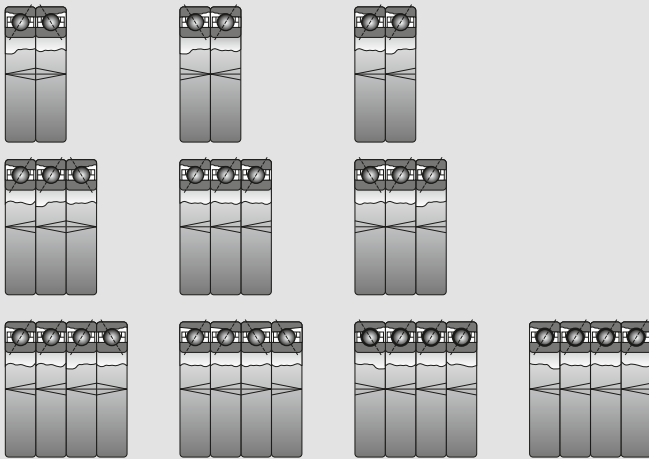

It can be seen that it would be very expensive to stock every combination of different spindle arrangements. With the use of the single micron grading the repairer only need to stock a suitable number of either SU's or DU's and the correct number of bearings can be assembled together by the repairer as long as the bore and OD deviations are within one third of the overall bearing tolerance.

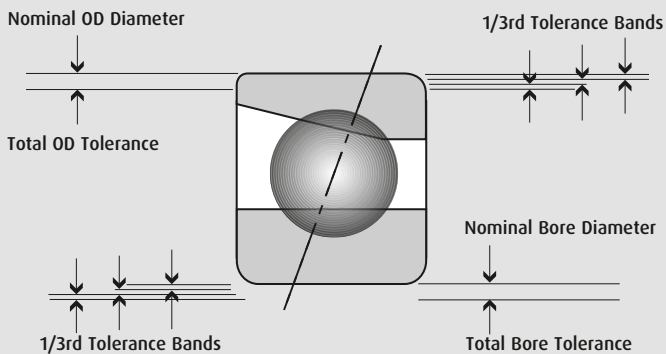

Pre-Mounting Cleanliness and Washing

In order to obtain the optimum performance from spindle bearings it is necessary to ensure that the environment in which they are fitted is of the best possible cleanliness condition.

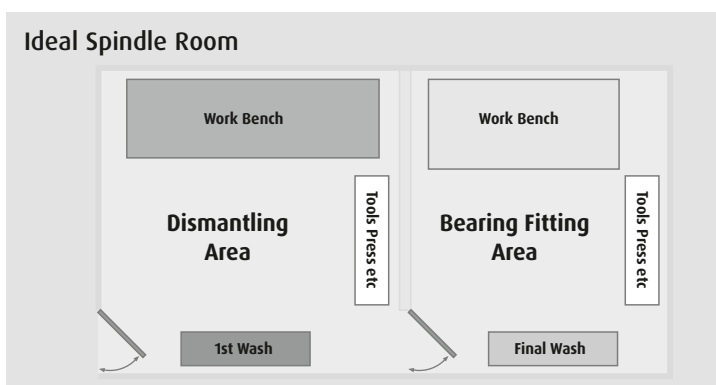

The washing solutions for bearings should be finely filtered to at least 5µm and any air supply needs to be filtered with appropriate de-humidifiers to prevent water contamination. Tools should be clean at all times when assembling bearings and free of burrs that could cause damage to the bearings whilst fitting.

Contamination

Precision bearings are made to very exacting standards with dimensional and geometrical accuracies measured in microns and sub-microns respectively. It is important to guard against contaminates, hard or soft, entering the bearing during the fitting process.

The diagram on left side shows the relative size of various contaminates, all of which could cause problems if entering the bearing. Metallic debris would usually be much larger than the examples shown here. Another useful way to prevent contamination during fitting is to use sealed bearings. More information on this product range can be found in this catalogue (see page 11).

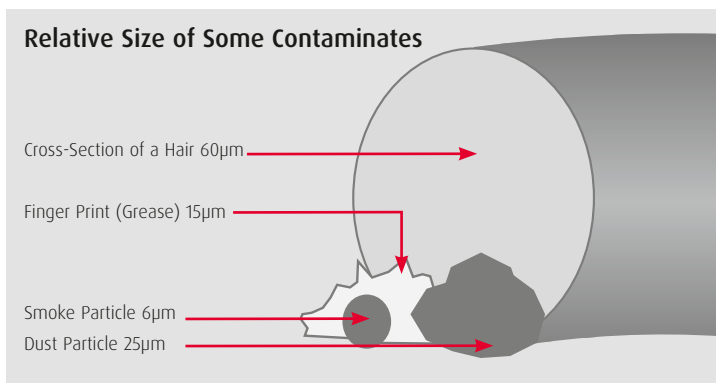

Ideally dismantling and assembling of spindles should be separated to ensure no cross contamination. It is not always practical for some organisations to use the ideal model above, below is a list of essential improvements, good improvements and ideal improvements. Depending upon the organisations current situation the appropriate areas for improvement can be selected:

1 – Essential

- › Separate wash tanks, Separate work bench

2 – Good

- › Separate tools

3 – Ideal

- › Separate room (restricted personnel)

Handling Bearings

Avoid heavy shocks during handling. Shock loads can scratch or damage a bearing, possibly resulting in failure. An excessively strong impact may cause brinelling, breakage or cracks.

Corrosion Prevention

Handling bearings with bare hands can corrode the bearing surfaces because of the acidic moisture or other contaminates on the hands. When handling bearings it is best to wear lint free protective gloves.



Global Packaging

When NSK bearings are supplied in the new global packaging specification, there is no need to pre-wash the bearings before mounting. **(A)**

The Global packaging has the following features:

- › Low viscosity preservative oil that is chemically compatible with common machine tool bearing greases
- › VPI (Vapour Phase Inhibitor) impregnated into the nylon polyethylene laminated bag. This gives extra corrosion protection
- › Bearing vacuum packed and heat-sealed for added protection from the outside environment

This same packaging method is used for factory-greased bearings and all sealed bearings. So there is no need to pre-clean the bearings before mounting.

Cases for Cleaning Bearings

In certain circumstances it is necessary to clean bearings before mounting; this will be the case when:

- › Packaging does not conform to the standard described above
- › Ultra-high-speeds are required such as when using some 'Robust' bearings
- › Roller bearings - particularly need cleaning in order to remove oil film before measuring and setting the correct radial internal clearance at mounting

Method of Cleaning

1. Use Kerosene or light oil to clean the bearings.
2. Use separate tanks for first cleaning and final cleaning. Each tank should be equipped with a wire rack to prevent direct contact of the bearing with any contamination that may have settled at the bottom.
3. In the first cleaning tank **(B)**, avoid rotating the bearings. After cleaning the outside surfaces with a soft brush, move the bearings to the final cleaning tank.
4. In the final cleaning tank **(C)**, rotate the bearing by hand very gently. Make sure that the cleaning fluid in the final cleaning tank is kept clean.
5. Remove excess cleaning fluid from the bearing after cleaning. Allow the bearing to completely dry before applying grease or oil using a lint free cloth.

Bearings using ordinary grease lubrication need to be packed with grease before leaving open to the environment since the metal surfaces will be vulnerable to corrosion at this stage. **(D)**

Oil lubricated bearings should be mounted on the machine tool taking care not to rotate the bearing. Prior to mounting it is recommended to lightly coat the inner and outer surfaces with a clean light film of oil to assist mounting. **(E)**

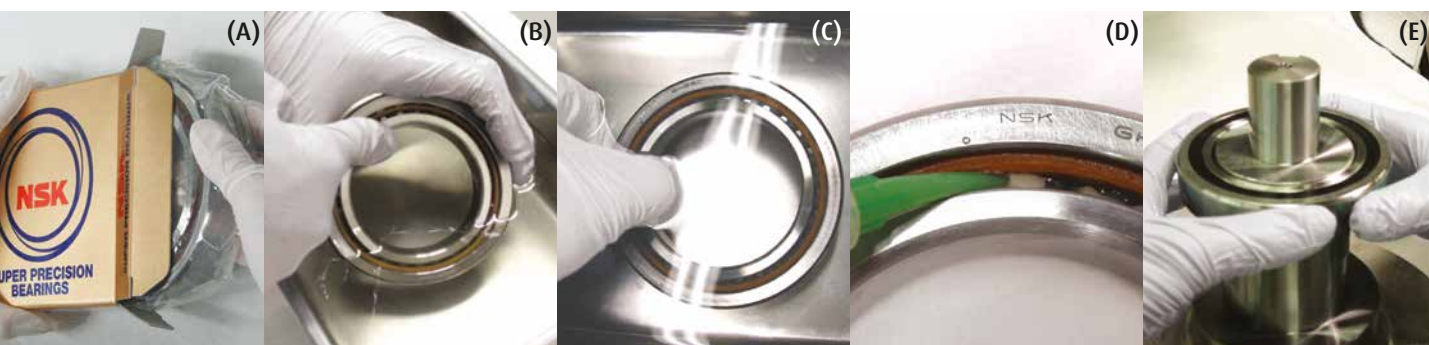

Note: Once bearings are washed and cleaned, avoid rotation before lubricating since this can cause damage to the rolling elements and raceways. Additional information can be found on the greasing process on page 28.

Pre-Mounting Greasing Process

The greasing process is very important to the successful performance of the bearing. Extra care needs to be taken to ensure no contamination enters the bearing at this point.

The following is a good practice guide to the greasing of bearings:

- › Take care to ensure that grease tin lids are always replaced after use
- › Keep grease tins/tubes in a clean separate store at a stable temperature
- › Label tins/tubes with dates, do not use over three years old
- › Use clean spatulas for dispensing grease, ideally use plastic syringes



Quantity and Position of Grease in Bearing

The ideal quantity of grease for a spindle bearing is: 15% of the bearing free volume for angular contact bearings and 10% of the free volume for cylindrical roller bearings. The exact quantities in cubic centimetres for the complete range of NSK bearings can be found in the table on page 29.

For angular contact bearings with ball guided TYN type cage: pack the grease evenly between the balls from both sides of the bearings.

For outer ring guided phenolic type cages pack half of the quantity between the inner ring OD and cage bore on the rear side of the bearing and the remaining half between the cage OD and the counter bore of the front face of the bearings. For either type cage, rotate the bearing by hand to spread the grease evenly on the surfaces of the raceways, balls and cage. **(A)**

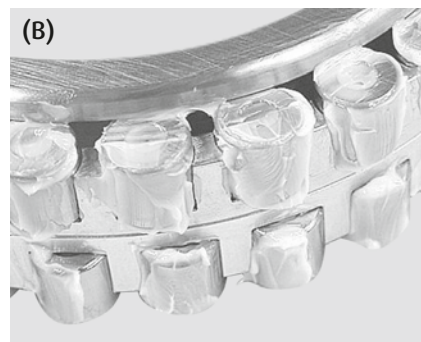
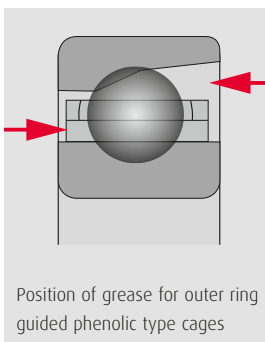

For cylindrical roller bearings:

1. Coat about 80% of the grease quantity around the roller rolling surfaces taking care not to put too much grease on the cage bore. (This can cause high temperatures during start up.)
2. Smooth a thin coat of grease over the rollers including the roller ends, roller cage contact points and along the face edges of each cage pocket.
3. Use the remaining 20% of grease to apply a thin film to the raceway surface of the outer ring. **(B)**

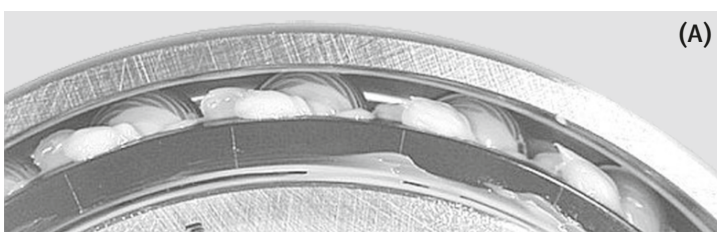

4. Useful Tip

Use a syringe to apply the correct quantity of grease in the correct position.



The Recommendable Grease Quantities for High-speed Spindle Bearings

The greasing process is very important to the successful performance of the bearing. Extra care needs to be taken to ensure no contamination enters the bearing.

Unit: cc/brg

Bore number	Bore diameter (mm)	Angular contact ball bearings: 15% of internal free space				Ball screw support bearings 50%	Cylindrical roller bearings: 10% of internal free space			
		BNR19, BGR19 BER19, 79XX X-quantity	BGR10 70XX X-quantity	BGR02 72XX X-quantity	BNR10, BAR10 BER10, BTR10 X-quantity	TAC S-quantity	NN49 X-quantity	NN39 X-quantity	NN30 X-quantity	N10 X-quantity
5	5	-	-	0.03	-	-	-	-	-	-
6	6	-	0.04	0.07	-	-	-	-	-	-
7	7	-	0.07	-	-	-	-	-	-	-
8	8	-	0.12	0.10	-	-	-	-	-	-
00	10	0.06	0.13	0.16	-	-	-	-	-	-
01	12	0.06	0.14	0.23	-	-	-	-	-	-
02	15	0.11	0.18	0.29	-	2.20	-	-	-	-
03	17	0.13	0.24	0.41	-	2.20	-	-	-	-
04	20	0.23	0.44	0.68	-	2.20	-	-	-	-
05	25	0.27	0.52	0.85	-	3.00	-	-	0.4	-
06	30	0.31	0.69	1.20	0.58	3.20	-	-	0.6	0.4
07	35	0.48	0.98	1.70	0.78	3.80	-	-	0.8	0.6
08	40	0.75	1.20	2.10	0.92	3.90/8.80*	-	-	1.0	0.7
09	45	0.83	1.50	2.60	1.20	4.20/9.70**	-	-	1.3	1.0
10	50	0.91	1.60	3.00	1.20	10.20	-	-	1.4	1.1
11	55	1.10	2.40	3.90	1.70	10.20/12.00***	-	-	2.0	1.5
12	60	1.20	2.60	4.80	1.80	12.00	-	-	2.1	1.6
13	65	1.30	2.60	5.70	1.90	-	-	-	2.2	1.6
14	70	2.10	3.60	6.50	2.80	-	-	-	3.2	2.4
15	75	2.30	3.60	7.00	2.90	-	-	-	3.5	2.5
16	80	2.40	5.10	8.70	3.80	-	-	-	4.7	3.5
17	85	3.50	5.30	11.00	4.00	-	-	-	4.9	3.7
18	90	3.60	6.60	13.00	5.50	-	-	-	6.5	4.5
19	95	3.60	6.80	16.00	5.70	-	-	-	6.6	4.7
20	100	4.90	7.20	19.00	6.10	-	5.4	4.5	6.8	4.9
21	105	5.10	9.00	23.00	7.60	-	5.6	4.6	9.3	5.9
22	110	5.20	12.00	27.00	9.10	-	5.7	4.8	11.0	7.5
24	120	7.90	12.00	31.00	9.80	-	8.4	6.5	12.5	8.1
26	130	9.00	18.00	34.00	15.00	-	11.0	8.5	18.0	12.4
28	140	9.90	20.00	42.00	17.00	-	12.0	9.3	20.0	12.9
30	150	14.00	25.00	53.00	22.00	-	24.0	14.0	23.0	-
32	160	16.00	34.00	-	26.00	-	20.0	15.0	29.0	-
34	170	14.00	42.00	-	33.00	-	21.0	15.0	38.0	-
36	180	22.00	51.00	-	46.00	-	28.0	23.0	51.0	-
38	190	27.00	47.00	-	50.00	-	30.0	24.0	54.0	-
40	200	39.00	76.00	-	61.00	-	44.0	35.0	69.0	-
44	220	42.00	-	-	-	-	-	37.0	-	-
48	240	41.00	-	-	-	-	-	40.0	-	-
52	260	77.00	-	-	-	-	-	70.0	-	-
56	280	80.00	-	-	-	-	-	75.0	-	-

Note: Do not operate bearings at full spindle speed when bearings are first installed. It is necessary to run the grease in, see page 28. The grease quantity of "xxTAC20(29)X(D)" should be the same as the double row cylindrical roller bearings, which is assembled with this bearing together.

* 40TAC72 and 40TAC90
** 45TAC75 and 45TAC100
*** 55TAC100 and 55TAC120

Pre-Mounting Component Checks

Some machine fitting can be quite complicated and take in the region of a full shift to complete. In such cases it is particularly important to check all components during the fitting process, this can eliminate unnecessary problems at the end of the process when the machine is commissioned.

The following guidelines will be useful:

- › Both shaft and housings should be checked for flaws or burrs
- › The dimensions of the shaft outer diameter and housing bores should be checked for correct size and fit. (Recommended fits for shafts and housings are given in the Global catalogue). Generally an interference fit is used on the shaft provided the application is inner ring rotating, and a clearance fit is used in the housing
- › Be careful to check the components in a number of positions to check for taper and shape as well as size (figure A shows a typical method for the shaft and figure B shows the typical method for the housing)
- › When taking any measurements it is important to ensure that the components are in a thermally stable state

Runouts Checks

Shaft radial and axial runouts should be checked to ensure that the bearing has the best possible seating accuracy. Ideally the shaft should be measured between accurate centres, however, if this is not possible use a surface plate as shown in figure C. Typical target values will depend upon the application, in general a target of 3 to 5 microns would be desirable.

Obtaining runouts of the housing is a little more difficult and although not as important as the shaft can be useful in eliminating future errors. Figure D shows a typical set up for obtaining the runout for the housing and cover shoulders. Typical target values will depend upon the application, in general a target of 3 to 5 microns would be desirable.

Spacers

Inner ring and outer ring spacers for spindle bearings should be identical in length. (Any difference will affect the preload). Ideally they should be machined together to the correct width. Parallelism errors should not exceed 3microns. (Values greater than this level can cause enough misalignment to cause bearing inaccuracies and possible noise).

5. Useful Tip

Try to ensure that all components to be measured are left in the assembly room for 24 hours before measuring. This is to allow the parts to equalise to the room and tool temperature.

Fig. A: Shaft Measurements

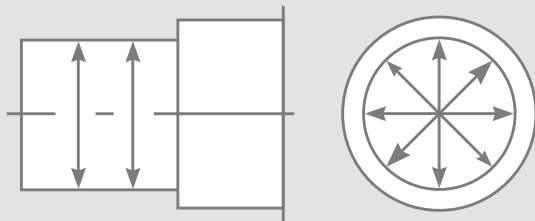

Fig. B: Housing Measurements

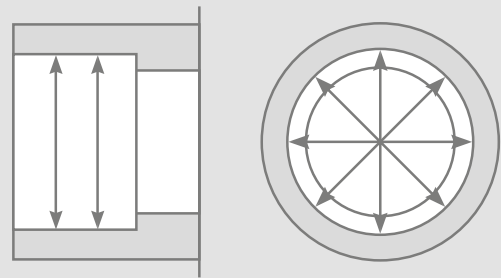

Fig. C: Runout of Shaft Shoulder

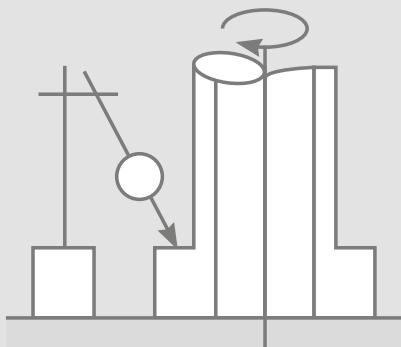
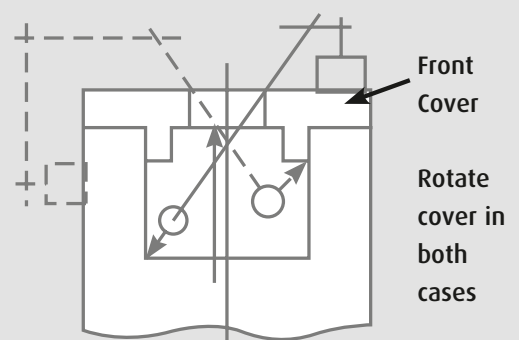

Fig. D: Runout of Housing and Cover Shoulder



Mounting Fitting Bearings to Shaft

There are two main methods of fitting bearings to a shaft are (i.) Press fit, (ii.) Shrink fit.

Press Fit

Press fits tend to be used for smaller bearings typically less than 30mm bore. It is usual to lightly oil the mating parts in order to reduce the force required for fitting. When fitting the inner ring care should be taken to ensure the press force is directed through the inner ring. In the diagram shown, a hole can be seen in the pressing piece to allow air to escape.

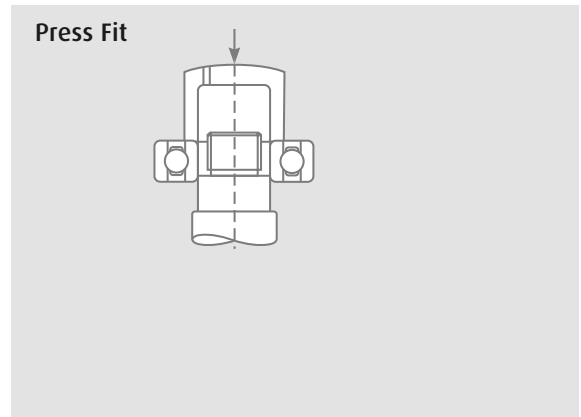

Cylindrical Roller Bearings

When the bearing is separable, the inner and outer rings can be mounted on the shaft and into the housing as separate units. Care should be taken when assembling them both together to ensure correct alignment so as to avoid scratches on the contact surfaces.

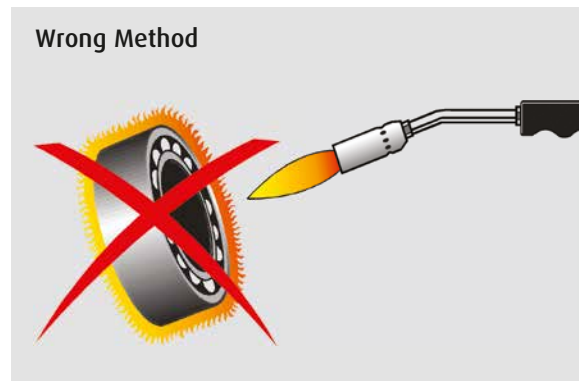

Expansion Chart

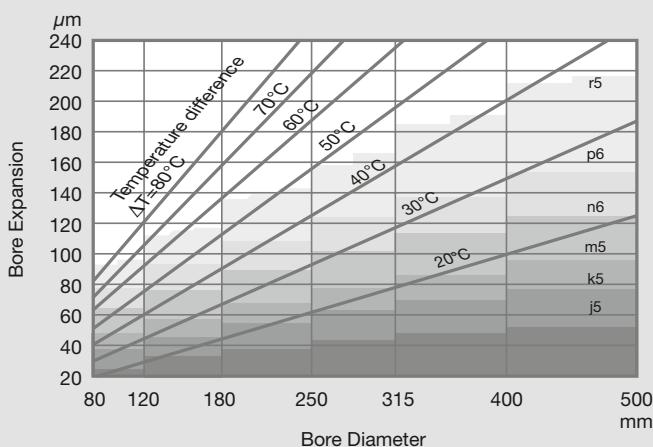

6. Useful Tip

A hot air gun can be very useful for directing heat at the inner ring only (especially for large bearings).

This method can also be used to heat a housing before inserting the shaft/bearing assembly.





Shrink Fit

This is used on larger bearings and requires heating the inner ring to expand the bore and allow fitting to the shaft with minimal effort. Care should be taken not to overheat the bearing and ideally only the inner ring needs to expand. A maximum of 120° should be applied to the bearing. For a bore diameter of 80mm, heating the inner ring to 40°C above the outer ring will expand it by 40µm. (See Expansion Chart).

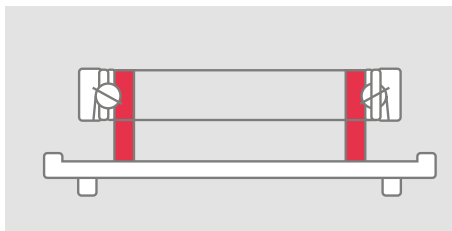

Hotplate Method

It is recommended that a steel ring is used between the hot plate and the bearing inner ring in order to conduct the heat to the inner ring and avoid heating balls, cage, outer ring and possibly lubricant.



Induction Heater Method

An induction heater is a very convenient method of heating the inner ring and the temperature can be controlled thereby preventing overheating of the bearing.

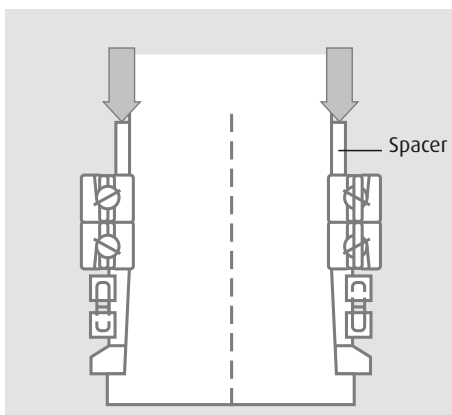

Process

Heat the bearings to required temperature plus 20° to 30° to allow for cooling from heating device to spindle. After fitting each bearing ensure that an axial pressure is applied while the bearing is cooling down. (As the bearing cools it will shrink in both axial and radial directions therefore without additional pressure the bearing may not be seated correctly). Allow cooling to room temperature +5°C before fitting the next bearing.

Mounting

Locknut Torque/Spindle Runout Checks

Locknut Torque

It is important to apply the correct locknut torque or clamping force to enable the preload gap to be closed and to prevent loosening during operation. It is also important not to use excessive force as this can distort the bearing raceways and cause loss of accuracy and possible failure; also if spacers are used between the bearings, excessive axial force could squeeze the inner spacer shorter than the outer spacer and this would increase the preload.

Spindle Checks

It is beneficial to check the spindle at each stage of the assembly process. After fitting the front bearings and clamping the locknut check spindle radial runout as shown. A target runout value of less than $2\mu\text{m}$ is recommended, however if application speeds are low, values up to $5\mu\text{m}$ are acceptable. Tapping gently on the outer ring end face can help to adjust the runout.

Using the end cover and a steel ring to support the spindle on the outer ring face, the spindle can be rotated and a runout reference taken on the shaft. This should be targeted to below $5\mu\text{m}$.

Inaccuracies in the locknut can cause the shaft and bearing to bend when tightened. The tip on page 35 shows one method to reduce this effect.

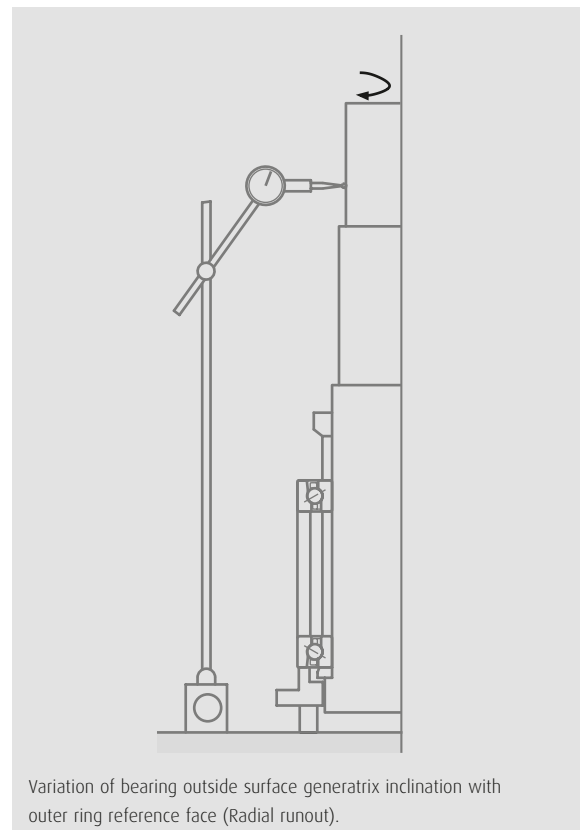
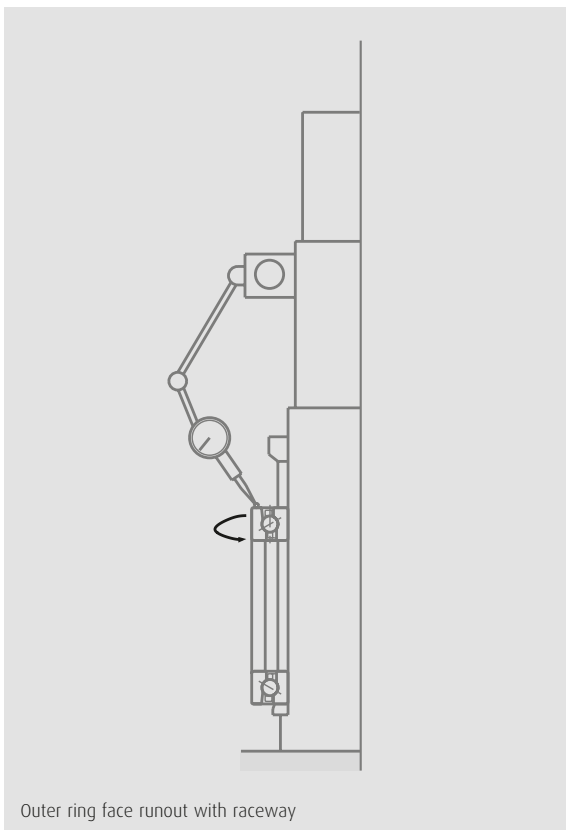

The table below shows both the axial force (useful if using a hydraulic locknut) and torque for standard locknuts.

Nominal bearing bore (mm)	Locknut tightening force (N)	Locknut tightening torque reference (N-m)
20		17
25	4,900	21
30		25
35		57
40	9,800	64
45		72
50		80
55		132
60		142
65	14,700	153
70		166
75		176
80		251
85		267
90		281
95		296
100	19,600	311
105		327
110		343
120		371
130		403
140		649
150		695
160		745
170	29,400	796
180		841
190		886
200		932
220		-
240		-
260	39,200	-
280		-
300		-

7. Useful Tip

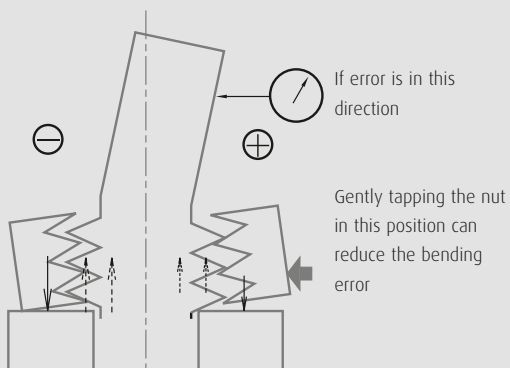

Mounting

Locknut Torque/Spindle Runout Checks

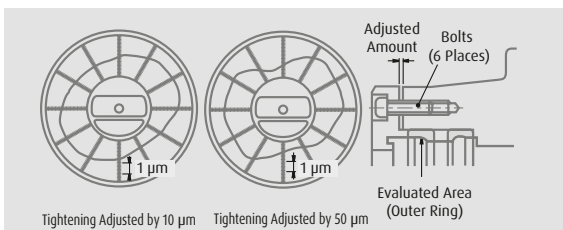
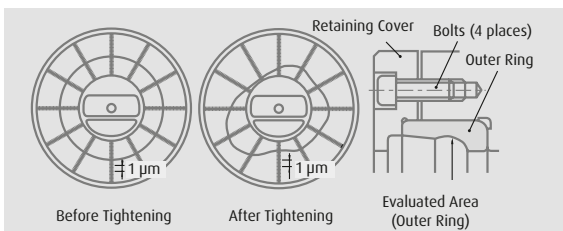
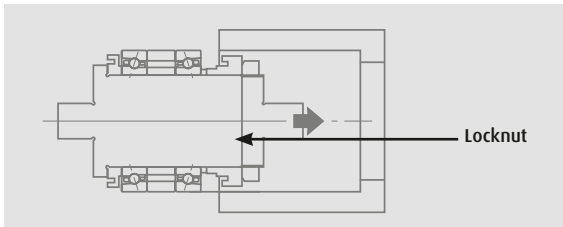

Assembly into Housing

Care should be taken when assembling bearings into the housing. Usually a clearance fit is used but if alignment is not true it could be possible to damage or dismantle a bearing. Heating the housing using an air gun as described in the Tip section helps to increase the clearance and avoid this problem.

Back to Back Arrangement

1. Assemble bearing
2. Tighten locknut
3. Insert as shown into housing

Face to Face Arrangement

1. Press bearings into housing.
2. Secure retaining cover for preloading.
3. Insert shaft into inner ring and tighten bearing locknut.

Retaining Cover Tightening

The bearing rings can become deformed if the retaining cover is not secured correctly.

The example depicted on the left shows the effect of uneven tightening of the retaining cover; in this case only four bolts are used and not torqued evenly.

This can cause deformation of the raceway that could lead to vibration, loss of accuracy and premature bearing failure. Ideally the amount of stick-out or recess depth in the housing after assembling the spindle should be measured using a depth micrometer, this enables the correct amount of squeeze to be set on the retaining cover.

In the example on the left side six retaining bolts have been evenly tightened. On the second graph the gap was too big and this can also cause deformation of the raceway.

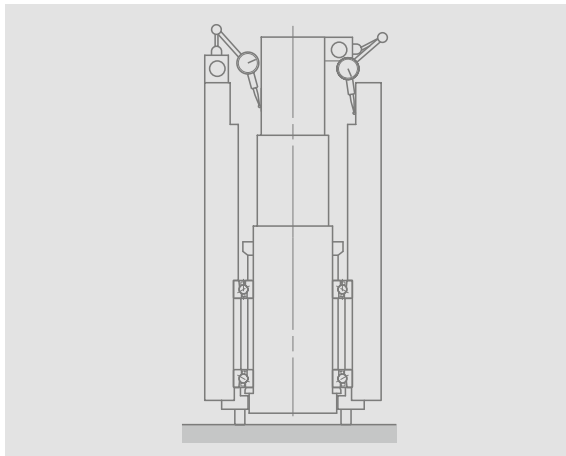

Housing Concentricity

The concentricity of the rear bearing housing can be measured as shown on the left. This value should be less than 10µm, ideally target 5µm.

Final runout checks should be conducted on the fully assembled spindle both radially and axially at the nose and radially at the rear. Target runout values should be no greater than 5µm.

1 to 2µm is typical for high-speed spindles.

The table shows the correct amount of gap to be left to allow the correct squeeze on the retaining cover.

Nominal bearing bore (mm)	Clearance between retaining cover and housing (mm)	Nominal bearing bore (mm)	Clearance between retaining cover and housing (mm)
20	0.01 to 0.03	140	0.03 to 0.05
25		150	
30		160	
35		170	
40		180	
45		190	
50		200	
55		220	
60		240	
65		260	
70	280	-	-
75	300	-	-
80	-	-	-
85	-	-	-
90	-	-	-
95	-	-	-
100	-	-	-
105	-	-	-
110	-	-	-
120	-	-	-
130	-	-	-

8. Useful Tip

When assembling cylindrical roller bearings, the outer ring is first pressed into the housing. Lightly grease or oil the raceway before inserting the spindle with inner ring/roller assembly. Rotate the bearing assembly while inserting, this minimises any damage to the outer raceway and rollers.

Mounting

Mounting Tapered Bore Roller Bearings – Calculation Method

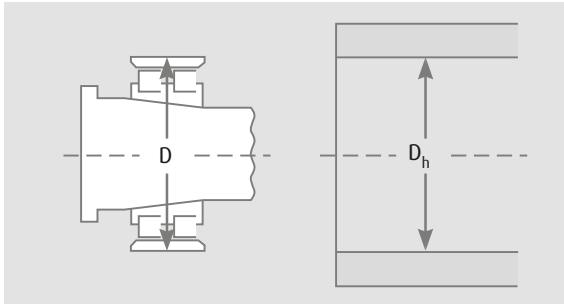

As stated on page 22 the mounted clearance of a cylindrical roller bearing is very important to the optimum performance of the spindle. When using tapered bore types it is recommended to set to a slight preload at the front of the spindle and a slight clearance to the rear of the spindle. This procedure can be easily accomplished with the use of special GN gauges (see next section).



However, an individual gauge is required for each bearing size so it is not always practical or economical to have a gauge available. This section will explain how to set the required preload or clearance without the use of a gauge.

Step 1

Determine the amount of shrinkage of outer ring raceway diameter due to fitting in the housing. Δr_e (Shrinkage) can be calculated or measured.

Calculation Method

$$\Delta r_e = (D_h - D) \times h$$

(If $\Delta r_e \geq 0$, $\Delta r_e = 0$)

D_h: Bore diameter of housing

D: Outer diameter of outer ring

h: Reduction factor

(NN30xx, N10 series: 0.62)

(NN39, NN49 series: 0.70)

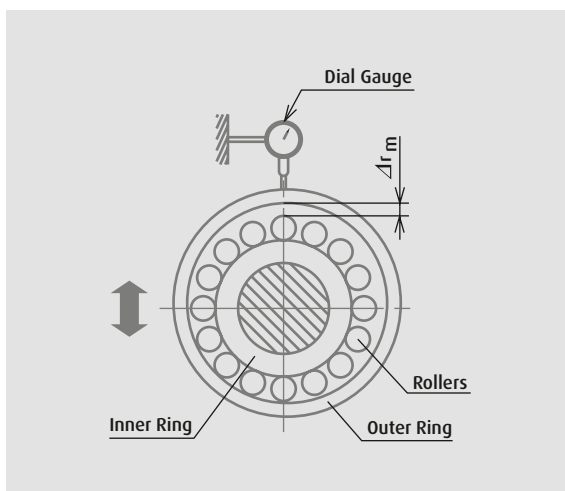

Measured Method

Ensure that the outer ring and housing are the same stable temperature. Using a cylinder gauge measure the bore of the outer ring in four different places before inserting into the housing.

Insert the outer ring into the housing and repeat measurements. Using average measurements calculate amount of shrinkage (if any) and record.

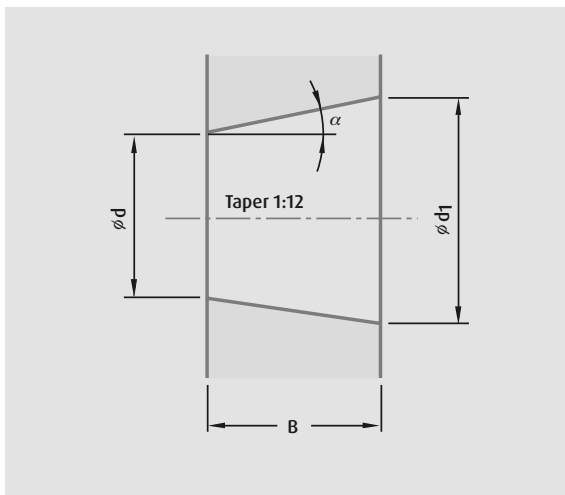
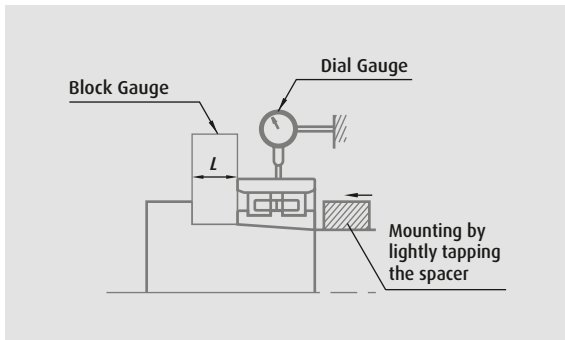

Step 2

Determine the initial Radial clearance Δr_m . Remove the oil on the taper surface of the shaft and bore of the inner ring. Mount the inner ring assembly and place the outer ring over the rollers. Apply a dial gauge to the outer diameter of the outer ring (*1).

Step 3

Lightly tighten the locknut; this will drive the bearing up the 1:12 taper and expand the bore to reduce the radial internal clearance (RIC) of the bearing. Measure the free radial play by moving the outer ring in a downward and upward motion. Continue to tighten the locknut (i.e. moving the bearing up the taper) until the radial clearance measured is approximately 0.005mm (*2).

Remarks:

- (*1) If the measurement takes too long, the temperature of the outer ring may rise to body temperature resulting in an erroneous measurement. Wearing gloves is recommended to reduce heat transfer.
- (*2) If there is an excessive amount of play, the outer ring may have deformed into an ellipse when pressed by hand. This would result in an erroneous measurement. Therefore, 0.005mm of play is acceptable (0.005mm is the target value, but 0.001mm to 0.002mm is also acceptable).

Step 4

When Δr_m is set to approximately 0.005mm, record this value and measure the distance from the shaft shoulder to the inner ring end face (distance L) using slip gauges (block gauges).

Care should be taken when using the slip gauges since the inner ring can be tilted by the action of inserting the slips. Record the average distance from two to three measurements (*3).

Mounting

Mounting Tapered Bore Roller Bearings – Calculation Method

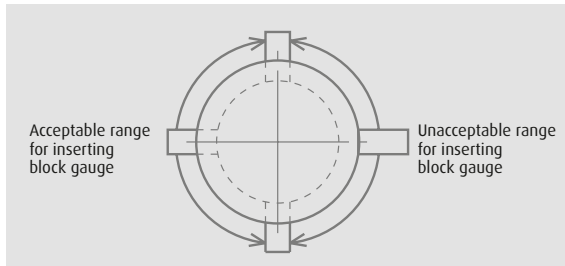

Hollow Shaft Ratio and Coefficient K

Hollow shaft ratio k_0	Coefficient K
45-55%	14
55-65%	15
65-75%	16

Step 5

Calculate the required length L_a for the spacer manufacturing according to the target clearance or preload required using the following formula:

$$L_a = L - (K (\Delta r_m - \Delta r + \Delta r_e))$$

L_a : Finish dimension of spacer for setting post mounting radial clearance

L : Width of block gauge (measured result from Step 4)

Δr_m : Movement of the outer ring in a radial direction (measured result from Step 3)

Δr : Target Radial clearance or Preload after mounting

Δr_e : Shrinkage of outer raceway diameter due to fitting in the housing

K : Coefficient (conversion value which includes shrinkage of a hollow shaft with a 1/12 tapered hole) - (for solid shaft $K = 12$)

k_0 : Hollow shaft ratio = $A/B \times 100$

A: Shaft bore diameter B: Shaft outer diameter

Example of Calculation

$L = 20.55$
(distance between inner ring and shoulder)
 $\Delta r_m = 0.007$ (measured RIC (Lift))
 $\Delta r = -0.002$ (required RIC) i.e. preload
 $\Delta r_e = 0.004$ (reduction in RIC due to housing)
 $K = 15$ (hollow ratio of shaft is 60%)

$La = 20.55 - (15 \times (0.007 - (-0.002) - 0.004))$
(Be careful of sign notation - (-) = +)

$La = 20.475\text{mm}$

If a solid shaft was used the value of K is 12
i.e. 1:12 taper

In this case the La (spacer width) = 20.490mm

Remarks:

(*3) For the measurement of dimension L, the value obtained is produced by inserting the block gauge in the left half of the zone shown in Step 5. The right hand side shows that the gauge cannot be inserted (This is due to tilting that occurs between the shaft shoulder and inner ring end face.)

9. Useful Tip

The formula can be made simpler by using the solid shaft coefficient of 12 for all hollow shafts. This would result in a slightly lower preload but is easy to remember from the taper ratio of 1:12 i.e. for every 12 μm movement up the taper the internal clearance is reduced by 1 μm .

In this case using the same values as above but with $K = 12$, $La = 20.49\text{mm}$. The difference in radial movement is only $(20.49 - 20.475) / 12 = 1.2\mu\text{m}$. This would give a value of 0.8 μm lower than the targeted 2 μm preload (this is safer than over preload).

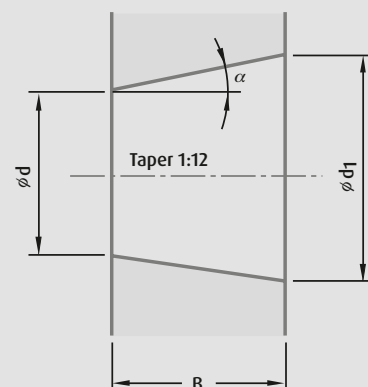

Mounting

Mounting Tapered Bore Roller Bearings – Gauge Method

Mounting of Tapered Bore Cylindrical Roller Bearings – Gauge Method

As stated on page 22 the mounted clearance of a cylindrical roller bearing is very important to the optimum performance of the spindle. When using tapered bore types it is recommended to set to a slight preload at the front of the spindle and a slight clearance to the rear of the spindle.

This procedure can be easily accomplished with the use of special GN gauges. A GN gauge is an instrument for matching the tapered section of a shaft to the tapered bore of a bearing when mounting a cylindrical roller bearing with a tapered bore onto a machine tool spindle. After mounting, the GN gauge is used for precise control of the bearing's radial internal clearance. This instrument is especially effective when a cylindrical roller bearing is used with radial preload.

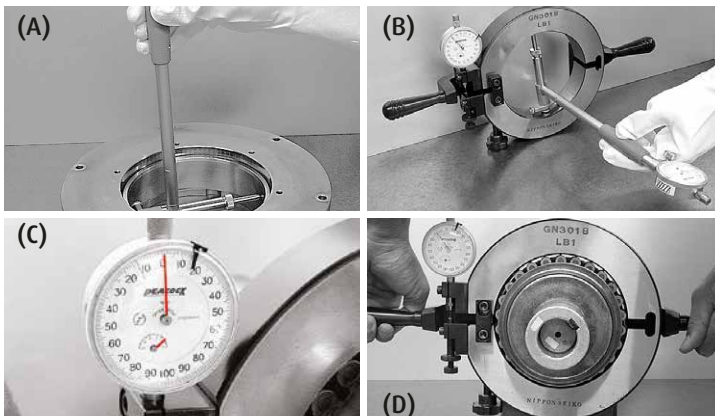
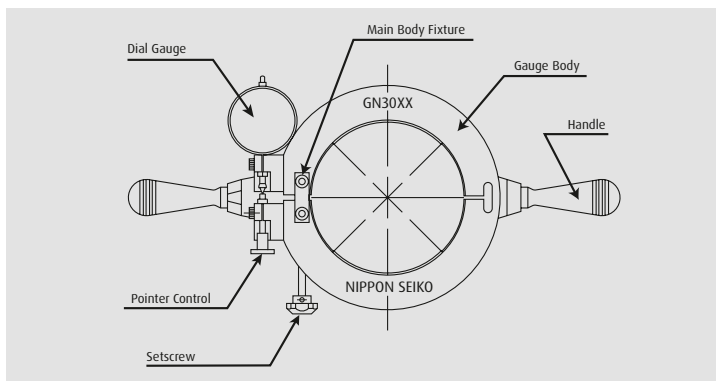

Method

Step 1

Insert outer ring into the housing. (This is usually between $2\mu\text{m}$ clearance and $2\mu\text{m}$ interference.)

Step 2

Measure outer ring bore using a cylinder gauge at about four different locations. Determine the average for the measurements and set the gauge to zero. **(A)** (Confirm that all components, outer ring in housing, inner ring and shaft, are the same temperature before setting to zero.)

Step 3

Adjust the inscribed diameter of the GN gauge. The idea is to set the bore of the GN gauge to replicate the bore of the outer ring after insertion in the housing. **(B)**

Loosen the bolt of the main body fixture on the GN gauge. Apply the cylinder gauge to the inscribed diameter surface of the GN gauge and adjust the setscrew to the setting of the dial on the cylinder gauge to zero (see diagram on the left). (Use the GN gauge in an upright position to avoid inaccuracies due to its own weight.)

Step 4

Gauge correction factor is necessary. Using the pointer control on the GN gauge, adjust the main pointer to the red line on the front glass of the dial gauge. Confirm that the short needle is around the 2 position on the secondary dial. **(C)** (Gauge correction corrects for elastic deformation of the rollers due to measuring pressure on the gauge. The amount of correction for each gauge is determined upon shipment of the gauge.)

Step 5

Mount the cleaned inner ring (not yet greased) onto the shaft and tighten the shaft locknut lightly.

Step 6

Expand the GN gauge by adjusting the setscrew by about 0.2 to 0.3mm. Place centrally over the inner ring rollers and release the setscrew to allow the GN gauge to spring closed over the rollers. **(D)**

Step 7

Oscillate the GN gauge lightly in the peripheral direction as shown to allow the dial indicator to stabilise. Tighten the shaft locknut until the gauge reads zero.

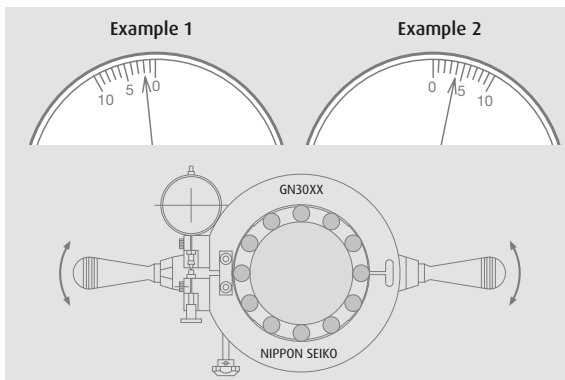

Reading the Dial Gauge

If the dial needle is in the position clockwise to the zero it indicates that there is clearance present. If the dial needle is in the position anti-clockwise to the zero it indicates that there is preload present. The actual amount of clearance or preload is $\frac{1}{2}$ the indicator reading. In **example 1** the indicator reads 2 anti-clockwise. This indicates $-1\mu\text{m}$ clearance or $1\mu\text{m}$ preload. In **example 2** the indicator reads 4 clockwise which equals $2\mu\text{m}$ clearance.

10. Useful Tip

In the case where a thrust bearing is used adjacent to the roller bearing, it is better to make an assembly spacer to incorporate the width of the thrust bearings for use while setting up. This will prevent damage pressing the thrust bearings on and off the spindle a number of times.

Step 8

Widen the GN gauge using the adjusting screw and carefully lift off the assembly avoiding any impact with the rollers.

Step 9

Measure the clearance between the end face of the roller bearing inner ring and the shoulder of the shaft or dummy spacer. Using block or slip gauges measure the gap around the circumference in a number of positions (ideally 4) and record the average value. The final spacer should be manufactured to this length.



Step 10

Remove the locknut and bearing from the shaft. Fit the adjusted spacer and re-assemble the bearing and locknut.

Step 11

Re-check the value of the clearance/preload by placing the widened gauge over the rollers and adjust the screw to allow gauge to contact the rollers. Using the guide in step 7 re-check to ensure that the target values of clearance/preload were achieved.

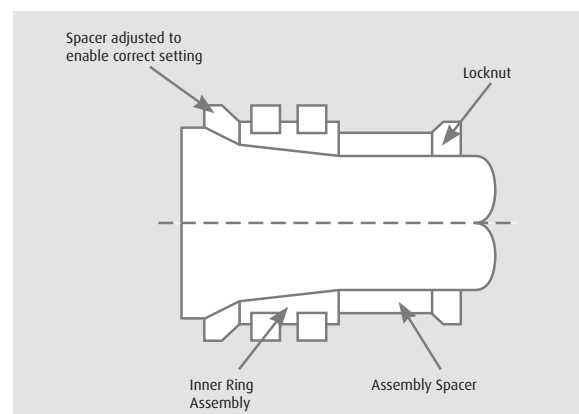

Mounting Classical Spindle Arrangements

A Typical Medium Speed Spindle

Spindle Type:
Type 1

Typical Application(s):
Turning machines and
general machining centres

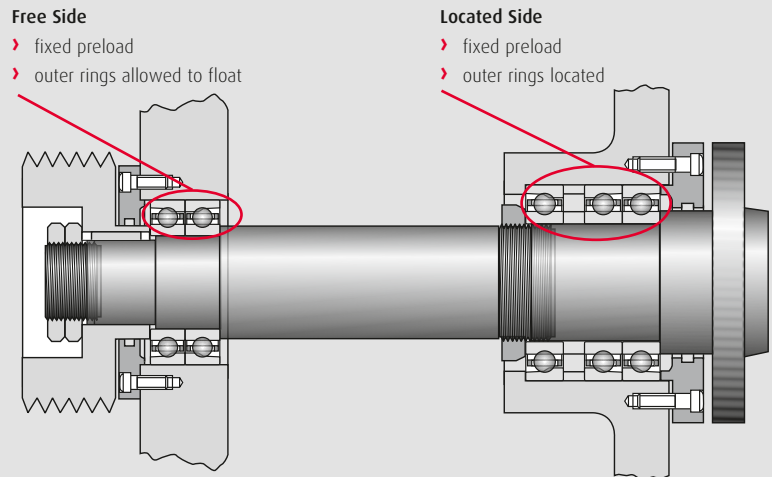

A Typical Workhead Spindle

Spindle Type:
Type 2

Typical Application(s):
Turning machines and
general machining centres

Note: All bearings are preloaded together i.e. one set.
Both spacers need to be identical in length

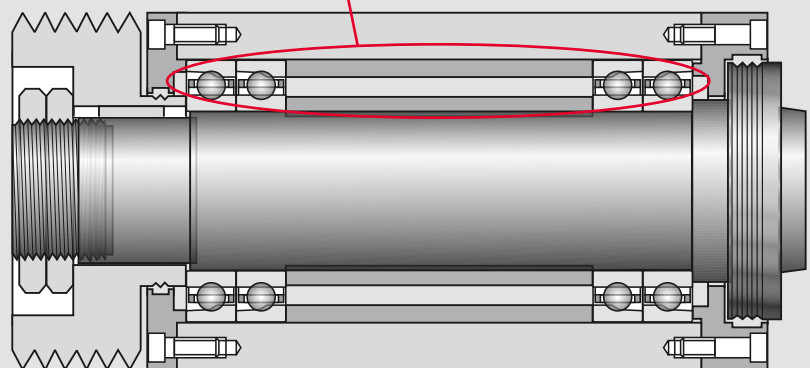

A Typical High-Speed Spindle

Spindle Type:
Type 3

Typical Application(s):
High-speed grinding spindle

Note: Work end bearing located, preload
applied through springs at rear bearing

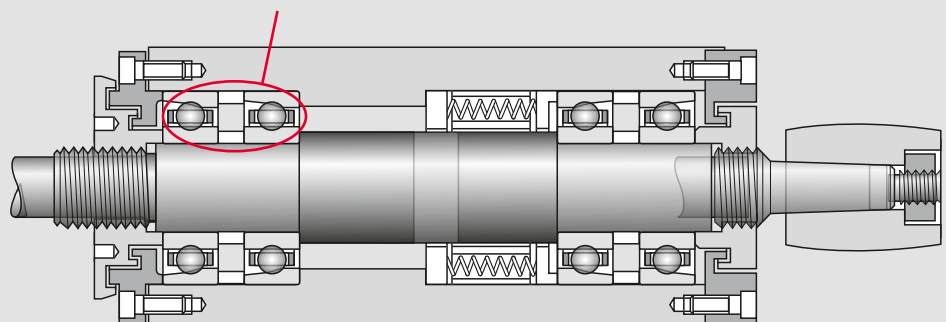

Mounting

Summary of Spindle Arrangements

Confirm Bearing Shaft and Housing Fits

- › See NSK bearing box label for exact bearing bore and OD dimensions to one micron.
- › Measure the shaft OD and housing bore at the bearing locations.
- › Calculate the bearing shaft and housing fits and compare with OEM specifications or NSK guidelines.
- › Excessive bearing-shaft interference or insufficient bearing-housing clearance fit may lead to excessive bearing preload and seizure.
- › Insufficient bearing-housing clearance at the rear-side may prevent the rear-side bearings and shaft from floating within housing bore during axial thermal expansion.



D	-3	f	-1
d	-1	b	-1
C	-57		

D = OD
d = Bore
C = Width

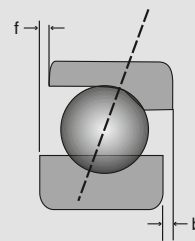

Mounting Heavy Duty Spindle

Cylindrical Roller Bearings (Tool-Sides and Rear-Sides)

- › Double-row cylindrical bearings (NN3XXX) with tapered bores allow for precise setting of internal clearance (between rollers and outer ring bore).
- › Check the bearing bore taper against shaft taper for a good match.
- › Radial clearance depends on OEM, spindle design, speed, operating temperature, etc. (consult OEM specs or NSK guidelines). Usual to target a 2µm preload.
- › Target outer ring to housing fit is 2µm loose to 2µm tight.
- › Tool-Side: Excessive preload (negative radial clearance) can result in high bearing running temperature and seizure.
- › Rear-Side: This bearing is usually mounted with greater radial clearance than tool-side to ensure the shaft floats within housing during axial thermal expansion. Usual to target a 5µm clearance.

Thrust Angular Contact Ball Bearings

- › Thrust angular contact ball bearings can be types BAR (30°) or BTR (40°).
- › These bearings are designed to take only thrust loads due to special OD tolerance.
- › Angular contact bearings with standard OD tolerance may fail.
- › The double-row cylindrical roller bearing will support the radial load.

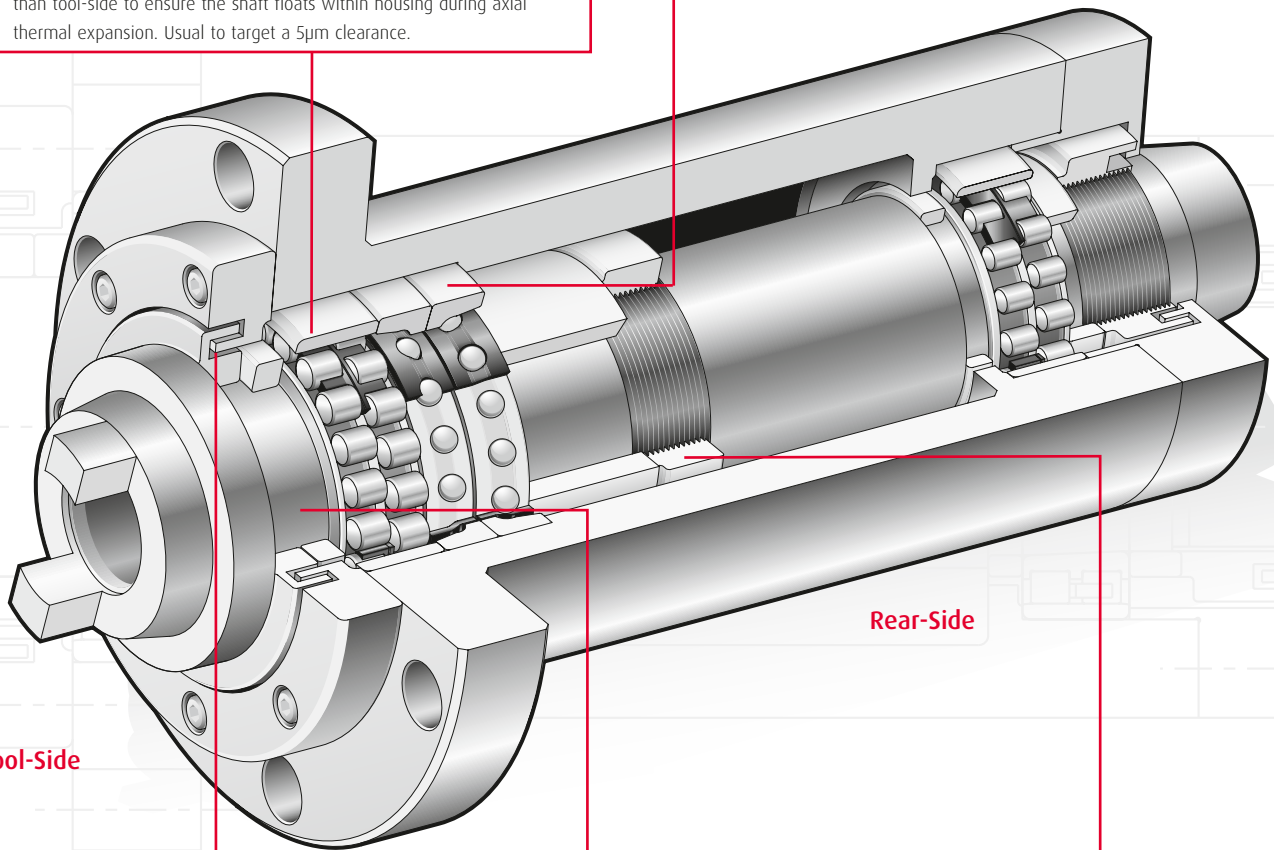

Tool-Side

Rear-Side

Tool-Side Labyrinth Seal

- › Most spindle designs should include a labyrinth seal to minimise contamination.
- › Labyrinth designs that incorporate an air barrier should use clean, dry air.
- › Avoid aiming coolant directly into spindle nose.

Locating Spacers

- › This spacer is adjacent and forward of the double-row cylindrical roller bearings (NN3xxx).
- › Spacer width determines the bearing's position along the shaft taper and establishes the mounted radial internal clearance.
- › Grind spacer to specific width after setting radial internal clearance and before final mounting of NN3xxx bearing.

Clamping Nut

- › Sufficiently tighten clamping nut to prevent bearings from backing off.
- › If bearings become loose, the bearing set may lose preload and rigidity, the spindle may not machine properly or it may make noise.
- › Check shaft-bearing assembly straightness after tightening.

Mounting

Medium to High-Speed Spindle

Outer Cap

- › Most spindle designs include an outer cap whose male register surface should lightly compress the bearing's outer ring.
- › Suggested axial compression: 10-30µm.
- › The male register's surface should be flat and parallel to the outer cap mounting flange surface that contacts the housing. This will ensure even clamping pressure against the bearing outer ring.
- › Excessive and/or uneven clamping pressure can result in bearing noise or loss of preload.

Clamping Nut Spacer

- › This spacer is between the bearing inner ring and clamping nut (most spindle types).
- › Spacer ensures even clamping around the bearing's inner ring.
- › Mating surfaces should be flat and parallel.

Rear-Side Angular Contact Ball Bearings

- › Rear-side bearings and shaft must float within housing bore to allow axial thermal expansion. Therefore, a clearance fit should exist between the rear-side bearing OD and housing bore.
- › Calculate clearance fit with housing bore measurement and bearing OD from box label.
- › Compare calculated clearance fit with OEM specification or NSK guidelines.
- › Spindle rear-side bearings usually have light preload or less.
- › High-speed spindles may use a single-row cylindrical roller bearing instead of angular contact ball bearings, with a locating outer ring fit, the axial expansion is allowed by roller/outer bore movement.

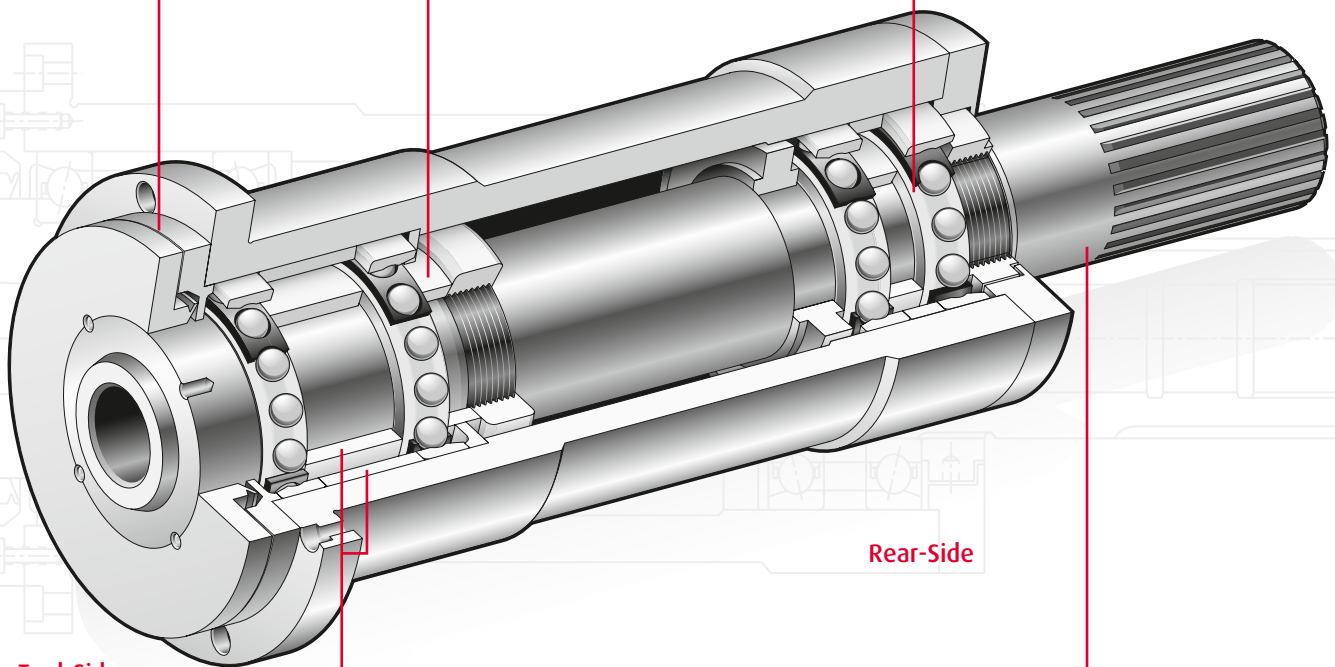

Tool-Side

Rear-Side

Bearing Spacers

- › Spacers between bearings increase bending rigidity at the spindle tool-side.
- › Spacers may lower bearing running temperature due to separation, depending on spindle design and operating conditions.
- › When necessary, bearing mounted preload can be reduced or increased by offsetting spacers.
- › Reducing preload may allow higher spindle speed or lower bearing operating temperature, especially for grease-lubricated bearings.
- › Increasing preload can be used to increase spindle rigidity.

Shaft Alignment

- › Check shaft straightness at this location relative to tool-side after final assembly.
- › Check spindle alignment with drive source.
- › Avoid excessive belt tension for belt-driven spindles.

Post-Mounting Preload Checks

Preload Checking

The final preload after assembly is important, factors such as fits, spacer compression, locknut torque and correct seating can affect the preload. If the final preload is larger than required, the rigidity will be increased, which is a positive aspect, but the temperature will also be increased which could cause a seizure under certain conditions. If the preload is too low, temperature will be lower but there might not be adequate stiffness to support external loads.

Methods of Checking Preload

There are three methods for checking the preload in mounted angular contact bearings depending on the amount of preload and accuracy required.

1. Starting Torque Method

This is obtained by measuring the tangential force of the spindle by either using a spring balance or rotary torque devise as shown below:

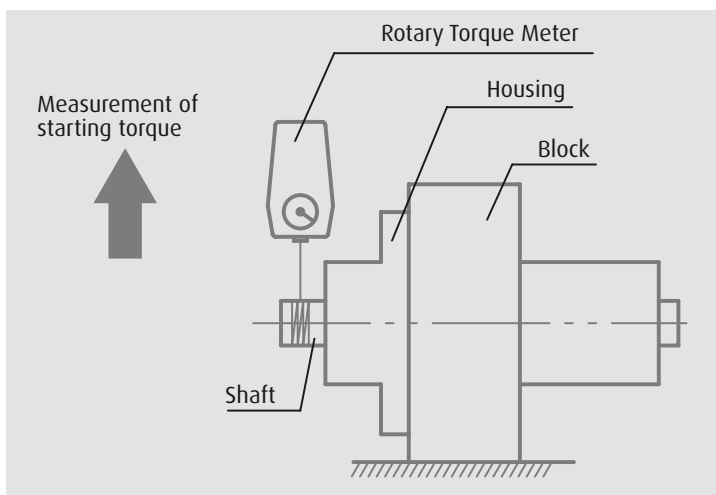

Care should be taken with this method since oil film formation in the ball contact area can cause stick-slip, this can give a higher than actual value. The preload is obtained from the relationship between measured starting torque and preload. An example is given in the graph on next column:

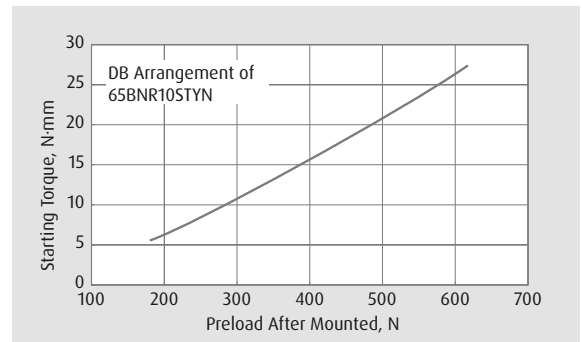

This method is best suited to applications where the preload is high. Most high-speed machine tool spindles use a lower preload and in this case the error can be large.

2. Force Deflection Method

For this method a thrust load is axially applied to the spindle and its axial displacement is directly measured as shown below. The preload is obtained by the relationship between axial displacement and preload, see example graph below:

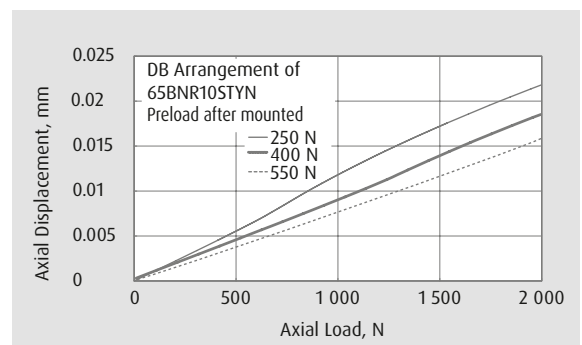

This method is better suited to lower preload applications. If the preload is very high it may be necessary to use special hydraulic equipment to apply a large enough axial load. For example if the axial rigidity is 200N/μm, an axial load of 2000N will be required to deflect the spindle by 10μm. If loads are excessive, elastically deformation can occur in both the bearing internals and associated machine parts; this could result in a measured preload being lower than actual value.



3. Natural Frequency Method

This is by far the most sensitive and repeatable method but the results can be affected by the spindle design and more sophisticated equipment is required to measure the natural frequency of the shaft assembly.

The shaft is vibrated in the axial direction by lightly tapping with a hammer and measuring the resonant frequency with an accelerometer coupled to a vibration analyser. (See diagram to right).

The actual preload after mounting can be found by the relationship of resonant frequency (F_z) to axial spring stiffness of the shaft assembly (K_a) and the relationship between stiffness and preload.

Natural Frequency Formula

In some cases a special hammer containing a transducer can be used to impact against the shaft assembly, this allows the impact force to be measured. In this situation the preload can be calculated directly from the formula without the need of graphs. F_z is found from the spectrum analyser, the shaft assembly is weighted (M) and K_a = Force/movement (movement measured by accelerometer in μm).

Summary of Methods

The resonant frequency method is not suitable for applications using bearings with clearances such as N or NN Cylindrical roller bearings that are not preloaded.

Axial Rigidity

The axial rigidity can be checked by comparing the values of deflection obtained i.e. if $10\mu\text{m}$ deflection is the result of an axial load of 1000N, the axial rigidity is $1000 / 10 = 100\text{N}/\mu\text{m}$.

Values for axial rigidity for pairs of bearings are given in the NSK Global catalogue, these values are before mounting and are a guide only; the mounted values will be higher due to fits and clamping forces etc. The effects of fits and clamping forces on stiffness can be calculated by NSK on request.

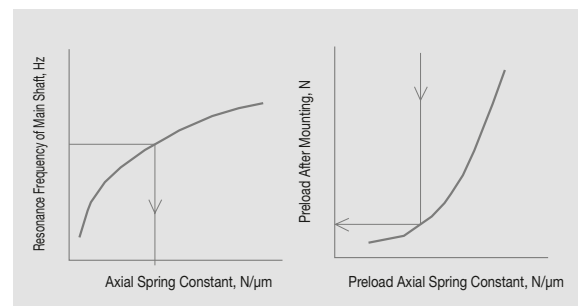
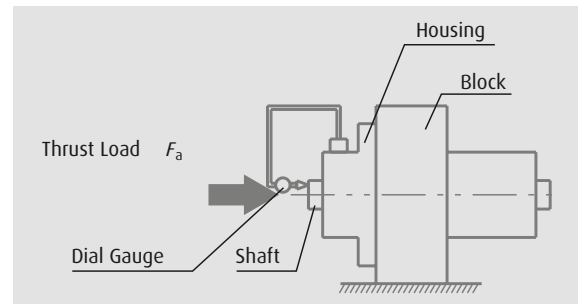

$$F_z = \frac{1}{2\pi} \sqrt{\frac{K_a}{m}} \times 1\,000$$

K_a : Axial spring constant of bearing ($\text{N}/\mu\text{m}$)
 F_z : Resonance frequency (Hz)
 m : Mass of rotating body (kg)

	Advantage	Disadvantage
Starting torque method	Used for heavy preload. If starting torque is high, measurement error is small.	Not good for light preload. If starting torque is small, variation of measurement is large.
Thrust static rigidity method	Used for light preload.	Not good for heavy preload. Loading equipment is too large scale. Affected easily by deformation of contact part other than bearing.
Natural frequency method	Measurement accuracy is high. Good repeatability.	Influence of spindle fixing condition should not be ignored.

Post-Mounting Alignment and Balance

Balance

Any unbalance of rotating components will cause repeated stress or excessive vibrations due to centrifugal force. This is especially true for spindle rotating at high-speeds i.e. above 1 million $d_m n$.

$d_m n$ is a speed factor used within the bearing and lubrication industry and is simply the mean bearing diameter in mm multiplied by the rotational speed in rpm and is usually expressed in terms of millions or part millions. EG. A 7014 bearing has a mean diameter of 90mm, if it was operating at 12000rpm, the $d_m n$ would be $90 \times 12000 = 1.08 M d_m n$, and classed as high-speed in need of balancing.

Units of unbalance are either expressed in g-mm (gram millimetres) or using the ISO or ANSI system a G number, which is a vibration velocity expressed in mm/sec (millimetres/second).

For example, G1.0 corresponds to a free spinning vibration of 1.0 mm/sec and is typical for high accuracy grinding machines.

G Grades

- 0.4 Gyroscopes, Ultra precision grinders.
- 1.0 High-Speed grinding machines, jet engines, small high-speed motor.
- 2.5 Medium to large electric motors, Machine tool drives.
- 6.3 General Machine tools, cylinders and rollers for printing machines.

The grades continue up to 4000.

Alignment

There are two basic types of misalignments: angular and offset. In reality most applications have a combination of both. If misalignments are not minimised, the resulting moment loads on the bearing can cause premature failure.

Vee Drives

Spindle assemblies using V-belts should have the misalignment between the spindle shaft centre and motor shaft centre less than 0.1mm.

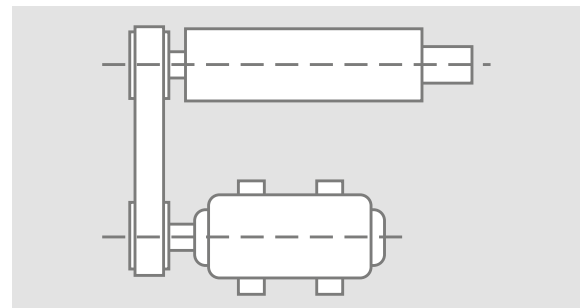

Couplings

Care should be taken when using direct drive couplings. For high-speed, special couplings will be necessary.

Coupling joints should have the misalignment between the spindle shaft centre and motor shaft centre corrected to 0.01mm or less.

Remember that both offset and angular misalignment can occur with direct drive coupling:

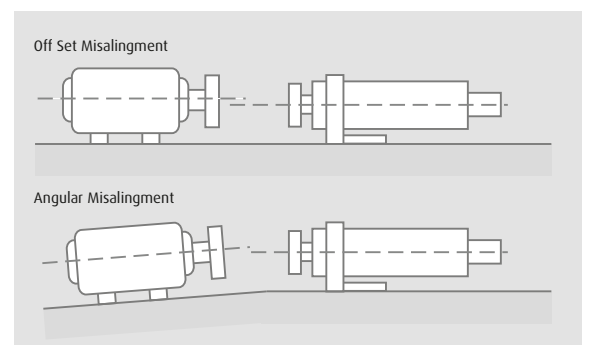

Misaligned shafts can result in:

- › Vibration of the spindle
- › Increased bearing load
- › Damage to the bearings
- › Poor surface finish of the work
- › Increased energy consumption
- › Premature bearing failure

Post-Mounting Bearing 'Run-in' Procedures

'Run-in' Procedures

'Running in' is very important to the life of the bearings. During this final process of the mounting procedures it will help you determine if there are any problems with the spindle. The 'run-in' process is aimed at channelling excess grease out of the way of the rolling elements. An improper run-in will result in higher than normal temperatures in the bearing and can ultimately cause early failure of the bearings due to the break down of the grease. There are two methods of the run-in processes; continuous run-in and intermittent run-in.

Continuous Running Procedure

Continuous running works by gradually increasing the operating speed from the low speed zone. Although somewhat time consuming, this procedure helps machine operators to detect potential problems related to the main shaft, thus avoiding costly damage to the bearings.

Procedure (This process can take up to 18 hours)

1. Begin at a reasonably low operating speed.
2. Monitor for temperature rise.
3. Stabilise the temperature.
4. Continue incremental increases of operating speed until reaching maximum operating speeds.

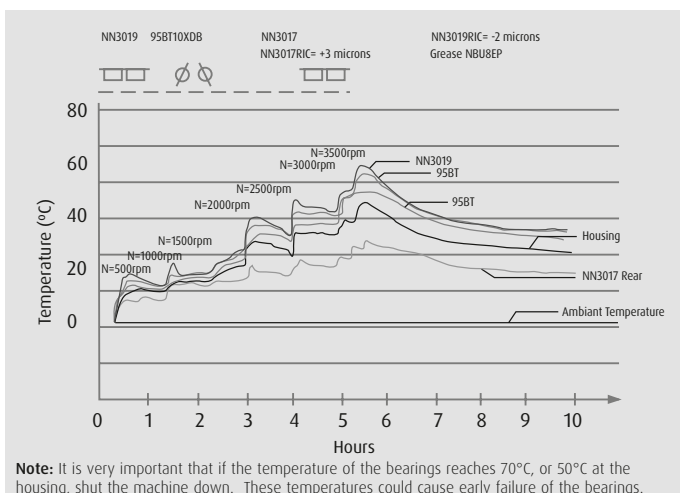

Intermittent Running Procedure

Intermittent running is a good option if you are short of time. The process works by stopping operation and stabilising temperatures before there is a rapid temperature rise, (this being caused by a sudden movement of grease across the path of the balls during operation).

Procedure

1. First take the maximum operating speed and divide it into eight to ten stages to determine the maximum target speed for each stage.
2. Each stage is divided into 10 cycles that are approximately one minute long.
3. During each cycle, rapidly accelerate the spindle assembly to the target speed for the current stage, and then decelerate back to zero, and rest for a period i.e. 40 seconds.
4. Repeat this cycle about 10 times.
5. Continue moving up through the stages, following the above procedures, until you reach the target speed. i.e. if the maximum speed is 8000 min^{-1} the first target maybe 1000 min^{-1} , cycle ten times, and then move to 2000 min^{-1} and so on until 8000 min^{-1} .

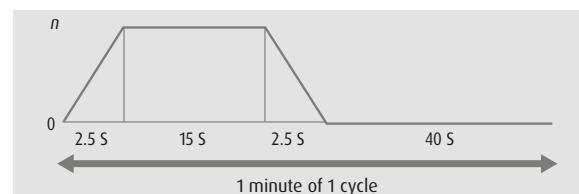

11. Useful Tip

It can be useful to initially run the spindle at a low speed say 5% of the maximum speed for about 15 minutes to gently align the grease within the bearing and to ensure there are no mechanical problems or loose nuts. After the 'running in' procedure has been completed it can also be useful to run for about 1 hour at the maximum operating speed.

Post-Mounting Troubleshooting

Cause of High Temperature

After mounting has been completed, a test run should be conducted to determine if the bearing has been mounted correctly.

It is best to monitor the temperature directly with a thermocouple on the outer ring of the bearing, if this is not possible, then the temperature on the outside of the housing will give a general indication.

The bearing temperature should rise gradually to a steady level within one to two hours depending on the size of the equipment and the power consumption after start up. If the bearing experiences trouble or if there is some mounting problem, the bearing temperature may increase rapidly and become abnormally high.

The causes of high temperature can be a number of things ranging from excessive amount of lubricant causing high frictional heat due to churning, to insufficient lubricant that could cause starvation and high contact friction. In the latter case it could be some time before the high temperature occurs but in the case of too much lubricant, the high temperature usually appears at the start.

Other causes of high temperature could be insufficient bearing clearance, incorrect mounting or excessive friction at the seals. In the case of high-speed applications, the wrong bearing type, lubricant or lubrication method could lead to abnormally high and unstable temperatures.

Below is a table showing reasons for high temperature, vibrations, lubricant leakage and the countermeasures.

	Cause	Countermeasure
Abnormal temperature rise	Excessive amount of lubricant	Reduce amount of lubricant or select stiffer grease.
	Insufficient or improper lubricant	Replenish lubricant or select a better one.
	Abnormal load	Improve the fit, internal clearance, preload, or position of housing shoulder.
	Incorrect mounting	Improve the machining accuracy and alignment of the shaft and housing, accuracy of mounting, or mounting method.
	Creep on fitted surface, excessive seal friction	Correct the seals, replace the bearing, or correct the fitting or mounting.
Vibration (radial runout of shaft)	Brinelling	Replace the bearing and use care when handling and mounting bearing.
	Flaking	Replace the bearing.
	Incorrect mounting	Correct the squareness between the shaft and housing shoulder or sides of spacer.
	Penetration of foreign particles	Replace or clean the bearing, improve the seals.
Leakage or discolouration of lubricant	Too much lubricant. Penetration by foreign matter or abrasion chips	Reduce the amount of lubricant, select a stiffer grease. Replace the bearing or lubricant. Clean the housing and adjacent parts.

Cause of Noise

Acoustic or other instruments can check bearing noise. Abnormal conditions are indicated by a loud metallic noise or other irregular noises.

Possible causes of noise include: incorrect lubrication, poor alignment of the shaft and housing, or external contamination entering the bearings. Below is a chart of possible causes and countermeasures:

Irregularities		Possible cause	Countermeasures
Noise	Loud metallic sound ¹	Abnormal load	Improve the fit, internal clearance, preload position of housing shoulder, etc.
		Incorrect mounting	Improve the machining accuracy and alignment of shaft and housing, accuracy of mounting method.
		Insufficient or improper lubricant	Replenish the lubricant or select another lubricant.
		Contact of rotating parts	Modify the labyrinth seal, etc.
	Loud regular sound	Dents generated by foreign matter, corrosion, flaws, or scratches on raceways	Replace or clean the bearing, improve the seals and use clean lubricant.
		Brinelling	Replace the bearing and use care when handling bearings.
		Flaking on raceway	Replace the bearing.
	Irregular sound	Excessive clearance	Improve the fit, clearance and preload.
		Penetration of foreign particles	Replace or clean the bearing, improve the seals and use clean lubricant.
Flaws or flaking on balls		Replace the bearing.	
Abnormal temperature rise	Excessive amount of lubricant	Reduce amount of lubricant or select stiffer grease.	
	Insufficient or improper lubricant	Replenish lubricant or select a better one.	
	Abnormal load	Improve the fit, internal clearance, preload or position of housing shoulder.	
	Incorrect mounting	Improve the machining accuracy and alignment of the shaft and housing, accuracy of mounting or mounting method.	
	Creep on fitted surface, excessive seal friction	Correct the seals, replace the bearing or correct the fitting or mounting.	
Vibration (radial runout of shaft)	Brinelling	Replace the bearing and use care when handling bearing.	
	Flaking	Replace the bearing.	
	Incorrect mounting	Correct the squareness between the shaft and housing shoulder or side of spacer.	
	Penetration of foreign particles	Replace or clean the bearing, improve the seals.	
Leakage or discolouration of lubricant	Too much lubricant. Penetration by foreign matter or abrasion chips	Reduce the amount of lubricant, select a stiffer grease. Replace the bearing or lubricant. Clean the housing and adjacent parts.	

Note ⁽¹⁾ Squeaking may arise from grease lubricated ball bearings or cylindrical roller bearings (medium to large size). This is especially true during winter when temperatures are low. In general, even though squeaking will occur, the bearing temperature will not rise, leaving fatigue or grease life unaffected. Consequently, such a bearing can continue to be used. If you have concerns regarding squeaking noise, please contact NSK.

Upgrading
Overview

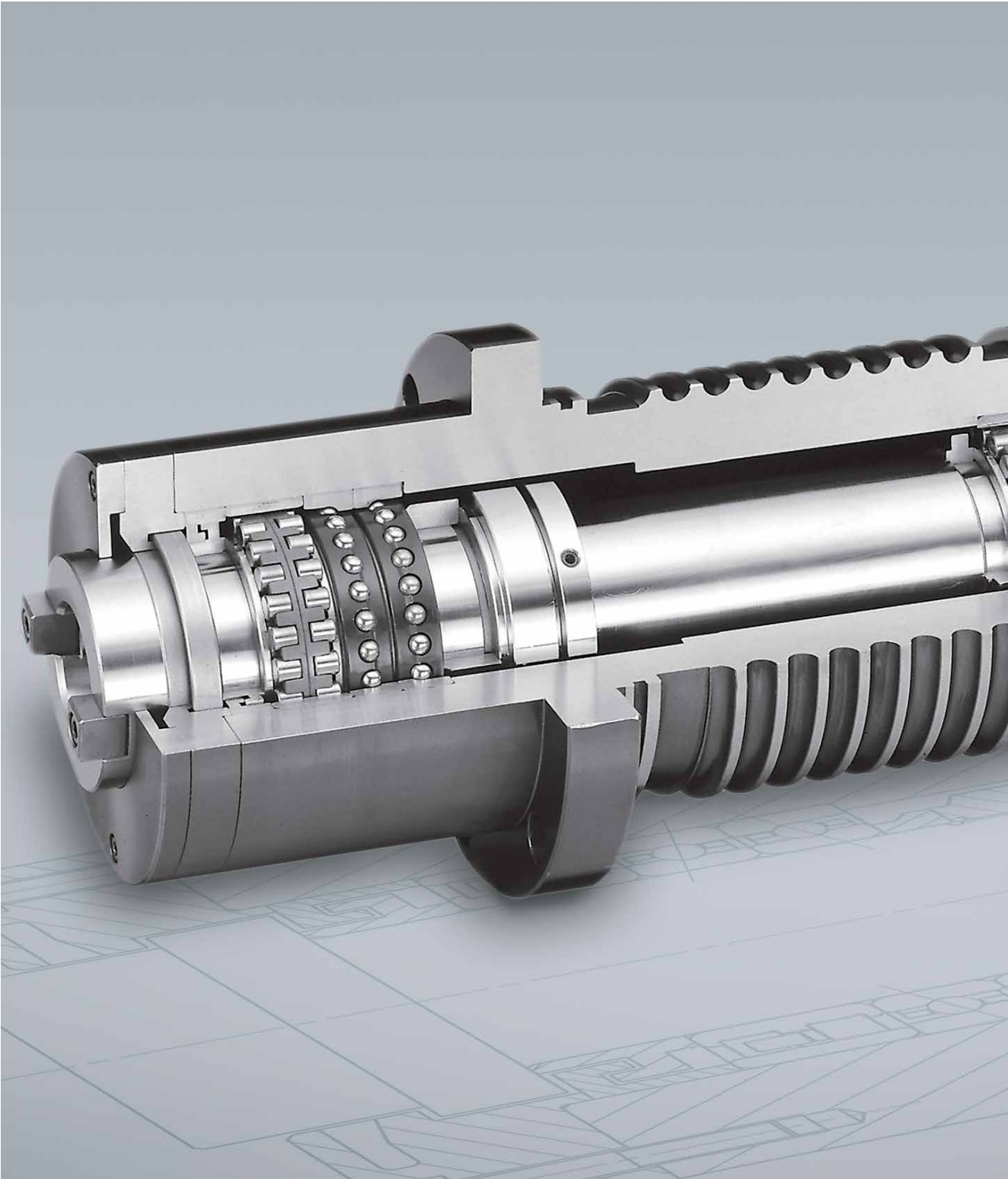

The following section shows how a spindle performance can be upgraded by changing from a conventional design to a special product designed specifically for certain applications. This section also shows where improvements can be made by using updated products such as sealed bearings instead of open bearings.

The following products are included here:

› **Robust Design**

Designed for low temperature generation or higher speeds. Both angular contact and cylindrical roller bearings available.

› **Improved Material**

Steel, ceramic and special NSK SHX or EP material choices are available for applications resulting in longer fatigue life under severe conditions.

› **Sealed Bearings**

Opportunity to eliminate contamination before and during operation resulting in longer grease life. Available for angular contact spindle bearings and ball screw support bearings.

› **Hybrid Bearings**

Bearings with ceramic balls, resulting in lower temperature, higher speed, higher accuracy, reduced wear, higher stiffness and longer life.

› **TYN Cages**

Especially suitable for grease applications and used in angular contact bearings.

› **TB Cages**

Used to increase speed performance in cylindrical roller bearings.

› **TAC Conversions**

Converting from 60° double direction thrust bearings to the more easy to fit and lubricate BTR and BAR Series 40° and 30° contact angle enabling higher speeds.

Upgrading Robust Design – Angular Control

The 'Robust' design is a high-speed / low temperature range of bearings allowing higher performance for the same envelope size.

Benefits:

- › Low Heat Generation
- › High Seizure Resistance
- › Better Temperature Stability
- › Stable in High-Speed Operations

Designations examples:

S-Type	All steel	70BNR10STSULP3
H-Type	Steel rings/ceramic balls	70BNR10HTSULP3
X-Type	Special SHX material rings/ceramic balls	70BNR10XTSULP3
XE-Type	Special design same material as above	70BNR10XETSULP3

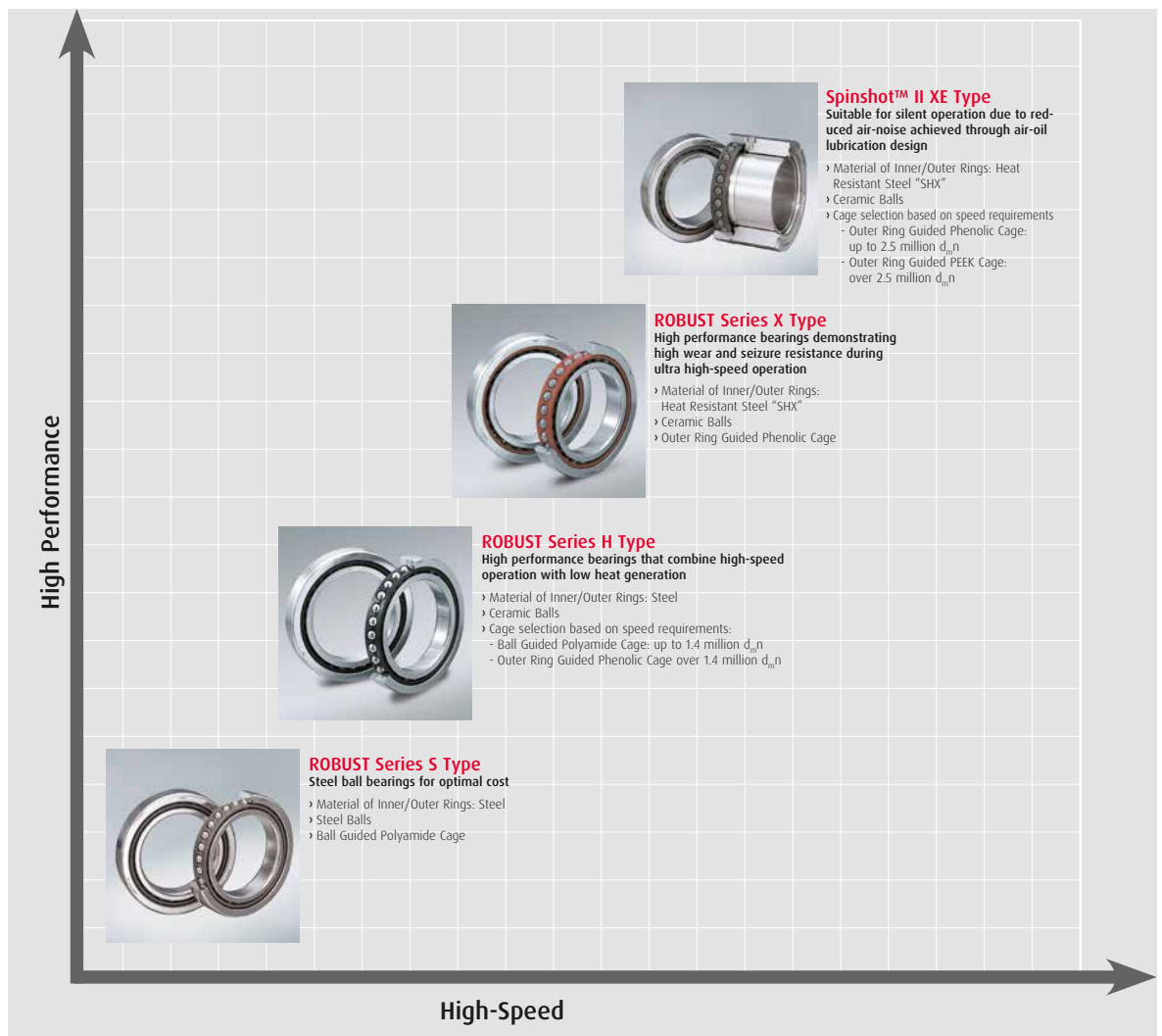

Upgrading Robust Design – Cylindrical Roller Bearings

The complete range of NSK cylindrical roller bearings are designed to achieve high-speed performance combined with high rigidity. At the top of this range is the 'Robust' series.

Benefits:

- › Low Heat Generation
- › Improved Seizure Resistance
- › Stable in Ultra-High-Speed

Designations examples:

Single row – Standard series	N1014BMR1KRCCOP4
Single row – 'Robust' series, RS type	N1014RSTPKRCCOP4
Double row – High Rigidity series	NN3014TBKRE44CCOP4
Single row – 'Robust' series, RX type	N1014RXTPKRCCOP4
Single row – 'Robust' series, RXH type	N1014RXHTPKRCCOP4

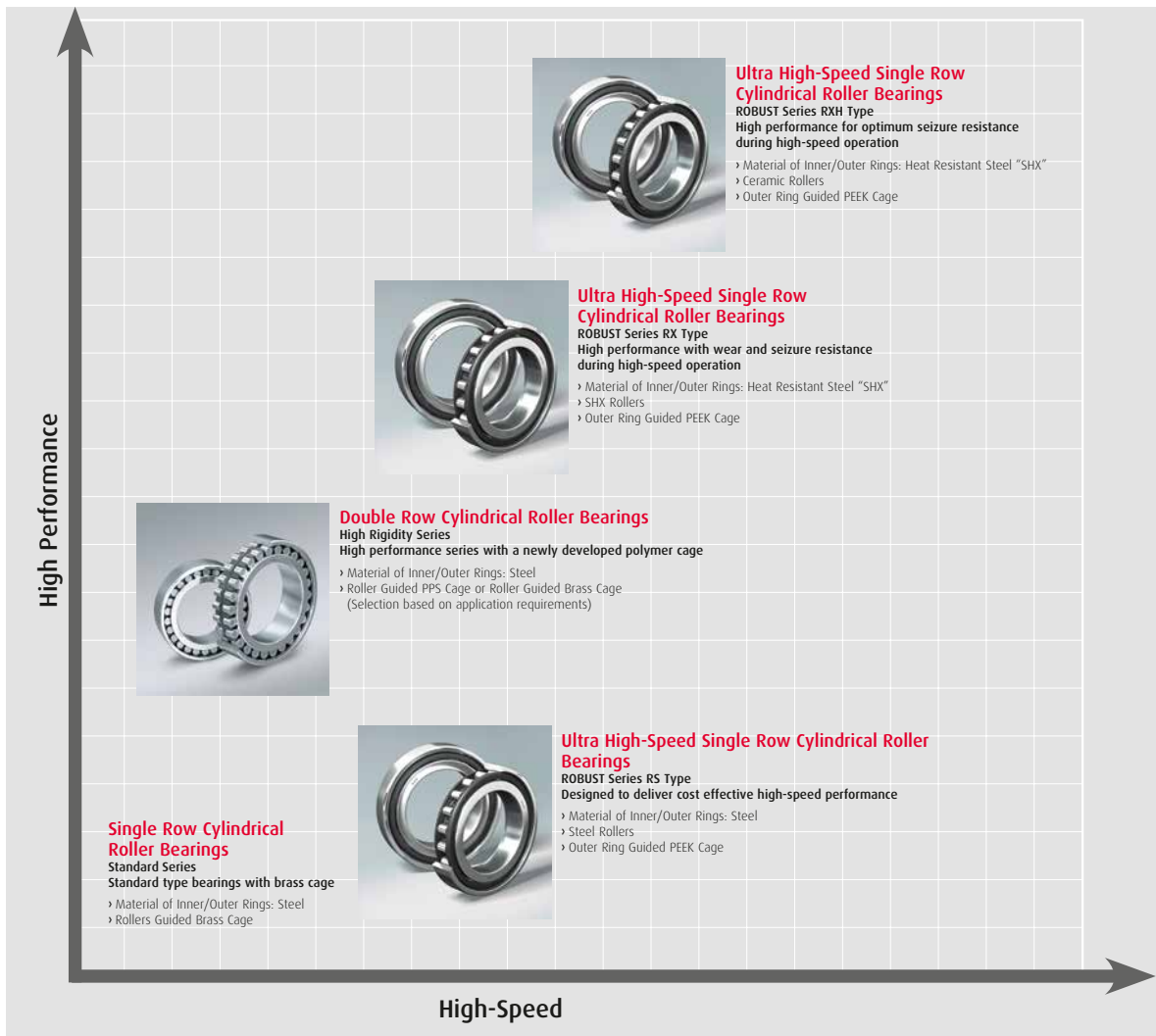

Upgrading Bearing Material

Three types of steel materials support long life and high performance of NSK Super – Precision bearings.

Z Steel

This is now the standard steel used for precision bearings. This steel is an improvement on the conventional carbon chrome bearing steel i.e. vacuum degassed steel (SAE52100, SUJ2). It is specially produced by reducing the amount of non-metallic inclusions, oxides and other inclusions such as Ti (Titanium) and S (Sulphur). Tests have proved that this significantly improves the bearing fatigue life.

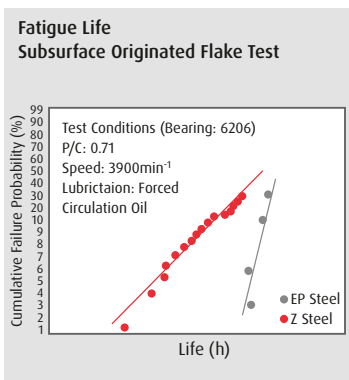
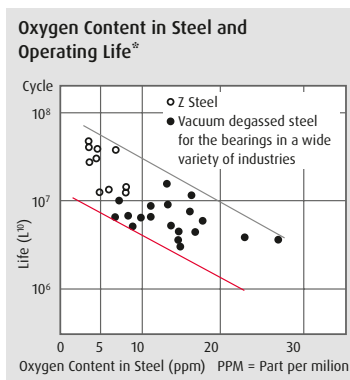

Z steel results in a fatigue life increase of 1.8 times longer than conventional Vacuum degassed steel. When calculating fatigue life of NSK precision bearings in Machine Tool applications which are relatively clean and not highly loaded, the fatigue life of Z steel can be increased by approximately 14 times.

EP Steel (Extremely Pure)

The number and size of particles within the steel affects the fatigue life of the material particularly under high loads. A new inspection process developed by NSK enabled the development of this extremely pure (EP) steel for use in high load applications. Compared to Z steel it can be seen that the fatigue life is superior. The graph also shows that the slope of the fatigue results for the EP steel is almost vertical, this is an indication of high reliability. All the Ball Screw Support (TAC) bearings are made from this EP material. **EP steel results in a fatigue life increase of 3 times longer than conventional Vacuum degassed steel.**

SHX Steel

This is a special material designed by NSK for Ultra high-speed applications. It is a highly heat and wear resistant steel using special NSK heat treatment technology.

At extreme speeds the wear resistance of the material is very important, this is particularly true for cylindrical roller bearings. Seizures can occur due to wear and high temperature.

The SHX material exhibits both wear and heat resistance similar or better than M50 (Aerospace steel used on main shaft bearings up to 300°C).

The SHX material is used for part of the 'Robust' range for both angular contact and cylindrical roller bearings. For the cylindrical roller bearing it offers speeds almost as good as ceramic roller bearings for a significantly lower price. This option is only available from NSK.

SHX steel results in a fatigue life increase of 4 times longer than conventional Vacuum degassed steel at 20% higher speed.

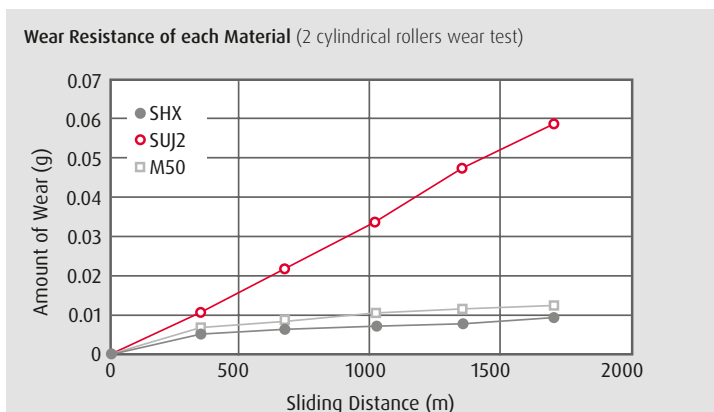

Upgrading Sealed Bearings

Upgrading to sealed bearings is a major advantage to increasing life and performance of spindle bearings. Sealed angular contact bearings are the same external dimensions as open bearings so interchange is easy.

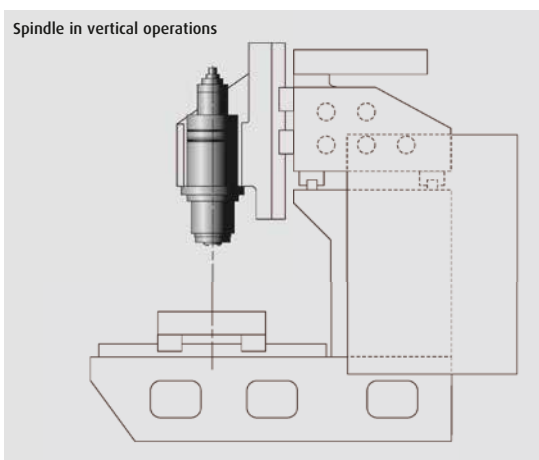

Benefits of Sealed Bearings

1. Time saving to end user, no grease fill operation – Bearings pre-greased by NSK

NSK greased bearings are filled with high performance grease. This saves the user time by eliminating the greasing process and ensures that the correct quantity of grease is applied in the correct position in ultra clean conditions.

2. Reduced down time – Eliminate contamination through poor handling

Sealed bearings prevent contamination entering the bearing during handling and fitting to the spindle. Grease in an unsealed bearing can attract dust and metallic debris. Contamination in the bearing will cause the raceways to wear and cause premature failure.

3. Better spindle performance – Prevents grease migration in vertical spindles

Spindles in vertical operations can vary in temperature due to grease falling out of the uppermost bearing into the path of the lower bearing. Sealed bearings prevent this occurring and because the seals are non-contacting type, the speed capability is the same as open bearings.

4. Higher accuracy due to reduced contamination – Prevents entry of contaminants in operation

The sealed bearing eliminates solid contamination entering the bearing during operation. This prevents noise and vibration in the bearing. Vibration can result in loss of accuracy of machined components.

5. Longer grease life – Seals prevent loss of grease and reduce ageing

A sealed bearing not only prevents premature failures due to contamination, but also extends the grease life by preventing grease loss during operation. This results in at least a 50% increase in life.

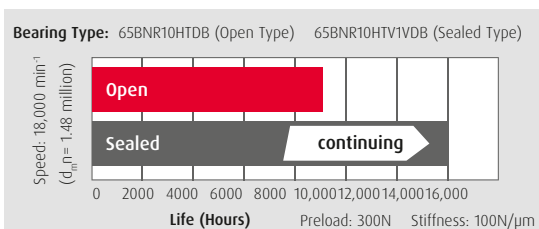

Upgrading Sealed Bearings

Standard Series

E.g. bearing number: 7010CTRV1VSULP3 **MTSX**

Ultra High-Speed Robust Series

E.g. bearing number: 60BNR10XTV1VSUEL3 **MTSX**

Designations System

Sealed bearings are available in two series: standard precision and High-Speed 'Robust' Precision from 30mm to 100mm bore. 'V1V' signifies a sealed bearing.



Summary of Benefits

- › **Grease in optimum quantity and position**
Time saving for end user
- › **Clean handling**
Eliminates downtime
- › **No grease migration in application**
Improved performance
- › **Reduced external contamination in application**
Higher accuracy
- › **Longer grease life**
1.5 times the life of an open greased bearing

Upgrading Sealed TAC

Sealed Ball Screw Support Bearings are now available with seals for extra reliability in dusty and water/oil contaminated environments.

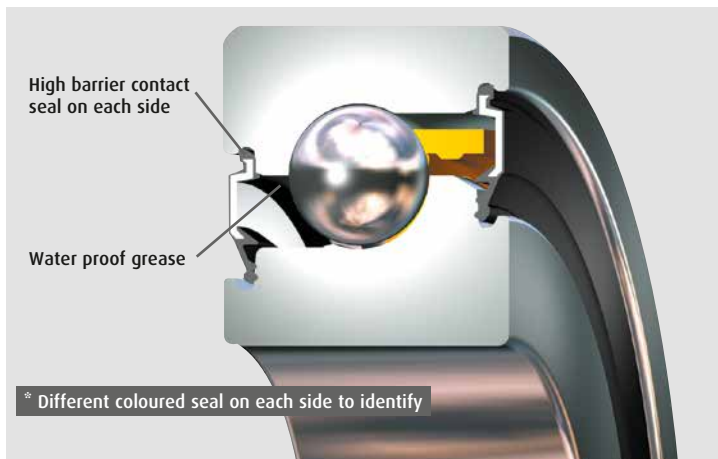

The seals are contacting type, which means that the sealing properties are excellent and each seal is a different colour to help identify the front and rear face of the bearing. A vee line is also marked on the outer ring surface for additional indication (point of vee showing front face). The grease for the sealed bearings is a special WPH waterproof type; this provides an additional barrier against water contamination.

Although these seals are contacting for additional protection, the low friction design prevents high temperature generation.

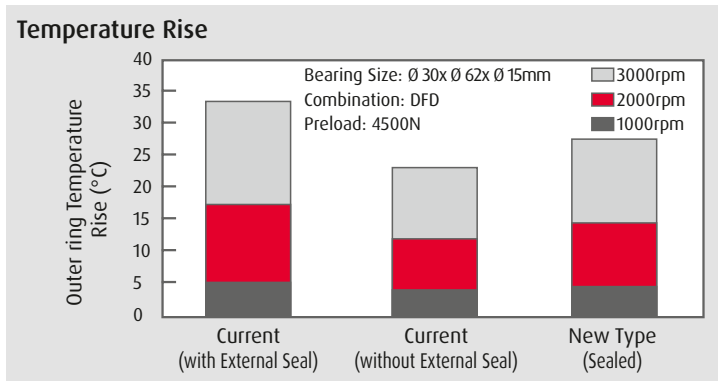

The left graph shows the advantages of this new design. Normally some type of external seal would be required to protect in wet conditions; it can be seen that the new sealed bearings run at a lower temperature than the same open type using an external sealing arrangement.

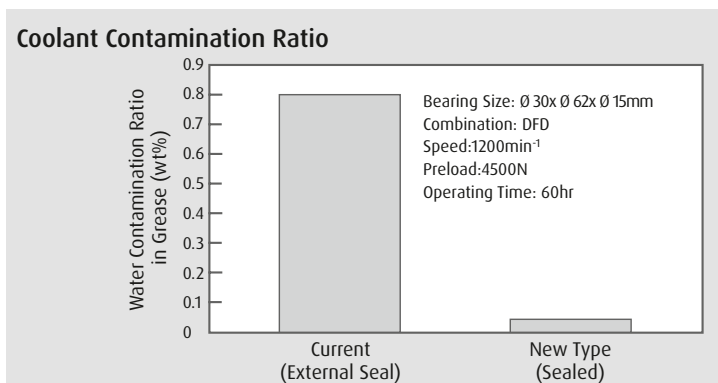

The left graph shows the effectiveness of the low friction contact seals in the ability to prevent water ingress. However the use of the seals also prevents dust and other contamination from entering the bearing during the fitting process and prevents the loss of grease from the bearings particularly in vertical ball screw applications. Reducing the grease leakage improves the life of the bearing considerably.

Upgrading Sealed TAC

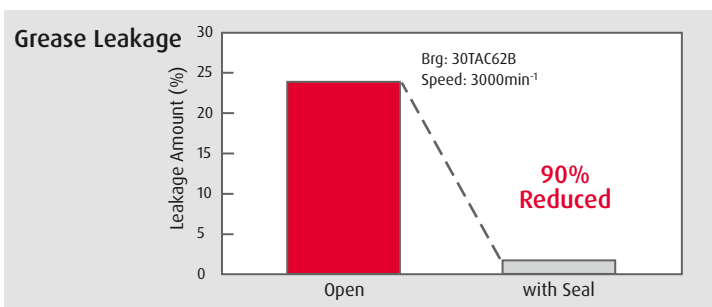

This new product is standardised for Single Universal (SU) arrangements and is available from 15mm to 45mm bore size.

Designation Example:

30TAC62BDDG**SUC10PN7B** (DDG = seal symbol)



Summary of Benefits

- › Longer life
- › Reduced grease loss
- › Low temperature compared to conventional sealing arrangements
- › Prevent water and dust ingress
- › Better handling

Upgrading Hybrid Bearings

Many machine repairers are upgrading to hybrid - (steel ringed bearings using silicon nitride ceramic balls) in order to improve reliability, particularly in situations where warranties are extending from 1 to 2 and sometimes up to 3 years.



Features of Hybrid Bearings – Lighter Weight

Due to mass being approximately 40% of steel, hybrid bearings can run up to 25% faster than conventional all steel bearings. This also means that the generated temperature is also lower.

Smoother Surface

The surface finish of the ceramic ball is much smoother than the steel ball, this improves the accuracy of rotation and the part being manufactured.

Harder and Stiffer

The ceramic ball is much harder than a conventional steel ball (HV 1700@ <800°C compared to HV 700@20°C). This means that the ceramic ball is less likely to be damaged by small amounts of hard contamination. Higher stiffness means that the hybrid bearing will distort less under high load compared to the steel ball type.

Corrosion and Electrical Resistance

These bearings can be run in more arduous environments. The electrical resistance prevents pitting of the ball surface due to electrical discharge in built-in motor spindles.

Designation System:

7014(SN24)RSULP3 (Standard Precision Product)

70BNR10(H)SULP3 (High-speed ‘Robust’ Product)

Summary of Benefits

- › Higher Speed
- › Longer Life
- › Cooler Temperature
- › Higher Accuracy
- › Higher Reliability

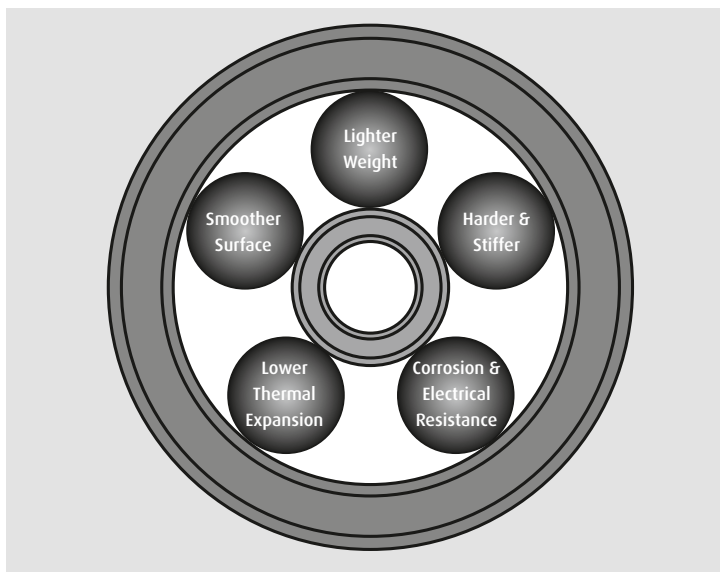

Grease Lubricated

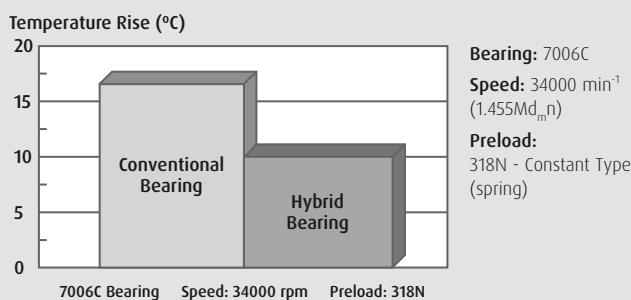

Upgrading TYN Cages

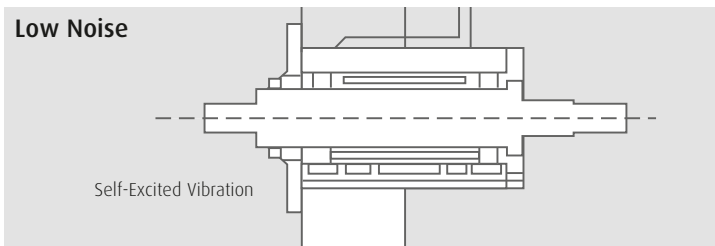

Cage	Grease		Temperature		
			Room (20°C)	0°C	-10°C
TYN	Multemp	PS2	A	A	A
	Isoflex	NBU15	A	A	A
	Isoflex	NBU8EP	A	A	A
Phenolic	Multemp	PS2	B		C
	Isoflex	NBU15	B		C
	Isoflex	NBU8EP	C		

A: No cage noise, B: cage noise often observed, C: cage noise was observed. TYN cage runs silence compared to phenolic cage

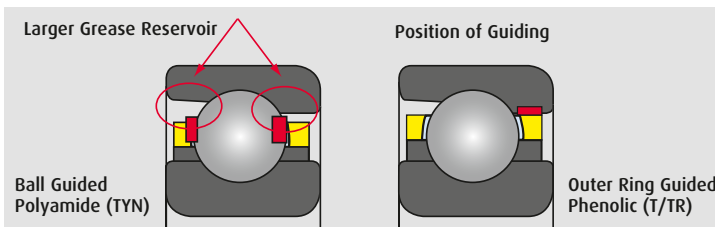

Cage Type	Bending Strength MPa	Tensile Strength MPa
T/TR	150	90
TYN	237	172

Strength measured on test piece, not complete cage

The majority of angular contact bearings use phenolic type cages and these are exceptional good for a wide range of conditions and particularly for high-speed since they are outer ring located. However, there are advantages to using TYN cages in certain applications, particularly in grease lubrication. TYN is a polyamide material and this cage is designed to be ball guided.

Reduced Cage Noise

In certain applications cage noise can occur in grease lubricated bearings. This is due to friction between the ballsurface and the cage guide surface; this can be particularly noticed in cold conditions. The TYN cage design eliminates this due to the very low friction quality of the material and good vibration absorption characteristics as well as improvements in the cage shape.

The test data left shows the comparison of the Phenolic and Polyamide cage:

Longer Grease Life – Shorter ‘Running In’ Time

Grease life is longer because there is more internal space for the grease to collect in and because the grease can clear the rotating parts more quickly, the running in time is reduced.

Cage Guiding Contact:

More grease space with TYN. Less grease pushed out of bearing, therefore, longer life. Shorter running in time compared to Phenolic and more stable temperature characteristics.

Higher Strength

The TYN material has both higher bending and tensile strength. TYN cages can be used up to a speed of $1.4M_d_n$. (Mean bearing diameter in mm X speed in rpm.) This covers most grease lubricated applications. Above $1.4M_d_n$ phenolic cage should be selected.

Examples of Designation:

7014CTYNDULP3 (Standard Precision)

70BNR10TYNDULP3 (High-Speed Precision)

Upgrading TAC Conversions

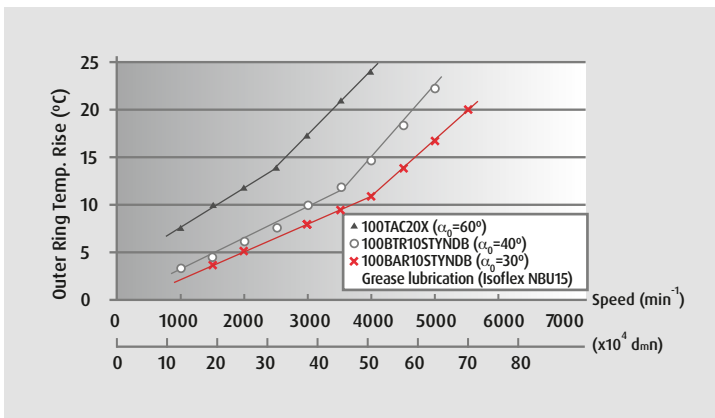

Traditionally, medium to large lathes require very good radial and axial rigidity. For this reason it is normal to use a configuration of roller bearings and thrust bearings at the front of the spindle for radial and axial rigidity respectively. The conventional type thrust bearing was a double row, bi-directional 60° contact angle TAC series bearing. This is still available for bore sizes of 140mm and above. However for lathe spindles below this size the requirements are now for higher speed and/or lower temperature performance. For this reason a new type of thrust bearing has been designed to fit this requirement.

New 'Robust' Design BAR and BTR Thrust Bearings

This new range has the same size and number of balls as the TAC series but have special internal geometry and lower contact angles (30° or 40°) enabling low heat generation, higher speed performance and good axial rigidity.

Higher Speed Performance

The new thrust bearing design can run to higher speeds, BAR (30°) being the fastest followed by BTR (40°) which has a higher rigidity compared to BAR but still runs faster than the original TAC (60°). The new thrust bearings can also be supplied in hybrid types (ceramic balls) enabling even higher speeds and rigidities.

Interchangeability

The width of the pair of new thrust bearings is special to allow easy interchange between the old TAC type bearing. The outer diameter tolerance is the same as the TAC bearings to enable a clearance fit in the housing, this ensures radial load is only taken by the adjacent roller bearing.

Example of designation:

Original 60° type: **100TAC20DPN7+LC6**

New 30° type: **100BAR10STYNDBLP4A** (S=steel, H=Hybrid)

New 40° type: **100BTR10STYNDBLP4A** (S=steel, H=Hybrid)

Relative Speed

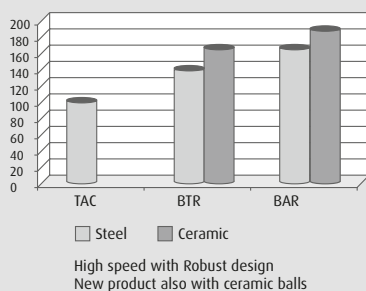

Low Heat Generation

- › ROBUST design enables low heat generation and high-speed operation.
- › Longer grease life thanks to reduced grease deterioration and TYN resin cage.
- › Better machining accuracy.

Interchangeability

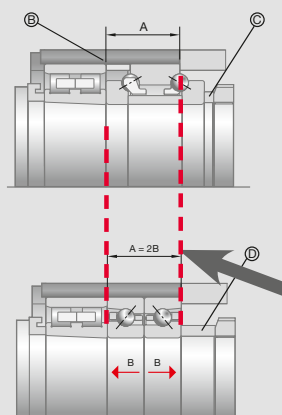

Advantages

- › Reduced components - eliminates outer spacer B
- › Easy mounting since single row bearing structure
- › Easy to upgrade from old to new design - only inner ring spacer needs to change
- › (C to D), bore and OD same as old design

Upgrading TB Cages

An exciting new material has been patented by NSK for use in roller bearings. This new material is an engineered polymer called 'PPS' Polyphenylene sulphide and is designated TB type.



Longer Life

Experiments also showed that the TB cage could be run under higher preloaded conditions and closer to boundary lubrication compared with brass cages. In endurance tests under severe conditions wear could be found in the Brass cage bearings after 200 hours compared to 300 hours for the PPS material of the TB cage.

Example of Designation:

NN3022TBKRE44CC0P4

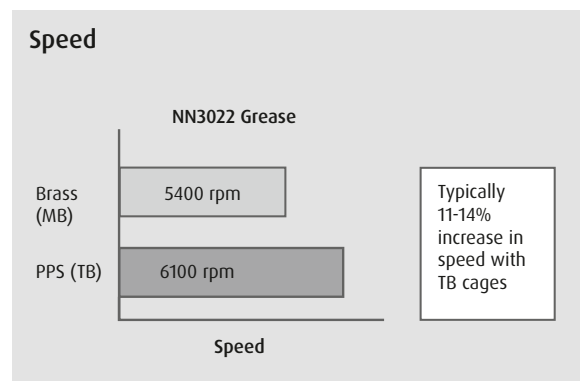
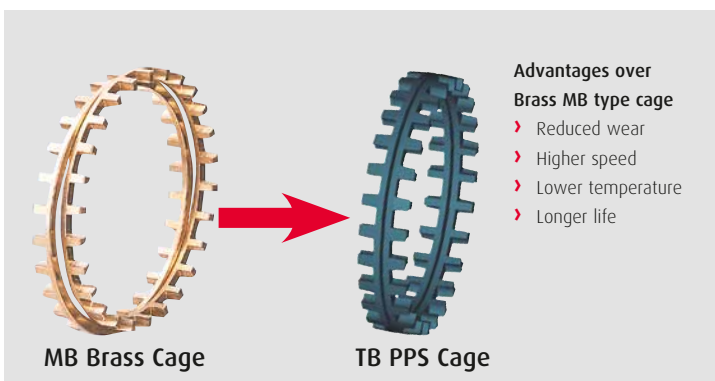

Wear Resistance

Grease discolouration due to wear on brass cage

MB cage before testing



MB cage after testing

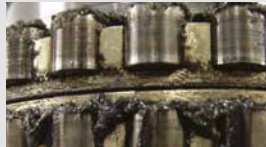

Reduced wear using TB cage

TB cage before testing

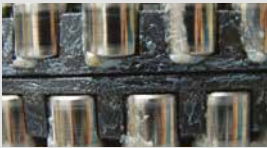

TB cage after testing



Lower Temperature

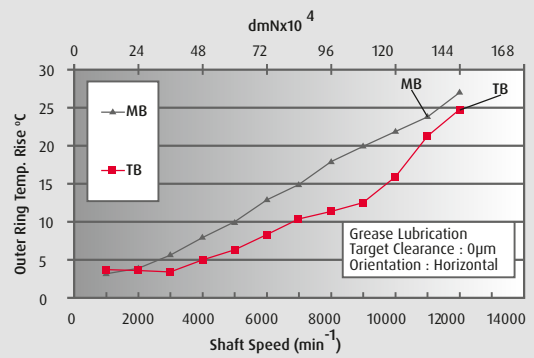

Size and Range

Bearing Type	Cage Symbol	Specification	Available Size
NN	MB	Roller guided machined brass cage	NN3920 to NN3956 NN3920 to NN3956 NN4920 to NN4940
	TB	Roller guided PPS resin cage	NN3006 to NN3024

Supplementary Information

Interchange Guide for Precision Angular Contact Bearings

(Symbols in brackets show seal designation when available; Items in red are the manufacturers identifiers of particular parameters)

Example of 25 degrees contact angle

Standard Design	ISO Series	NSK	SKF	SNFA	Fafnir	FAG
○ [○]	19	79xxA5(V1V)	719xxACD	SEBxxxxx3	3xx93xxWI	B719xxE.(2RSD)
	10	70xxA5(V1V)	70xxACD	SEBxxxxx3	3xx91xxWI	B70xxE.(2RSD)
	02	72xxA5	72xxACD	E2xxxxx3	3xx21xxWI	B72xxE.(2RSD)
● [●]	19	79xxA5SN24(V1V)	719xxACD/HC	SEBxx/NSxxx3	3xxC93xxWI	HCB719xxE.(2RSD)
	10	70xxA5SN24(V1V)	70xxACD/HC	EXxx/NSxxx3	3xxC91xxWI	HCB70xxE.(2RSD)

High-Speed Design	ISO Series	NSK	SKF	SNFA	Fafnir	FAG
○ [○]	19	xxBER19 (V1V)S	719xxACE	VEBxxxxx3	3xx93HX(VV)	HS(S)719xxE
	10	xxBER10 (V1V)S	70xxACE	VEXxx(/S)xxx3	3xx91HX(VV)	HS(S)70xxE
● [●]	19	xxBER19 (V1V)H	719xxACE/HC	VEBxx(/NS)xxx3	3xxC93HX(VV)	HC(S)719xxE
	10	xxBER10 (V1V)H	70xxACE/HC	VEXxx(/S)/NSxxx3	3xxC91HX(VV)	HC(S)70xxE
	19	xxBER19 (V1V)X	-	VEBxxXNxxx3	-	XC(S)719xxE
	10	xxBER10 (V1V)X	-	VEXxx(/S)/XNxxx3	-	XC(S)70xxE

○ Steel balls ● Ceramic balls [○] Steel balls sealed [●] Ceramic balls sealed  Special material rings/ Ceramic balls (Sealed)

Interchange Guide for Precision Thrust Bearings



Thrust Bearings for Spindle Applications Contact Angle	NSK	SKF	SNFA	Fafnir	FAG
30 degrees	xxBAR	BTMxx A/DB	-	-	-
40 degrees	xxBTR	BTMxx B/DB	-	-	-
60 degrees	xxTAC	2344xx	-	-	2344xx

Interchange Guide for Precision Ball Screw Support Bearings



Series	NSK	SKF	SNFA	Fafnir	FAG
Non-ISO Metric (30 bore, 62 OD, 15 w)	30TAC62B	BSD3062C	BS3062	MM30BS62	BSB030062
ISO Metric (30 bore, 62 OD, 16 w)	BSB2030	BSA206C	BS230	-	760230
INCH (23.838 bore, 62 OD, 15.875 w)	BSB093	BDAB634201C	-	MM9308WI2H	-

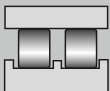
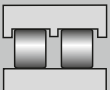

Interchange Guide for Precision Cylindrical Roller Bearings

Standard Design Construction	NSK	SKF	FAG
	NN39xx(KR)	-	-
	NN30xx(KR)	NN30xx(K)	NN30xx(K)
	NN49xx(KR)	-	-
	NNU49xx(KR)	NNU49xx(K)	NNU49xx(K)
	N10xx(KR)	N10xx(K)	N10xx(K)

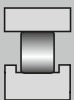
High Speed Design Construction

High Speed Design Construction (*)	NSK	SKF	FAG
 Steel Rollers and Rings	NN10xxRS(KR)	-	-
 Ceramic Rollers and Special Steel Rings	N10xxRXH(KR)	N10xxHCS(K)(*)	HCN10xx(K)
 Special Steel Rollers and Rings	N10xxRX(KR)		

(*) Normal steel rings used only

This interchange should be used as a guideline only, as manufacturers' designations may change without notice.

Supplementary Information

Bearing Failures and Countermeasures

This next section will explain the most common forms of bearing failure in a machine tool application with possible causes and countermeasures. This section includes a diagnostic chart to help the end user to quickly focus on the most important reasons for the failure.

Inspection of the dismantled bearings often reveals that the most common cause of bearing failure is contamination of either hard particles or liquid. This often causes noise and vibration and can be detected by the methods outlined at the end of this section.

Maintenance, Inspection and Correcting Irregularities

In order to maintain the original performance of a bearing for as long as possible, proper maintenance and inspection should be performed. If correct procedures are used, many bearing problems can be avoided and the reliability, productivity, and operating costs of the equipment containing the bearings are all improved. It is suggested that periodic maintenance be done following the procedure specified. This periodic maintenance encompasses the supervision of operating conditions, the supply or replacement of lubricants, and regular periodic inspection. Items that should be regularly checked during operation include bearing noise, vibration, temperature, and lubrication.

If an irregularity is found during operation, the cause should be determined and the proper corrective actions should be taken after referring to the table. If necessary, the bearing should be dismantled and examined in detail.

Bearing Failure and Countermeasures

In general, if rolling bearings are used correctly they will survive to their predicted fatigue life. However, they often fail prematurely due to avoidable mistakes. In contrast to fatigue life, this premature failure is caused by improper mounting, handling or lubrication, entry of foreign matter, or abnormal heat generation. For instance, the causes of rib scoring, as one example, are the use of improper lubricant, faulty lubricant system, entry of foreign matter, bearing mounting error, excessive deflection of the shaft or any combination of these. Thus, it is difficult to determine the real cause of some premature failures.

If all the conditions at the time of failure and previous to the time of failure are known, including the application, the operating conditions, and environment; then by studying the nature of the failure and its probable causes, the probability of similar future failures can be reduced. The most frequent types of bearing failure, along with their causes and corrective actions, are listed in the table.

The types of problems reported by end users fall into the following categories:

Reason For Return/Bearing Problem

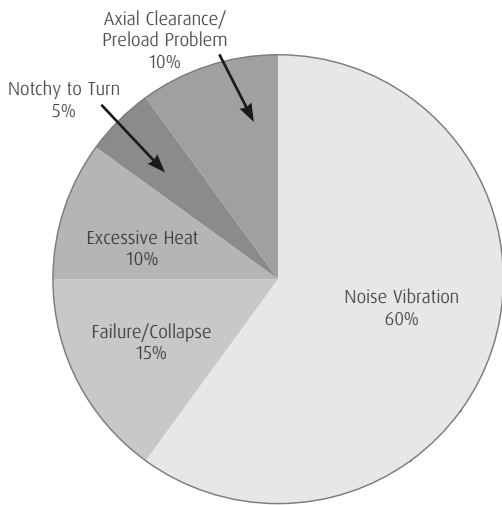



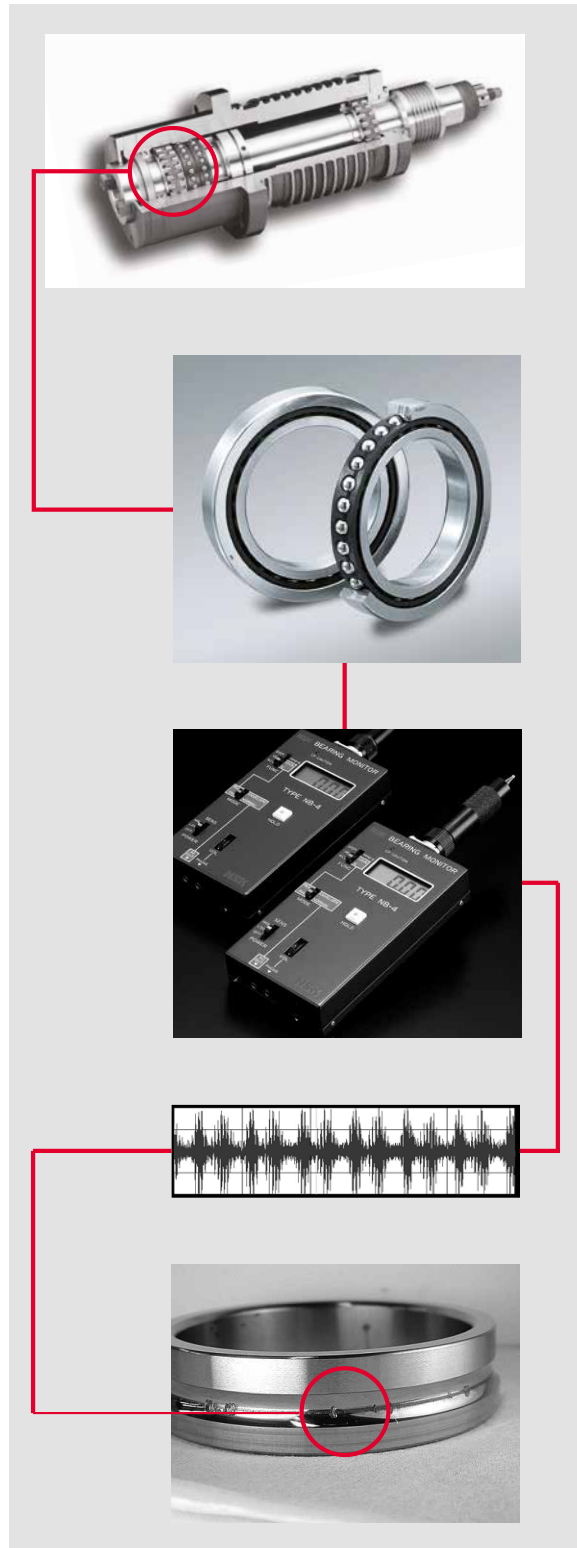
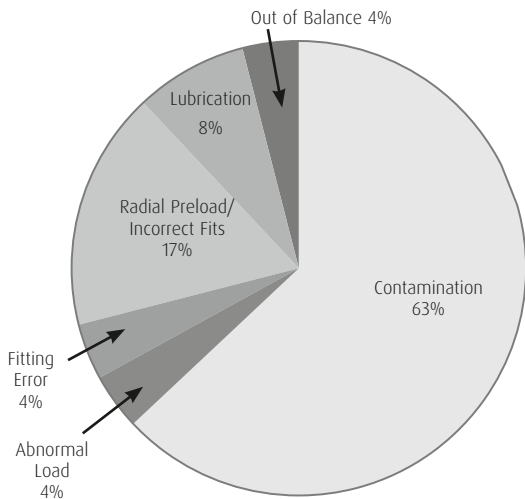





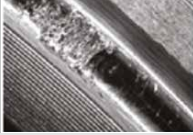

Causes of Bearing Problem











Supplementary Information

Bearing Failures and Countermeasures

Causes and Countermeasures for Bearing Failures

Type of Failure	Irregularities	Photo	Probable causes	Countermeasures
Flaking	Flaking on one side of the raceway of radial bearing.		Abnormal axial load (sliding failure of free-side bearing)	When mounting the outer ring of free-side bearings, it should be fitted loosely, to allow axial expansion of the shaft.
	Flaking pattern inclined relative to the raceway in radial ball bearings. Flaking near the edge of the raceway and rolling surface in roller bearing.		Improper mounting, bending of shaft, inadequate centering, inadequate tolerances for shaft and housing.	Use care in mounting and centering, select a bearing with a large clearance and correct the squareness of shaft and housing shoulder.
	Flaking of raceway with same spacing as rolling element.		Large shock load during mounting, rusting while bearing is out of operation for prolonged period, mounting flaws of cylindrical roller bearings	Use care in mounting and apply a rust preventative when machine operation is suspended for a long time.
	Premature flaking of raceway and rolling element.		Insufficient clearance, excessive load, improper lubrication, rust, etc.	Select proper fit, bearing clearance and lubricant.
	Premature flaking of combined bearings.		Excessive preload.	Adjust the preload.
Scoring	Scoring or smearing between raceway and rolling surface.		Inadequate initial lubrication, excessively hard grease, high acceleration when starting operation.	Use a softer grease and avoid rapid acceleration.
	Scoring or smearing between the end face of the rollers and guide rib.		Inadequate lubrication, incorrect mounting and large axial load.	Select proper lubricant and modify the mounting.
Cracks	Crack in outer or inner ring.		Excessive shock load, excessive interference in fitting, poor shaft cylindricity, improper sleeve taper, large fillet radius, development of thermal cracks and increased flaking.	Examine the loading conditions, modify the fit of bearing and sleeve, improve accuracy in machining shaft and sleeve, correct fillet radius (the fillet radius must be smaller than the bearing chamfer).
	Crack in rolling element or broken rib.		Increased flaking, shock applied to rib during mounting or dropped during handling.	Use care in mounting and handling a bearing.
	Fracture of cage.		Abnormal loading on the cage due to incorrect mounting. Improper lubrication.	Correct mounting and examine the lubrication method and lubricant.

Type of Failure	Irregularities	Photo	Probable causes	Countermeasures
Indentations	Indentation on raceway with the same spacing as rolling element (brinelling).		Shock load during mounting or excessive load when not rotating.	Use care in handling the bearing.
	Indentation on raceway and rolling elements.		Entry of foreign matter such as metallic particles and grit.	Clean the housing, improve the seals and use clean lubricant.
Abnormal wear	False brinelling (phenomenon similar to brinelling).		Vibration of the bearing without rotation when out of operation, such as during transport or rocking motion of vibration.	Secure the shaft and housing use oil as a lubricant and reduce vibration by applying preload.
	Fretting, localized wear with reddish-brown wear dust at fitting surface.		Sliding wear at a minute gap in the fitting surface.	Increase interference and apply oil.
	Wearing on raceway, rolling elements, rib and cage.		Entry of foreign matter, incorrect lubrication and rust.	Improve sealing capabilities, clean the housing and use a clean lubricant.
	Creep, scoring wear at fitting surface.		Insufficient interference, insufficiently secured sleeve.	Modify the fitting and tighten the sleeve properly.
Seizure	Discoloration and melting of raceway, rolling elements and ribs.		Insufficient clearance, incorrect lubrication, or improper mounting.	Examine the fitting and internal clearance of a bearing, supply an adequate amount of proper lubricant and examine the mounting method and quality of related parts.
Corrosion and Rust	Corrosion and rust at bearing interior or fitting surface.		Condensation of water from the air, or fretting, entry of corrosive substance (especially varnish gas).	Store carefully when in a moist or hot climate, take rust prevention measures before removing from operations for a long time, and select proper varnish and grease.

Supplementary Information

Bearing Failures and Countermeasures

Damage name	Location (phenomenon)	Typical causes											Remarks			
		Handling		Bearing surrounding			Lubrica-tion		Load			Speed		Bearing selection		
		Stock, shipping	Mouting	Shaft, housing	Sealing device, water, debris	Temperature	Lubricant	Lubricant method	Excessive load	Moment load	Too small load	High speed, high acceleration			Oscillating, vibration, stationary	
01. Flaking	Raceway, rolling surface		●	●	●		●	●	●	●					●	
02. Peeling	Raceway, rolling contact surface				●		●	●				●	●			
	Bearings outer diameter surfaces			●	●		●	●								* mating rolling part
03. Scoring	Roller end surface, rib surface		●	●	●		●	●	●	●		●				
	Cage guide surface, pocket surface		●		●		●	●								
04. Smearing	Raceway, rolling surface				●		●	●			●	●				
05. Fracture	Raceway collar, rollers	●	●	●					●	●						
06. Cracks	Raceway rings, rolling elements		●	●		●			●	●						
	Rib surface, roller end face, cage guide surface (thermal crack)			●			●	●	●							
07. Cage damage	(Deformation), (fracture)		●	●					●	●						
	(Wear)		●		●		●	●	●	●		●				
08. Denting	Raceway, rolling surface,(innumerable small dents)				●		●									
	Raceway (debris on the rolling element pitch)	●	●						●				●			
09. Pitting	Raceway, rolling surface				●		●	●								
10. Wear	Raceway, rolling surface, rib surface, roller end face		●		●		●	●								
11. Fretting	Raceway, rolling surface	●	●	●			●	●	●			●	●			
	Bearing outside and bore, side surface (Contact with housing and shaft)		●	●					●							
12. False brinelling	Raceway, rolling surface	●					●	●						●		
13. Creep	Raceway, rolling surface		●	●		●	●*	●*	●			●				* Loose fit
14. Seizure	Fitting surface		●	●	●		●	●	●	●		●		●		
15. Electrical corrosion	Raceway, rolling surface		●*	●*												* Electricity passing through the rolling element
16. Rust and corrosion	Raceway ring, rolling element, cage	●	●		●	●	●	●								
17. Mounting flaws	Raceway, rolling surface		●	●												
18. Discoloration	Raceway ring, rolling element, cage					●	●	●								

Remark: This table is not comprehensive. It lists only the more commonly occurring damages, causes, and locations.

Supplementary Information

Trouble Shooting

Sound and Vibration - Classification of Sounds and Vibrations

Sound and vibration accompany the rotation of rolling bearings. The tone and amplitude of such sound and vibration varies depending on the type of bearing, mounting conditions, operational conditions, etc. The sound and vibration of a rolling bearing can be classified under the following four chief categories listed in the table on page 76 and each category can be further classified into several sub-categories, as described in the table overleaf. Boundaries between groups are, however, not definite. Even if some types of sounds or vibrations are inherent in the bearings, the volume might be related to the manufacturing process, while some types of sounds or vibrations, even if they arise due to manufacturing, cannot be eliminated even in normal conditions.

By recording sounds and vibrations of a rotating machine and analysing them, it is possible to infer the cause. As can be seen from the charts below, a mechanically normal bearing shows a stable waveform. However, a bearing with a scratch, for example, shows a waveform with wide swings indicating large-amplitude sounds at regular intervals. NSK produces a Bearing Monitor NB-4, a vibration measuring monitor that can diagnose irregularities in a rotating machine. The causes of the irregularities can be inferred using the NB-4 and recording equipment, such as a personal computer.

Vibration Measuring Equipment, Bearing Monitor NB-4



Sound waveform of a normal bearing

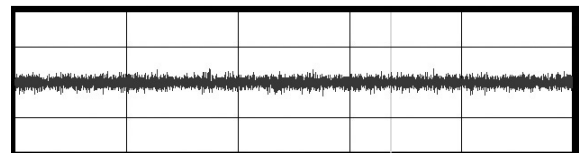

Sound waveform of a scratched bearing

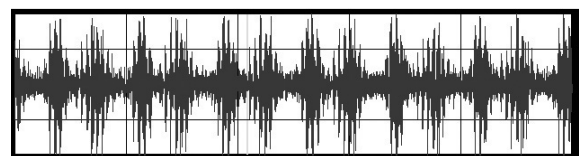

Supplementary Information

Trouble Shooting

Classification of Sounds and Vibrations in a Rolling Bearing

	Sound	Vibration		Features	
Structural	Race noise	Free vibration of raceway ring		Continuous noise, basic unavoidable noise which all bearings generate	
	Click noise	Free vibration of raceway ring, free vibration of cage		Regular noise at a certain interval, large bearings and horizontal shaft, radial load and low rpm	
	Squeal noise	Free vibration of raceway ring		Intermittent or continuous, mostly large cylindrical roller bearings, radial load, grease lubrication, at particular speed	
	Cage noise	"CK" noise	Free vibration of cage		Regular noise at a certain interval, all bearing types generate it
		"CG" noise	Vibration of cage		Intermittent or continuous, lubrication with particular grease
		Tapping noise	Free vibration of cage		Certain interval, but a little irregular under radial load and during initial stage
-	Rolling element passage vibration		Continuous, all bearing types under radial load		
Manufacturing	Waviness noise	Vibration due to waviness	Inner ring	Continuous noise	
			Outer ring	Continuous noise	
			Rolling element	Continuous with rollers, occasional with balls	
Handling	Flaw noise	Vibration due to flaw	Inner ring	Regular noise at a certain interval	
			Outer ring		
			Rolling element		
	Contamination noise	Vibration due to contamination		Irregular	
Others	Seal noise	Free vibration of a seal		Contact seal	
	Lubricant noise	-		Irregular	
	-	Runout	f_i	Continuous	
			f_c	Continuous	
			$f_i - 2f_c$	Continuous	

n: Positive integer (1, 2, 3...)
 Z: Number of rolling elements
 f_{RIN} : Ring natural frequency in radial bending mode, Hz
 f_{MI} : Natural frequency in the mode of angular vibration in inertia of outer ring-spring system, Hz
 f_i : Rotation frequency of inner ring, Hz

Generated frequency (frequency analysis)			Source	Countermeasures
FFT of original wave		FFT after envelope (basic No.)		
Radial (angular) direction	Axial direction			
f_{RIN}, f_{MI}	f_{AIN}, f_{AM}	-	Selective resonance of waviness (rolling friction)	Improve rigidity around the bearings, appropriate radial clearance, high-viscosity lubricant, high-quality bearings
f_{RIN}, f_{MI}	f_{AIN}, f_{AM}	$2f_c$	Collision of rolling elements with inner ring or cage	Reduce radial clearance, apply preload, high-viscosity oil
($\approx f_i, 2N, f_i, 3N$)	-	-	Self-induced vibration caused by sliding friction at rolling surface	Reduce radial clearance, apply preload, change the grease, replace with countermeasured bearings
Natural frequency of cage		f_c	Collision of cage with rolling elements or rings	Apply preload, high-viscosity lubricant, reduce mounting error
Natural frequency of cage		-	Self-induced vibration caused by friction at cage guide surface	Change of grease brand, replace with countermeasured cage
Natural frequency of cage		$2f_c$	Collision of cage and rolling element caused by grease resistance	Reduce radial clearance, apply preload, low-viscosity lubricant
$2f_c$	-	-	Displacement of inner ring due to rolling element passage	Reduce radial clearance, apply preload
$nZf_i \pm f_i$ ($nZ \pm 1$ peaks)	nZf_i (nZ peaks)	-	Inner ring raceway waviness, irregularity of shaft exterior	High-quality bearings, improve shaft accuracy
nZf_c ($nZ \pm 1$ peaks)	nZf_c (nZ peaks)	-	Outer ring raceway waviness, irregular bore of housing	High-quality bearings, improve housing bore accuracy
$2nf_b \pm fc$ ($2n$ peaks)	$2nf_b$ ($2n$ peaks)	-	Rolling element waviness	High-quality bearings
f_{RIN}, f_{MI}	f_{AIN}, f_{AM}	$2f_i$	Nicks, dents, rust, flaking on inner ring raceway	Replacement and careful bearing handling
		$2f_c$	Nicks, dents, rust, flaking on inner ring raceway	Replacement and careful bearing handling
		$2f_b$	Nicks, dents, rust, flaking on rolling elements	Replacement and careful bearing handling
f_{RIN}, f_{MI}	f_{AIN}, f_{AM}	Irregular	Entry of dirt and debris	Washing, improve sealing
Natural frequency of seal		(f_i)	Self-induced vibration due to friction at seal contact area	Change the seal, change the grease
-	-	Irregular	Lubricant or lubricant bubbles crushed between rolling elements and raceways	Change the grease
f_i	-	-	Irregular inner ring cross-section	High-quality bearings
f_c	-	-	Ball variation in bearing, rolling elements non-equidistant	High-quality bearings
$f_i - 2f_c$	-	-	Non-linear vibration due to rigid variation by ball variation	High-quality bearings

f_c : Orbital revolution frequency of rolling elements, Hz
 f_{AIN} : Ring natural frequency in axial bending mode, Hz
 f_{AM} : Natural frequency in the mode of axial vibration in mass of outer ring-spring system, Hz
 f_i : $f_i = f_r - f_c$, Hz
 f_b : Rotation frequency of rolling element around its centre, Hz

Supplementary Information

Bearing Preload Conversion Tables – Standard Angular Contact

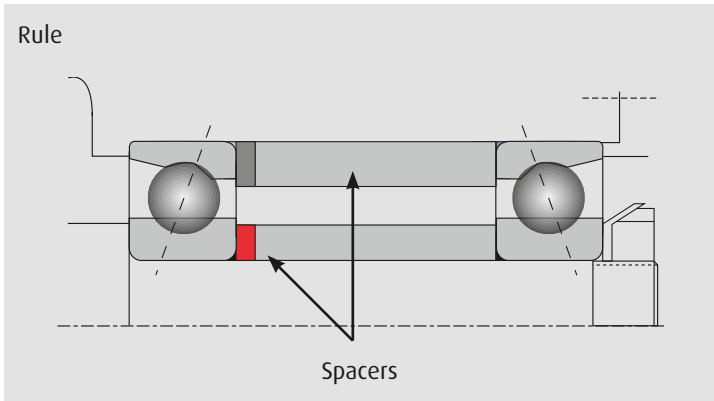

To increase preload: reduce inner ring spacer
To reduce preload: reduce outer ring spacer



Preload Conversion Tables

In cases of emergency it is possible to change the preload of a set of bearings, providing a spacer is used between the opposing preloading bearings. The tables on pages 79 – 83 show the amount of spacer length adjustment required to change from one preload to another.

For example, if the preload of a 7914 15° contact bearing needed to be changed from extra light to light, the inner ring spacer length would need to be reduced by 6µm. From medium to heavy would be 13µm reduction of inner ring spacer length. If it was required to change from light to heavy, it would be necessary to accumulate the values i.e. 12 and 13 to equal 25µm inner ring spacer length reduction.

In example when reducing the preload, select the same values from the table below but reduce the length of the outer spacer.

Standard Series Series 79

Bearing number	15° contact angle preload			25° contact angle preload		
	Extra light to light µm	Light to to medium µm	Medium to to heavy µm	Extra light to light µm	Light to to medium µm	Medium to to heavy µm
7900	3	3	5	1	4	3
7901	2	5	5	2	2	4
7902	3	4	7	2	3	5
7903	3	5	7	2	3	4
7904	4	5	7	3	3	6
7905	3	7	8	2	4	5
7906	3	6	7	2	3	5
7907	4	7	9	3	5	7
7908	4	9	10	2	6	7
7909	5	7	9	3	6	7
7910	4	10	10	3	6	8
7911	5	9	11	3	6	7
7912	4	9	11	3	5	8
7913	5	9	11	3	6	7
7914	6	12	13	4	7	10
7915	6	11	14	4	8	9
7916	5	12	13	4	7	10
7917	7	12	16	4	8	12
7918	6	14	16	4	8	11
7919	6	15	16	5	9	11
7920	8	14	19	5	9	12
7921	8	14	18	5	10	13
7922	8	14	18	5	10	13
7924	9	18	21	6	11	15
7926	10	18	23	7	11	16
7928	9	18	23	6	13	16
7930	11	20	25	7	14	19
7932	11	20	25	7	15	18
7934	11	20	25	7	14	19
7936	13	23	30	9	16	22
7938	13	24	30	9	16	22
7940	15	27	34	10	19	25

Supplementary Information

Bearing Preload Conversion Tables – Standard Angular Contact

Standard Series

Series 70

Bearing number	15° contact angle preload			25° contact angle preload			30° contact angle preload		
	Extra light to light µm	Light to medium µm	Medium to heavy µm	Extra light to light µm	Light to medium µm	Medium to heavy µm	Extra light to light µm	Light to medium µm	Medium to heavy µm
7000	3	5	7	3	3	5	5	5	5
7001	3	6	8	3	4	6	5	5	5
7002	4	6	9	2	5	5	5	5	5
7003	3	6	9	2	5	6	5	5	5
7004	4	8	10	3	6	7	5	5	5
7005	4	9	10	3	4	7	5	5	5
7006	4	10	11	3	6	8	5	5	5
7007	6	9	12	4	7	9	5	5	5
7008	5	11	13	4	6	9	5	5	5
7009	5	11	14	4	7	9	5	5	10
7010	6	12	14	4	7	10	5	5	10
7011	7	13	16	5	9	11	5	10	5
7012	7	15	16	5	8	11	5	10	5
7013	7	11	15	4	9	11	5	10	5
7014	7	16	18	5	9	13	5	11	9
7015	7	17	18	5	10	13	5	10	10
7016	8	17	21	5	12	14	10	10	10
7017	8	18	20	5	11	14	10	10	10
7018	10	19	23	6	12	16	10	15	10
7019	10	17	22	6	12	17	10	15	10
7020	9	19	23	6	13	16	10	15	10
7021	10	21	25	7	13	18	10	15	10
7022	12	24	29	8	15	20	15	15	15
7024	12	24	29	8	15	21	15	15	15
7026	13	25	31	8	16	22	15	20	15
7028	13	23	30	9	17	21	15	20	15
7030	14	25	32	9	17	24	15	22	23
7032	15	28	33	10	18	25	15	20	22
7034	17	31	38	11	22	28	20	17	23
7036	18	32	40	12	22	30	24	16	24
7038	19	34	43	12	24	32	25	18	26
7040	20	36	45	13	25	34	30	30	35

Standard Series

Series 72

Bearing number	15° contact angle preload			25° contact angle preload			30° contact angle preload		
	Extra light to light μm	Light to medium μm	Medium to heavy μm	Extra light to light μm	Light to medium μm	Medium to heavy μm	Extra light to light μm	Light to medium μm	Medium to heavy μm
7200	4	7	10	3	5	6	5	5	-
7201	4	9	10	2	6	7	5	5	5
7202	4	8	10	3	7	8	5	5	5
7203	4	12	12	3	7	7	10	5	5
7204	5	13	13	3	8	10	10	5	5
7205	5	11	11	3	7	10	10	5	5
7206	7	12	15	4	8	10	10	5	5
7207	7	15	18	4	10	12	10	5	10
7208	8	16	18	5	11	13	10	5	11
7209	9	14	19	5	12	15	10	10	10
7210	8	16	19	5	12	14	10	10	10
7211	9	21	22	6	13	16	10	16	9
7212	11	20	25	7	14	18	10	15	10
7213	11	21	26	6	15	18	10	15	10
7214	11	23	26	7	15	19	15	15	10
7215	11	21	26	7	15	19	15	15	10
7216	12	23	29	8	16	21	15	15	10
7217	13	26	32	9	16	22	16	19	15
7218	14	28	33	9	18	25	20	20	10
7219	15	30	36	10	19	26	15	20	15
7220	16	32	39	11	20	28	15	25	15
7221	17	35	41	12	21	29	20	20	20
7222	19	35	43	13	22	31	20	25	20
7224	19	35	43	13	24	33	20	30	15
7226	19	34	43	13	24	31	25	30	15
7228	21	37	49	14	26	35	31	29	15
7230	23	41	53	15	28	40	30	31	15

Supplementary Information

Bearing Preload Conversion Tables – Robust Series

Robust Series

BNR19S			BER19S		BNR19H,X,XE			BER19H,X,XE	
Bore size	18° contact angle preload		25° contact angle preload		Bore size	18° contact angle preload		25° contact angle preload	
	Extra light to light μm	Light to medium μm	Extra light to light μm	Light to medium μm		Extra light to light μm	Light to medium μm	Extra light to light μm	Light to medium μm
25	8	8	8	6	25	8	7	8	6
30	8	7	8	6	30	8	7	8	6
35	8	9	8	7	35	8	8	8	7
40	8	8	8	7	40	8	9	8	7
45	8	8	8	7	45	8	8	8	7
50	8	8	8	7	50	8	8	8	7
55	8	8	8	7	55	8	7	8	7
60	8	8	8	7	60	8	8	8	6
65	8	8	8	7	65	8	8	8	6
70	8	8	8	7	70	8	8	8	7
75	8	11	8	7	75	8	11	8	7
80	8	11	8	7	80	8	11	8	7
85	8	16	8	11	85	8	16	8	11
90	8	13	8	9	90	8	13	8	9
95	8	14	8	9	95	8	14	8	9
100	10	16	10	10	100	10	16	10	10
105	10	16	10	10	105	10	16	10	10
110	12	14	10	10	110	12	14	10	10
120	12	21	12	14	120	12	21	12	14
130	20	15	16	11	130	20	15	16	11
140	20	16	16	11	140	20	16	16	11
150	20	18	17	13	150	20	18	17	13

Robust Series



Bore size	BNR10S		BNR10S	
	18° contact angle preload		25° contact angle preload	
	Extra light to light μm	Light to medium μm	Extra light to light μm	Light to medium μm
30	5	8	8	7
35	5	7	8	7
40	5	6	8	7
45	5	6	8	7
50	5	7	8	7
55	5	8	10	8
60	5	10	10	8
65	5	10	10	8
70	10	10	10	8
75	10	10	12	9
80	10	9	12	10
85	10	9	12	10
90	10	14	12	10
95	10	14	12	10
100	10	14	12	10
105	12	15	15	11
110	15	14	15	11
120	15	14	15	11
130	20	16	16	11
140	15	15	13	10
150	18	17	15	13
150	20	18	17	13

Bore size	BNR10H,X,XE		BER10H,X,XE	
	18° contact angle preload		25° contact angle preload	
	Extra light to light μm	Light to medium μm	Extra light to light μm	Light to medium μm
30	5	6	8	7
35	5	7	8	7
40	5	6	8	7
45	5	6	8	6
50	5	7	8	6
55	5	8	10	8
60	5	10	10	8
65	5	10	10	7
70	10	10	10	7
75	10	10	12	9
80	10	9	12	9
85	10	9	12	9
90	10	14	12	9
95	10	14	12	9
100	10	14	12	9
105	12	16	15	11
110	15	14	15	11
120	15	14	15	11
130	20	16	16	11
140	15	15	13	10
150	18	17	15	13
150	20	18	17	13

Supplementary Information

Bore and OD Matching Chart

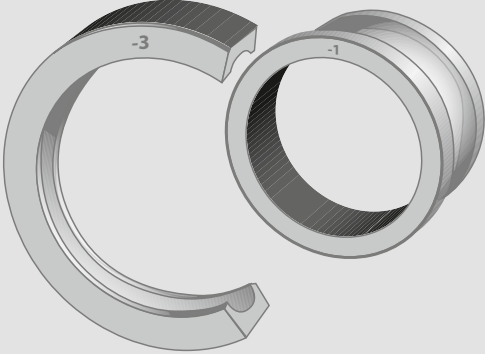
Ring size deviations are shown on both the bearing rings and box label as below.

d	-3f	-1
D	-1B	-1
C	-37	

Labels on the box: OD grade (5), Bore grade (-1)

When selecting SU bearings or mixing sets of bearings to form a new or different arrangement, it is important to ensure that the bore and OD deviations are within a certain value. If the NSK sliding chart is not available, the tables shown can be used to select the maximum difference between each deviation within the set.

Depending upon the bearing size and class of precision the maximum values for optimum load sharing with the set of bearings is shown for both the bore and independently for the OD of the bearings. The bores of the bearings to be matched together into sets are selected independently to the outer ring diameters.

NSK Super Precision Ball Bearings



79⁰⁰	79
Permissible difference of OD in a matched set (µm)	P2
	P3
	P4
Permissible difference of bore in a matched set (µm)	P2
	P3
	P4

The bearings are graded with the deviation in microns from the nominal size.

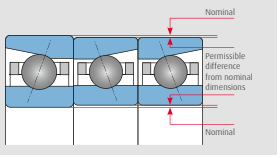

70⁰⁰	70
Permissible difference of OD in a matched set (µm)	P2
	P3
	P4
Permissible difference of bore in a matched set (µm)	P2
	P3
	P4

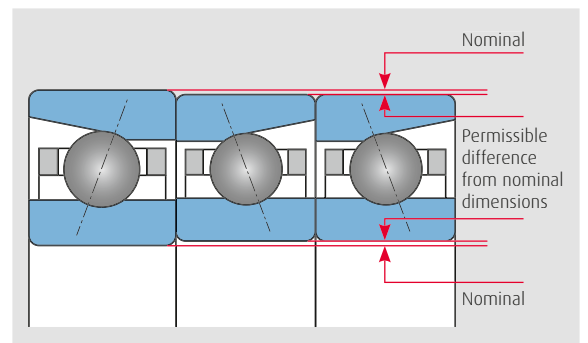

Bore & OD matching chart



72⁰⁰	72
Permissible difference of OD in a matched set (µm)	P2
	P3
	P4
Permissible difference of bore in a matched set (µm)	P2
	P3
	P4

Universal bearing matching
Super Precision ball bearings are made in accordance with the international Standards Organisation's dimension plans. All bearings in a set must be within permissible bore & OD deviation from nominal dimensions. This improves load sharing when bearings are mounted closely.

73⁰⁰	73
Permissible difference of OD in a matched set (µm)	P2
	P3
	P4
Permissible difference of bore in a matched set (µm)	P2
	P3
	P4

The size difference of the OD and bore of sets of bearings is generally less than 1/3 of the size deviation. This chart can be used to identify the permissible difference between OD's and bores in a set of bearings for precision grades for P2, P3 and P4.

› For convenience ask NSK or your distributor to supply the handy sliding chart which will enable fast and accurate matching of all bearings within the NSK range. This is a double sided pocket sized plastic coated chart.

Bore and OD Matching Chart

	P2		P3/P4	
	OD	Bore	OD	Bore
7900	2	1	2	2
7901	2	1	2	2
7902	2	1	2	2
7903	2	1	2	2
7904	2	1	2	2
7905	2	1	2	2
7906	2	1	2	2
7907	2	1	2	2
7908	2	1	2	2
7909	2	1	2	2
7910	2	1	2	2
7911	2	2	2	2
7912	2	2	2	2
7913	2	2	2	2
7914	2	2	2	2
7915	2	2	2	2
7916	2	2	2	2
7917	2	2	2	2
7918	2	2	3	2
7919	2	2	3	2
7920	2	2	3	2
7921	2	2	3	2
7922	2	2	3	2
7924	2	2	3	2
7926	2	2	3	3
7928	2	2	3	3
7930	2	2	3	3
7932	2	2	3	3
7934	2	2	3	3
7936	2	2	3	3
7938	4	2	7	4
7940	4	2	7	4
7942	4	2	7	4
7944	4	2	7	4
7948	5	2	8	4
7952	-	-	8	7
7956	-	-	8	7

	P2		P3/P4	
	OD	Bore	OD	Bore
7000	2	1	2	2
7001	2	1	2	2
7002	2	1	2	2
7003	2	1	2	2
7004	2	1	2	2
7005	2	1	2	2
7006	2	1	2	2
7007	2	1	2	2
7008	2	1	2	2
7009	2	1	2	2
7010	2	1	2	2
7011	2	2	2	2
7012	2	2	2	2
7013	2	2	2	2
7014	2	2	2	2
7015	2	2	2	2
7016	2	2	3	2
7017	2	2	3	2
7018	2	2	3	2
7019	2	2	3	2
7020	2	2	3	2
7021	2	2	3	2
7022	2	2	3	2
7024	2	2	3	2
7026	2	2	3	3
7028	2	2	3	3
7030	2	2	3	3
7032	2	2	3	3
7034	4	2	7	3
7036	4	2	7	3
7038	4	2	7	4
7040	4	2	7	4

Supplementary Information

Bore and OD Matching Chart

Bore and OD Matching Chart

	P2		P3/P4	
	OD	Bore	OD	Bore
7200	2	1	2	2
7201	2	1	2	2
7202	2	1	2	2
7203	2	1	2	2
7204	2	1	2	2
7205	2	1	2	2
7206	2	1	2	2
7207	2	1	2	2
7208	2	1	2	2
7209	2	1	2	2
7210	2	1	2	2
7211	2	2	2	2
7212	2	2	2	2
7213	2	2	2	2
7214	2	2	3	2
7215	2	2	3	2
7216	2	2	3	2
7217	2	2	3	2
7218	2	2	3	2
7219	2	2	3	2
7220	2	2	3	2
7221	2	2	3	2
7222	2	2	3	2
7224	2	2	3	2
7226	2	2	3	3
7228	2	2	3	3
7230	4	2	7	3

	P2		P3/P4	
	OD	Bore	OD	Bore
	-	-	-	-
	-	-	-	-
	-	-	-	-
7303	2	1	2	2
7304	2	1	2	2
7305	2	1	2	2
7306	2	1	2	2
7307	2	1	2	2
7308	2	1	2	2
7309	2	1	2	2
7310	2	1	2	2
7311	2	2	2	2
7312	2	2	3	2
7313	2	2	3	2
7314	2	2	3	2
7315	2	2	3	2
7316	2	2	3	2
7317	2	2	3	2
7318	2	2	3	2
7319	2	2	3	2
7320	2	2	3	2

Useful Tips

Useful Tips

List of Tips in This Publication

Tip number	Tip description	Section	Page number
1	Setting bearing high points	Bearing Selection	13
2	P3 precision more cost effective	Bearing Selection	17
3	Changing preload in spaced bearings	Bearing Selection	21
4	Greasing precision bearing using syringe	Pre-mounting	28
5	Measurement of components - room temperature	Pre-mounting	30
6	Hot air gun for heating housings	Mounting	32
7	Adjusting spindle assemblies for better runout accuracy	Mounting	35
8	Cylindrical roller bearing-housing assembly	Mounting	37
9	Simple guide for roller bearing preload calculation	Mounting	41
10	Spacer method for tapered bore cylindrical roller bearing preload setting	Mounting	43
11	'Running in' safety checks	Post-mounting	51

Index

A		E	
Axial Stiffness	12, 18, 47	End Cover Gap/Clearance	34-35
Axial Clearance	17, 22	EP Steel	56
Assembly Procedures	32	F	
Alignment	48	F and B Mark on the Bearing Box	11
B		Face to Face Arrangements	14
Bearing Overview	6	Fitting Area	24
Ball Screw Support Bearings	7	Bearing Fitting	30-31
Bending Stiffness	12	Failure, Causes of Failures, Countermeasures	68-72
Built-in Motors	13	G	
Back to Back Arrangements	14	Grease Lubrication	25
Bearing Combinations	18	Grease Quantity	26-27
Bearing Capacity	18	Gauge Method for Mounting Cylindrical Roller Bearings	40-41
Bearing Rigidity	18-19	H	
Bearing Matching Chart	22, 83-84	High-Speed Bearings	6
Bearing Tolerances	22	High Point Marking	11
Balancing	48	Handling Bearings	24
Box Bar Code	22	Housing Measurements	28
C		Induction Heater	31
Conventional Bearings	6	Hybrid Bearings	61
Cylindrical Roller Bearings	7	I	
C mark on Bearing and Box	11	Introduction	4-5
Contact Angle	12	Identification Marks	11
Constant Preload	16	Interchange Guide	66
CA Values	17	L	
C_r Values	18	Life Ratio - Cylindrical Bearings	21
C_{or} Values	18	Locknut Torque	32
Contamination	24	M	
Cleanliness	25	Material Upgrades	56
Component Checks	28	N	
Calculation Method for Preload of Cylindrical Bearings	33-39	Natural Frequency	47
Couplings	48	Noise, Cause of	51
Ceramic Balls	61		
Cage Material	62		
D			
d and D Marks on Bearing and Box	11		
$d_{m,n}$ Factor	17		
DU Arrangements	22		
DUD Arrangements	22		
Dismantling Area	24		

P		T	
Product Range	8-9	Thrust Angular Contact Bearings	7
Precision Grades	15	Tandem Arrangements	14
Preload	16-21	Tolerances	15, 22
Position Preload	16	Taper (Cylindrical Roller Bearing)	33
Preload Adjustment - AC Bearings	18	Temperature, Cause of	50
Preload Adjustment - Cylindrical Bearings	20	TB Cage	64
Packaging	25	TYN Cage	62
Press Fits	31	TAC Thrust Bearing Conversion	63
Preload Checking	46-47	Thrust Bearings	63
Preload Conversion	76-81	Trouble Shooting	73-75
Q		U	
QU Arrangements	22	Universal Bearing Sets	14
R		Upgrading	52-53
Robust Bearings	6, 54-55	Useful Tips	85
Radial Stiffness	12, 18	V	
Runouts	15	Vee Lining - Single Bearing	11
Radial Internal Clearance (RIC)	20	Vee Lining - Sets of Bearings	11
Retaining Cover Tightening	34	Vee Drives	48
Running In Process	49	X	
S		X Type Bearing	54
Serial Number	11	Z	
Single Micron Grading	15	Z Steel	56
Spring Preload	16		
Speed Factors	16		
Spindle Arrangements	14		
Sliding Chart	22		
Spacers	28		
Shaft Measurements	28		
Spindle Checks	32		
Spindle Examples	42-45		
Start Up Checks	50		
SHX Material	56		
Sealed Bearings	57-58		

NSK Sales Offices – Europe & Middle East

UK

NSK UK Ltd.
Northern Road, Newark
Nottinghamshire NG24 2JF
Tel. +44 (0) 1636 605123
Fax +44 (0) 1636 643276
info-uk@nsk.com

Middle East

NSK Bearings Gulf Trading Co.
JAFZA View 19, Floor 24 Office 2/3
Jebel Ali Downtown,
PO Box 262163
Dubai, UAE
Tel. +44 7740633888
info-me@nsk.com

South Africa

NSK South Africa (Pty) Ltd.
27 Galaxy Avenue
Linbro Business Park
Sandton 2146
Tel. +27 (011) 458 3600
Fax +27 (011) 458 3608
nsk-sa@nsk.com

France

NSK France S.A.S.
Quartier de l'Europe
2, rue Georges Guynemer
78283 Guyancourt Cedex
Tel. +33 (0) 1 30573939
Fax +33 (0) 1 30570001
info-fr@nsk.com

Nordic Sales Office

NSK Europe Norwegian Branch NUF
Østre Kullerød 5
N-3241 Sandefjord
Tel. +47 33 293160
Fax +47 33 429002
info-n@nsk.com

Spain

NSK Spain, S.A.
C/ Tarragona, 161 Cuerpo Bajo
2ª Planta, 08014 Barcelona
Tel. +34 93 2892763
Fax +34 93 4335776
info-es@nsk.com

Germany

NSK Deutschland GmbH
Harkortstraße 15
40880 Ratingen
Tel. +49 (0) 2102 4810
Fax +49 (0) 2102 4812290
info-de@nsk.com

Poland & CEE

NSK Polska Sp. z o.o.
Warsaw Branch
Ul. Migdałowa 4/73
02-796 Warszawa
Tel. +48 22 645 15 25
Fax +48 22 645 15 29
info-pl@nsk.com

Sweden

NSK Sweden Office
Karolinen Företagscenter
Växnäsgratan 10
SE-65340 Karlstad
Tel. +46 5410 3545
Fax +46 5410 3544
info-de@nsk.com

Italy

NSK Italia S.p.A.
Via Garibaldi, 215
20024 Garbagnate
Milanese (MI)
Tel. +39 02 995 191
Fax +39 02 990 25 778
info-it@nsk.com

Russia

NSK Polska Sp. z o.o.
Russian Branch
Office I 703, Bldg 29,
18th Line of Vasilievskiy Ostrov,
Saint-Petersburg, 199178
info-ru@nsk.com

Turkey

NSK Rulmanları Orta Doğu Tic. Ltd. Şti
19 Mayıs Mah. Atatürk Cad.
Ulya Engin İş Merkezi No: 68/3 Kat. 6
P.K.: 34736 - Kozyatağı - İstanbul
Tel. +90 216 4777111
Fax +90 216 4777174
turkey@nsk.com

Please also visit our website: www.nskeurope.com
Global NSK: www.nsk.com

