



KD459.51

Assembly/disassembly recommendations

<p>CITROEN: Berlingo (M49 and M59), Dispatch, Jumpy, Xsara FL, Xsara Picasso, C4.</p> <p>FIAT: Scudo, Ulysse (U6)</p> <p>LANCIA: Zeta</p> <p>PEUGEOT: 206, 307, 307 Restyling, 406 FL, 607 (I and FL), Expert Partner (M49 and M59), Ranch (M49, M59F/U)</p>	<p>ENGINES</p> <p>2.0 HDi, 2.0 JTD</p>	<p>OE reference</p> <p>0831-V3 9467628980</p>
--	---	--

TIMING BELT ARRANGEMENT OF KIT KD459.51

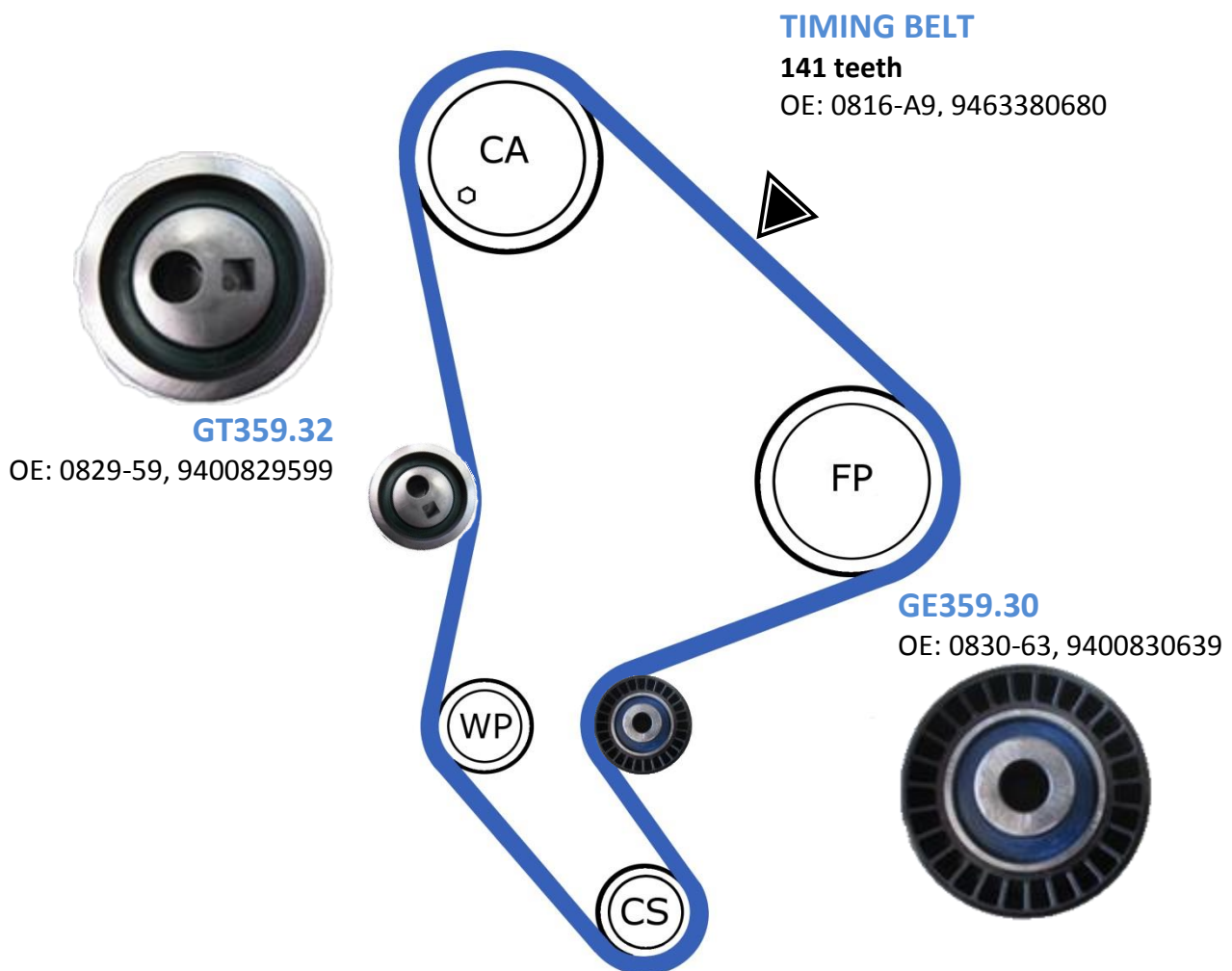

COMMON PROBLEMS WITH TENSIONER GT359.32

TIMING BELT MISALIGNMENT AND EVENTUAL CATASTROPHIC ENGINE FAILURE

Probable cause

Incorrect installation of the tensioner roller.

This failure is characteristic of a misaligned tensioner roller; the misalignment causes the timing belt to rub against the plastic engine covers.

When tightening the M8 bolt (torque = 25 Nm \pm 2 Nm), the tensioner roller **GT359.32** becomes incorrectly positioned on the guide, under the load of the belt the tensioner becomes off-centered. Fixed in place by the M8 bolt, the roller's **inner ring** comes into contact with a section of the tensioner guide. This misalignment causes the bore of the hole in the metal housing (**no. 1**) topeen over and damage the guide shaft supporting the tensioner roller (**no. 2**).

This misalignment of the tensioner could lead to a catastrophic engine failure.

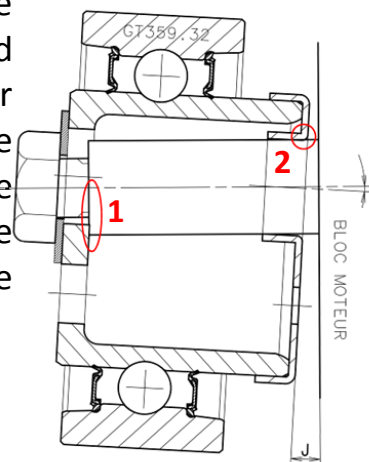

Check that the tensioner is correctly seated on the engine block and that the roller is sitting straight on the retaining bolt before the final tightening torque is applied

REPLACEMENT

Special tools

- Engine flywheel locking tool: OE (0188-Y)
- Camshaft locking pin(s): OE (0188-M)
- Retaining clip : OE (0188-K)
- Engine flywheel locking tool: OE (0188-F)
- Extractor: OE (0188-P)
- Timing belt tension gauge: OE (0192)
- Tensioning lever: OE (0188-J2)
- Chain: OE (0102-M)
- Engine bracket: OE (0102-D)
- Wrench: OE (0117-EZ)
- Plug: OE (0188-T)

Safety precautions

- Only turn the engine by means of the crankshaft pulley in the direction of operation
- Do not rotate the crankshaft or the camshafts while the timing belt is removed.
- The timing belt must not come in contact with oil or coolant.
- Make all timing belt adjustments while the engine is cold.

Tightening torques

- Bolts – engine retaining bracket: **(no. 4) 50 Nm ; (no. 5) 35 Nm**
- Brackets – engine mount **(no. 8): 22 Nm**
- Bearing **(no. 9): 32 Nm**
- Nut – engine bracket **(no. 14): 45 Nm**
- Bolts – engine bracket **(no. 15): 45 Nm**
- Bolt – tensioner roller **(no. 17): 23 Nm**; from DAM 09066 **25 ± 2 Nm**
- Bolts – camshaft gear **(no. 19):** hub **43 Nm**; gear **20 Nm**;
vacuum pump **20 Nm**
- Bolt – crankshaft pulley: stage 01: **40 Nm**; from DAM 09066 **25 ± 70 Nm**
stage 02: 51°, from DAM 09066 **60±5°**
stage 03: **195 Nm**

REMOVAL

- 1) Disconnect the earth cable from the battery.
- 2) Raise the vehicle
- 3) Remove the right front wheel
- 4) Remove the right front wheel well trim
- 5) Remove the accessories belt

- 6) Remove the air filter/ turbo ducts
- 7) Remove the protective cover from the engine flywheel (no. 1)
- 8) Install the engine flywheel locking tool (no. 2)
- 9) Unscrew the crankshaft pulley bolt
- 10) Remove the crankshaft pulley
- 11) Screw the crankshaft pulley bolt back in to place
- 12) Remove the locking tool from the engine flywheel (no. 2)
- 13) Unscrew the engine retaining bracket bolts (nos. 4 and 5)
- 14) Remove the engine retaining bracket (no. 3)
- 15) Turn the engine to lock it in place
- 16) Install the engine flywheel locking tool (no. 6)

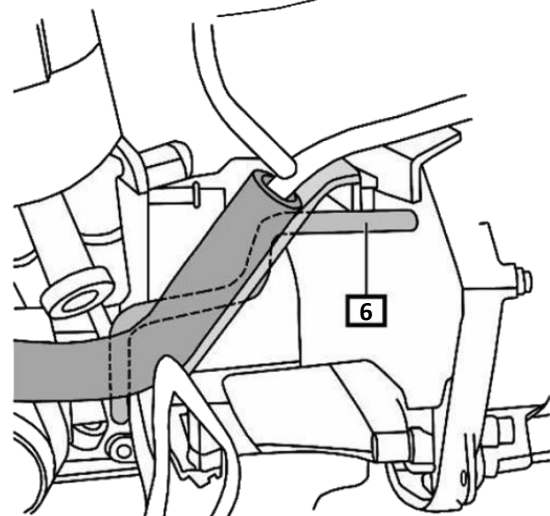
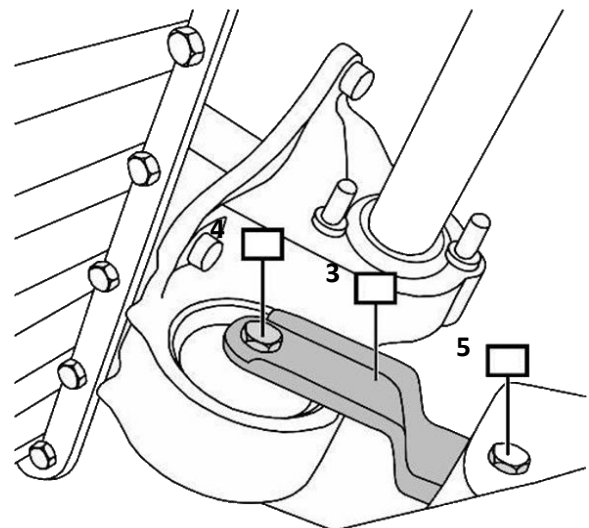
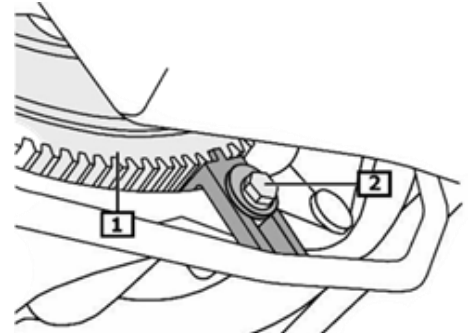

- 17) Remove the engine cover
- 18) Remove the expansion tank (no. 7)
- 19) Remove the ECU support (no. 11)
- 20) Remove the engine bracket (no. 8)
- 21) Remove the mounting (no. 9)
- 22) Remove the timing belt cover (no. 10)

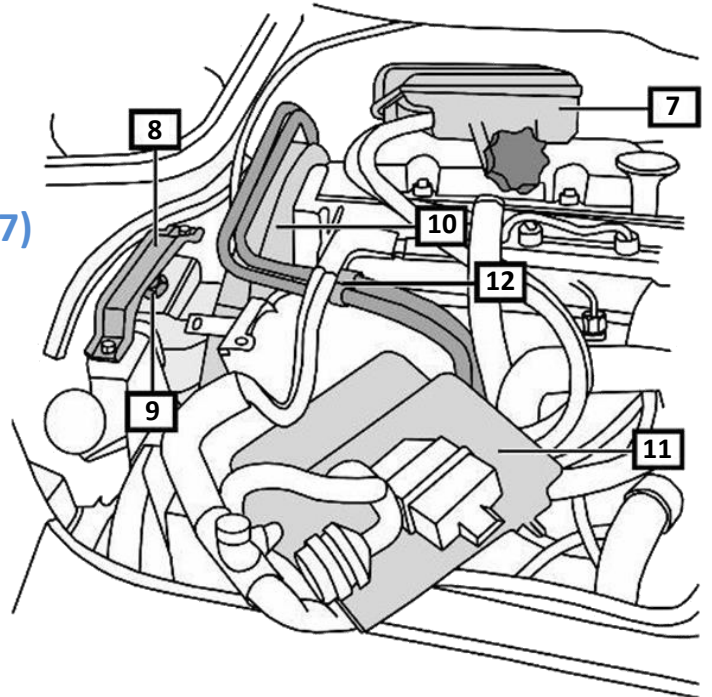

- 23) Support the engine
- 24) Unscrew the nut from the engine mount (no. 14)
- 25) Unscrew the bolts for the engine mount (no. 15)
- 26) Remove the engine mount (no. 13)
- 27) Install the engine setting rods

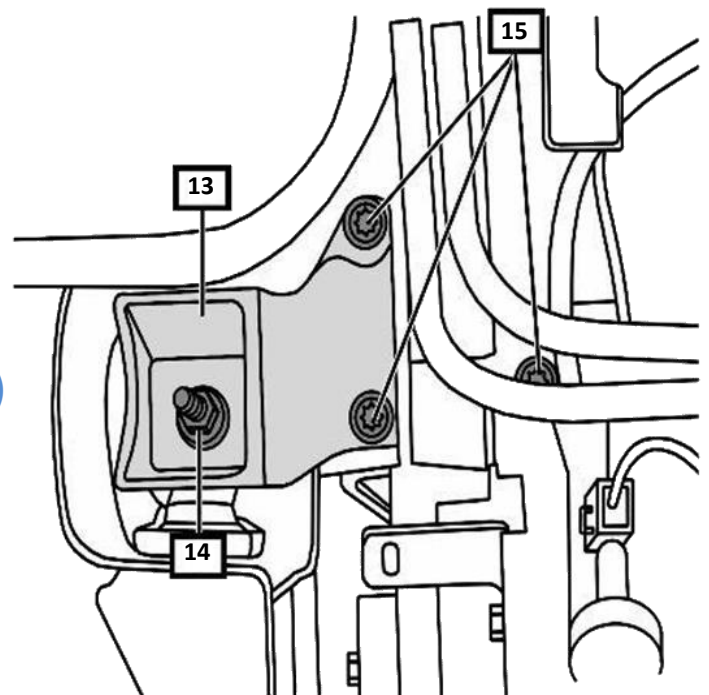

28) Install the camshaft locking rod (no. 16)

29) Loosen the tensioner roller by rotating it clockwise (no. 17)

30) Remove the timing belt

31) Unscrew and remove the idler roller

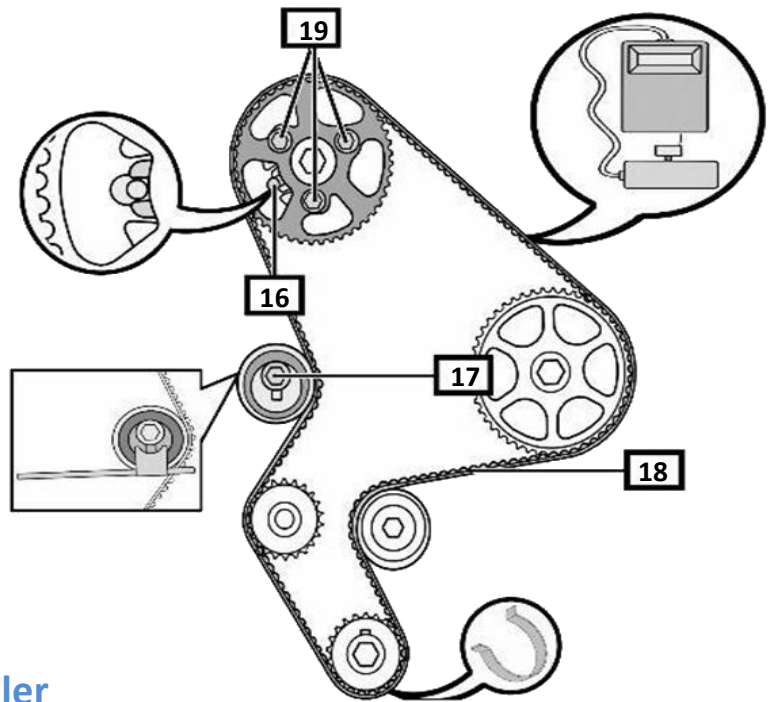

The crankshaft and the injection pump gear must not be rotated while the timing belt is removed.

RE-INSTALLATION

1) Re-install the tensioner and idler rollers

2) Loosen the bolts of the camshaft gear by one-sixth of a turn (no. 19)



Check that the camshaft gear is functioning properly and make sure that the crankshaft keys remain in contact with the alignment tool.

3) Rotate the camshaft gear clockwise to the end of the slotted mounting holes

4) Install the timing belt in the following sequence:

Camshaft gear, injection pump gear, idler roller (GE359.30), crankshaft gear, water pump, and tensioner roller (GT359.32)



Use the retaining clip: OE 0188-K
The offset must not exceed the width of one tooth on the camshaft gear.

5) Tension the timing belt slightly (no. 18)

6) Tighten the tensioner roller bolt slightly (no. 17)

7) Remove the retaining clip: OE (0188-K)

8) Fit the timing belt tension gauge: OE 0192



Make sure the tensioning lever is correctly installed: OE 0188-J2

9) Rotate the tensioner roller anti-clockwise

Turn it until the value 131 ± 2 Hz or 98 ± 2 SEEM is reached

10) Tighten the tensioner roller bolt (no. 17)

Tightening torque: 25 ± 2 Nm

11) Remove the timing belt tension gauge: OE 0192



Unscrew one of the camshaft gear bolts and check that the bolts are not up against the end of the slotted mounting holes, otherwise the timing belt will need to be refitted (no. 19). With this type of roller, make sure that the tensioner is correctly fitted to the engine block and the tensioner roller is straight before applying the final tightening torque.

12) Tighten the camshaft gear bolts (no. 19)

Tightening torque: **20 Nm**

13) Remove the camshaft locking rods (no. 16)**14) Remove the engine flywheel locking tool (no. 6)****15) Rotate the crankshaft eight full revolutions clockwise**

(DO NOT ROTATE THE CRANKSHAFT ANTI-CLOCKWISE)

16) Install the engine flywheel locking tool (no. 6)**17) Install the camshaft locking rod (no. 16)****18) Loosen the camshaft gear fasteners (no. 19)**

Hand tighten the camshaft gear fasteners **(no. 19)**

Loosen the camshaft gear fasteners by one-sixth of a turn **(no. 19)**

19) Loosen the tensioner roller bolt (no. 17)**20) Fit the timing belt tension gauge****21) Install the tensioning lever: OE 0188-J2****22) Rotate the tensioner roller assembly clockwise until the value of $80 \pm 3\text{Hz}$**

or $54 \pm 2\text{ SEEM}$ is reached

23) Tighten the tensioner roller bolt (no. 17)

Tightening torque: **$25 \pm 2\text{ Nm}$**

24) Tighten the camshaft gear bolts (no. 19)

Tightening torque: **20 Nm**

25) Remove the timing belt tension gauge

Remove the camshaft locking rods **(no. 16)**



The timing belt tension must be 54 ± 2 SEEM/ 80 ± 3 Hz. If the timing belt tension does not correspond to the specified value, repeat the entire adjustment procedure.

26) Remove the engine flywheel locking tool (no. 6)

27) Rotate the crankshaft two full revolutions in the direction of rotation of the engine

Install the camshaft locking rod(s) (no. 16)



The offset between the hole in the camshaft wheel and the mounting hole must not exceed 1 mm.

28) Complete re-installation in the reverse order of removal

29) Install a new accessories belt

30) Document the replacement of the timing belt



Recommendations

The belt must be pre-tensioned to 131 ± 2 Hz or 98 ± 2 SEEM units. Then, after 8 turns of the crankshaft, a tension of 80 ± 3 Hz or 54 ± 2 SEEM units must be applied.

The accessories belt must always be replaced after removal.

Follow the vehicle manufacturer's installation procedures and apply the specified tightening torques.

Refer to the vehicle applications in our online catalogue: eshop.ntn-snr.com



Scan this QR code to access our online catalogue.

FOLLOW THE RECOMMENDATIONS
OF THE VEHICLE MANUFACTURER

©NTN-SNR ROULEMENTS

The contents of this document are the copyright of the publisher and any reproduction, even partial, is prohibited without permission.

Despite the care taken in preparing this document, NTN-SNR Roulements disclaims any liability for errors or omissions that may slip through, as well as for losses or direct or indirect damage arising from its use.

