

# MEGATORQUE MOTOR™



PS Series (Complies with UL Standards and CE Mark)

PN Series (Complies with UL Standards and CE Mark)

PN Series with Brake

Z Series with High Environmental Resistance

(Dust-tight, Watertight)

Diverse selection of high performance motors with full consideration for safety and the environment

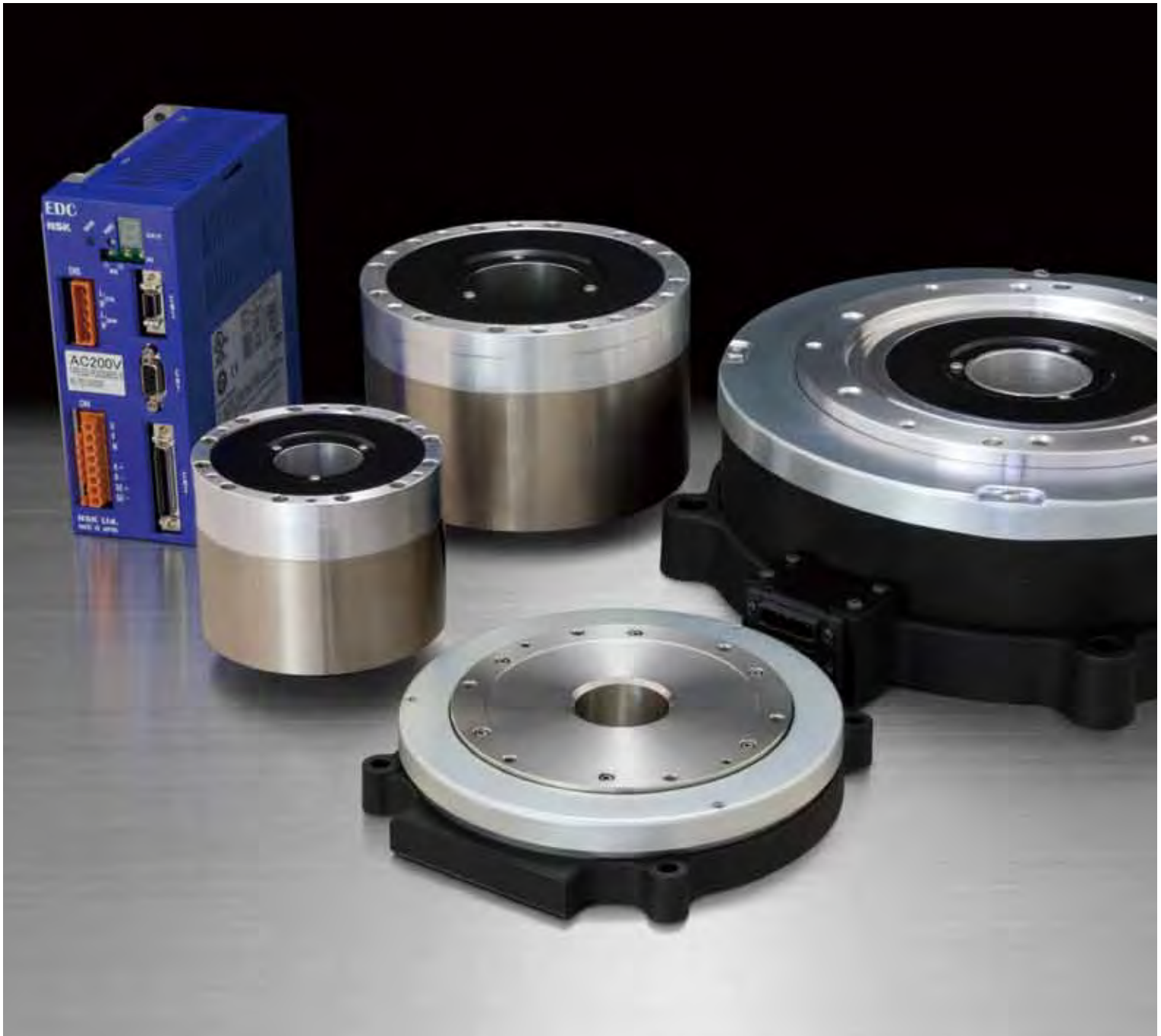

# The Megatorque Motor draws upon NSK's combined strengths in manufacturing bearings, sensors and motors.

The NSK Megatorque Motor's reliability effectively demonstrates NSK's full manufacturing and design capabilities. Complete aftercare support is available through our many offices worldwide. The Megatorque Motor boosts productivity and achieves high performance in full compliance with the latest safety standards.

Comparison of major features

| PS Series  | PN/Z Series   |
|--|---|
| Outer rotor  | Inner rotor   |
| Small diameter   | Low profile   |
| Fixed from the bottom  | Fixed from the top  |
| High rotational speed  | High rigidity   |
| Small footprint  | Low motor height  |
| Compact, clean, high accuracy, hollow structure, minimum maintenance                       |   |
| For high-speed positioning of medium/light loads   | For positioning of heavy loads  |
| <p>(1) Outer rotor<br/>(2) Small diameter<br/>(3) Fixed from the bottom<br/>Base Plate</p> | <p>(1) Inner rotor<br/>(2) Low profile<br/>(3) Fixed from the top</p> |

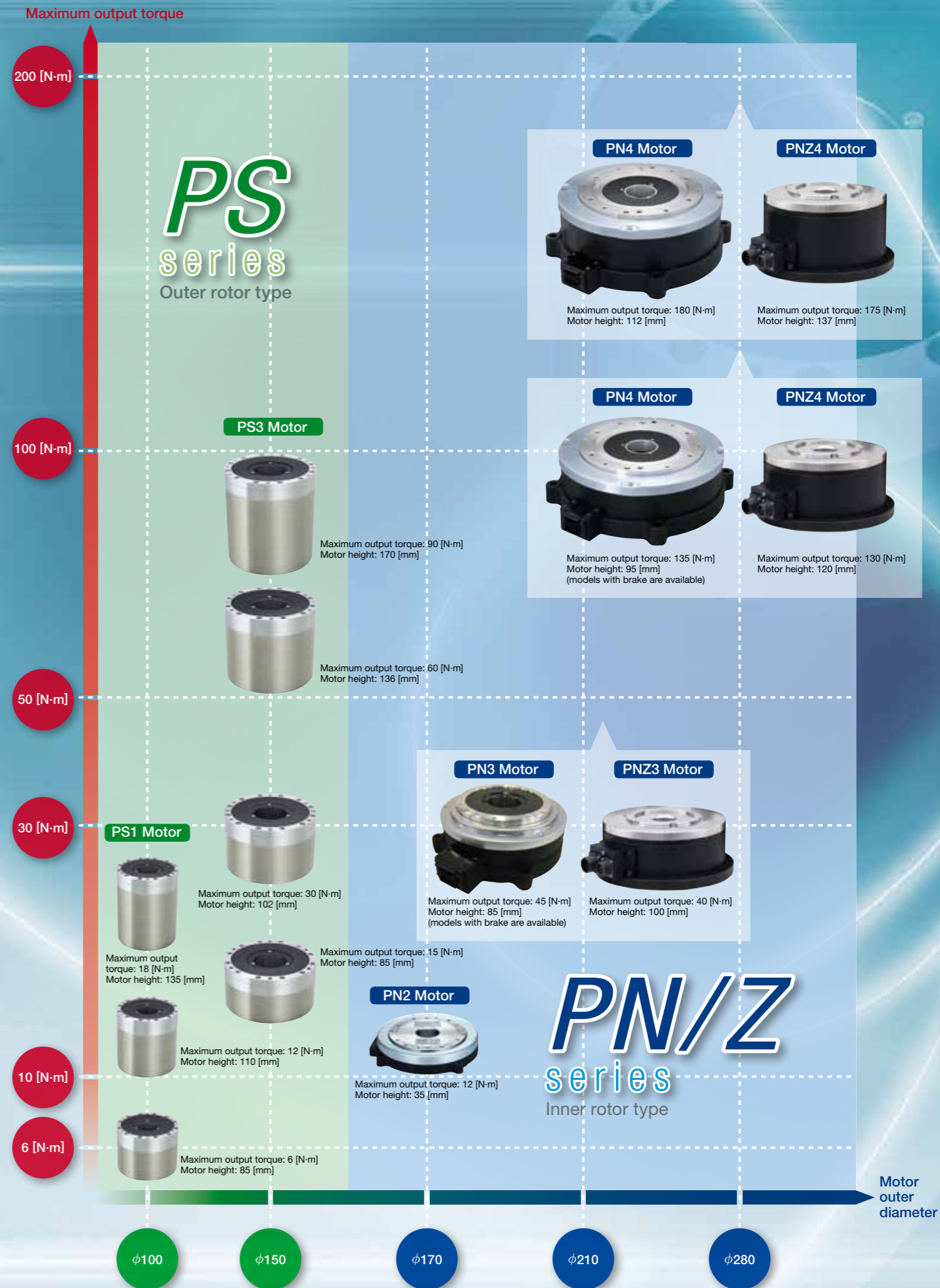

# A direct-drive motor with advanced features only available from NSK

With advanced features, including high torque, high resolution, maximum rotational speed of 10 [s<sup>-1</sup>] (PS Series), high rigidity and compactness, the Megatorque Motor complies with CE mark (PS/PN Series), UL standards (PS/PN Series), and the EU RoHS directive. These innovative direct-drive motors are extremely accurate, light-weight, and boost the productivity of various devices.

## High resolution

The Megatorque Motor's absolute position sensor is capable of a high resolution of 2 621 440 [count/revolution] and repeatability of ±2 [arc-sec]. It requires no homing operations and facilitates the development of highly accurate devices.

Resolution of position sensor

**2 621 440**  
[count/revolution]

## Shortened positioning time

A new servo algorithm shortens settling time to less than one-fifth of conventional NSK motors. Shortened positioning time boosts the productivity of various devices.

Settling time

Less than **1/5**

## High torque

The optimal magnetic field design gives it more than twice as much force density as conventional NSK motors. A maximum of 50% increase in motor torque increases productivity during high acceleration/deceleration drives.

Force density

More than **twice** as much

## Compact motor

NSK's advanced design technology has produced two unique motor series: the low profile PN Series (height of PN2: 35 [mm]) and the light and compact PS Series (outer diameter of PS1: φ100 [mm]).

Height

**35**  
[mm]  
(PN2)

Outer diameter

**φ100**  
[mm]  
(PS1)

## Extensive lineup

The product lineup includes the PN Series with brake and the Z Series with High Environmental Resistance (dust-tight, watertight).

With  
brake

**IP66M**  
compliant

## High accuracy and interchangeability

Interchangeable Motors and Driver Units can be randomly matched. Increased positioning accuracy of 90 [arc-sec] and interchangeability improve ease of use.

Absolute positioning accuracy

**90**  
[arc-sec]

## Intelligent

The EDC Driver Unit's positioning controller function is provided as a standard feature. In addition, an electronic gear function is built in for setting the pulse train position command. The EDC Megaterm software is used to collect, edit, and monitor data.

Positioning controller function  
is a standard feature

## Full consideration for people and the environment

Compliance with international safety standards (UL Standards, CE mark) assures worldwide applicability (PS/PN Series). The Megatorque Motor is environment friendly and complies with the EU RoHS Directive.

Compliant with UL Standards,  
CE mark, EU RoHS Directive



Resolution of  
built-in absolute  
position sensor

**2.62** million  
[count/revolution]

PS Series  
Maximum rotational  
speed

**10** [s<sup>-1</sup>]  
(varies by motor model)

## Megatorque Motors in a variety of applications and installations

Application 1: **PS Series**  
Inspection equipment for electronic parts

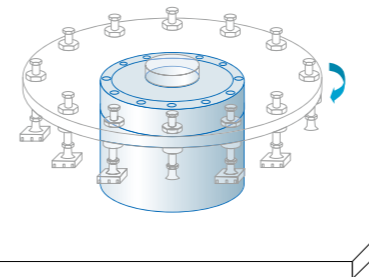

- High speed and high accuracy
- Compact
- Clean
- Hollow structure (convenient for wiring/tubing)

Application 2: **PS Series**  
Transport for DVD/CD

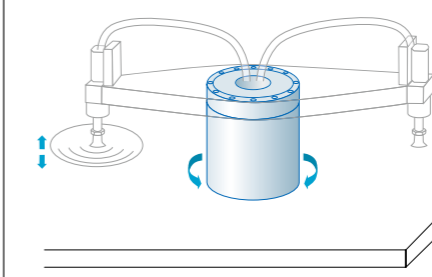

- High speed and high accuracy
- Clean
- Maintenance free
- Hollow structure (convenient for wiring/tubing)

Application 3: **PS Series**  
Inspection conveyor for medical devices

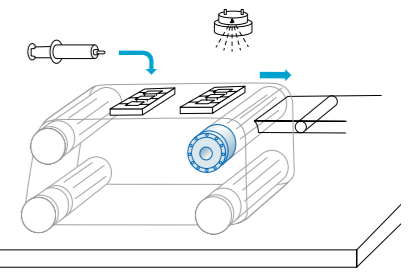

- Compact
- Clean
- Maintenance free

Application 4: **PN Series**  
Automatic part assembly

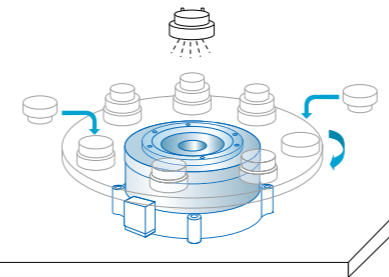

- High speed and high accuracy
- Compact
- Advanced functions (unequal partitioned positioning and short-cut positioning)

Application 5: **PN Series**  
Turn table and alignment for flat panels

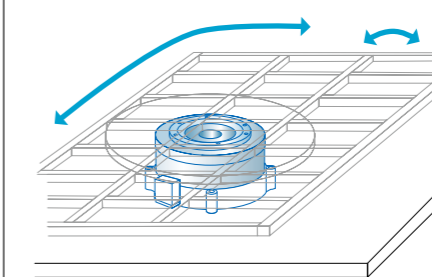

- Compact
- Maintenance free
- Advanced functions (fine positioning)
- High torque

Application 6: **PN Series + PS Series**  
Manufacturing line for electric parts

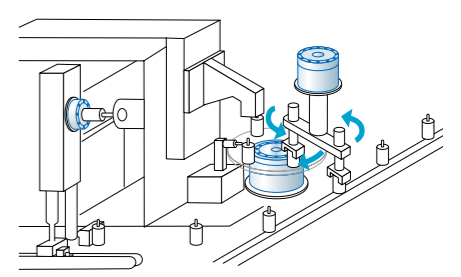

- High-speed
- Compact
- Maintenance free

Application 7: **PN Series with Brake**  
Transverse installation

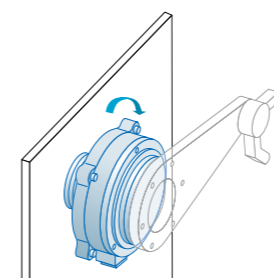

- Prevents unwanted rotation

Application 8: **PN Series with Brake**  
Installation with external load applied

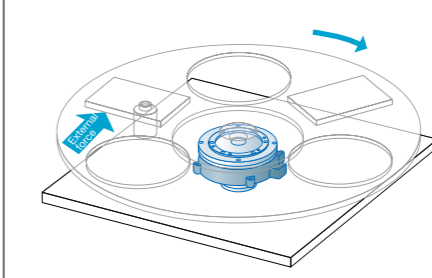

- Holds the position

Application 9: **Z Series with High Environmental Resistance**  
Installation for manufacturing automotive components

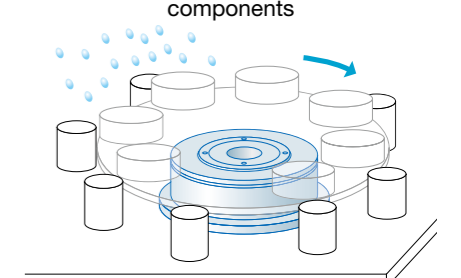

- Environmental resistance (environmental protection against water, oil, particulates, etc.)

# 1 Selection Guide

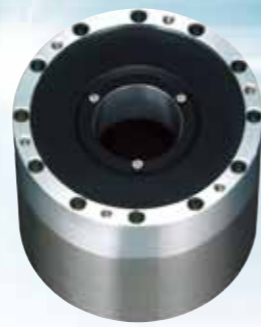

## PS Series (Outer Rotor Type)

| Series  | PS Series  |  |   |   |
|---|--|--|---|---|
| Model   | PS1 Motor  |  | PS3 Motor   |   |
| <p>Maximum output torque [N·m]</p> <p>Motor height [mm]</p> |  |  |   |   |
| Motor outer diameter [mm]                                   | φ100   |  | φ150  |   |
| Motor hollow diameter [mm]                                  | φ35  |  | φ56   |   |
| Maximum rotational speed [s <sup>-1</sup> ]                 | 10   |  | 10  | 8 |
| Resolution of position sensor [count/revolution]            | 2 621 440  |  |   |   |
| Absolute positioning accuracy [arc-sec]                     | 90 (Interchangeable type) (at ambient temperature of 25 ± 5 [°C])  |  |   |   |
| Driver unit model (Dimensions: W × D × H [mm])              | EDC Driver Unit  |  |   |   |
|   |  |  |   |   |
| Reference page  | Motor: 9–12  |  | Driver unit: 19–24  |   |
| Features  | Shortened positioning time<br>Compact motor<br>Interchangeable, highly accurate absolute position sensor |  | Compact driver unit<br>Complies with UL Standards and CE Mark |   |

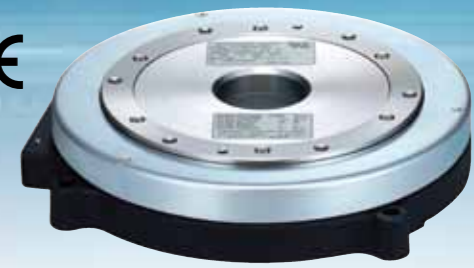

## PN Series (Inner Rotor Type)

| Series  | PN Series  |           |   |
|---|--|-----------|---|
| Model   | PN2 Motor  | PN3 Motor | PN4 Motor   |
| <p>Maximum output torque [N·m]</p> <p>Motor height [mm]</p> |  |           |   |
| Motor outer diameter [mm]                                   | φ170   | φ210      | φ280  |
| Motor hollow diameter [mm]                                  | φ36  | φ56       | φ50   |
| Maximum rotational speed [s <sup>-1</sup> ]                 | 2  | 3         | 3   |
| Resolution of position sensor [count/revolution]            | 2 621 440  |           |   |
| Absolute positioning accuracy [arc-sec]                     | 90 (Interchangeable type) (at ambient temperature of 25 ± 5 [°C])  |           |   |
| Driver unit model (Dimensions: W × D × H [mm])              | EDC Driver Unit  |           |   |
|   |  |           |   |
| Reference page  | Motor: 13–14   |           | Driver unit: 19–24  |
| Features  | Shortened positioning time<br>Low profile and high rigidity motor<br>Interchangeable, highly accurate absolute position sensor |           | Compact driver unit<br>Complies with UL Standards and CE Mark |

## PN Series with Brake — Inner Rotor Type



| Series   | PN Series with Brake   |   |
|--|--|---|
| Model  | PN3 Motor  | PN4 Motor   |
|  |  |   |
| <p>45<br/>(97)</p>                               |  | <p>135<br/>(111)</p>  |
| Motor outer diameter [mm]                        | φ210   | φ280  |
| Motor hollow diameter [mm]                       | φ32  | φ32   |
| Maximum rotational speed [s <sup>-1</sup> ]      | 3  | 3   |
| Resolution of position sensor [count/revolution] | 2 621 440  |   |
| Absolute positioning accuracy [arc-sec]          | 90 (Interchangeable type) (at ambient temperature of 25 ± 5 [°C])  |   |
| Driver unit model (Dimensions: W × D × H [mm])   | EDC Driver Unit<br><p>90 × 140 × 190</p>   |   |
| Reference page                                   | Motor: 15–16   | Driver unit: 19–24  |
| Features   | Shortened positioning time<br>Flat with high rigidity<br>Interchangeable, highly accurate absolute position sensor | Compact driver unit<br>Negative actuation type holding brake without backlash |

## Z Series with High Environmental Resistance— Inner Rotor Type



| Series   | Z Series   |   |
|--|--|---|
| Model  | PNZ3 Motor   | PNZ4 Motor  |
|  |  |   |
| <p>40<br/>(100)</p>                              | <p>130<br/>(120)</p>   | <p>175<br/>(137)</p>  |
| Motor outer diameter [mm] (flange not included)  | φ220   | φ286  |
| Motor hollow diameter [mm]                       | φ44  | φ37   |
| Maximum rotational speed [s <sup>-1</sup> ]      | 3  | 3   |
| Resolution of position sensor [count/revolution] | 2 621 440  |   |
| Absolute positioning accuracy [arc-sec]          | 90 (Interchangeable type) (at ambient temperature of 25 ± 5 [°C])  |   |
| Driver unit model (Dimensions: W × D × H [mm])   | EDC Driver Unit<br><p>90 × 140 × 190</p>   |   |
| Reference page                                   | Motor: 17–18   | Driver unit: 19–24  |
| Features   | Shortened positioning time<br>Flat with high rigidity<br>Interchangeable, highly accurate absolute position sensor | Compact driver unit<br>Certified with IP rating for dust and water ingress protection |

### Ingress Protection (IP) Classification Test under IEC Standards

Megatorque Motor Z Series with High Environmental Resistance complies with IP66M under IEC standards certified by TÜV Rheinland Japan Ltd.



The Z Series was certified with an IP rating after compliance testing under the following two standards:

- IEC 60529 Degrees of protection provided by enclosures for electrical equipment (IP code)
- IEC 60034-5 Rotating electrical machines—Part 5

The first characteristic numeral of the IP code stands for the degree of protection against ingress of solid foreign objects, such as dust, with “6” (IP6X) indicating completely dust-tight.

The second characteristic numeral of the IP code represents the degree of protection against ingress of water (waterproofness), with “6” (IPX6) indicating protection from high-pressure (100ℓ/min) water from any angle. A final “M” indicates the watertight test was conducted with a motor rotating.

# 2 Motor Specifications



## 2.1 PS Series

### 2.1.1 Reference Number Coding of Motor

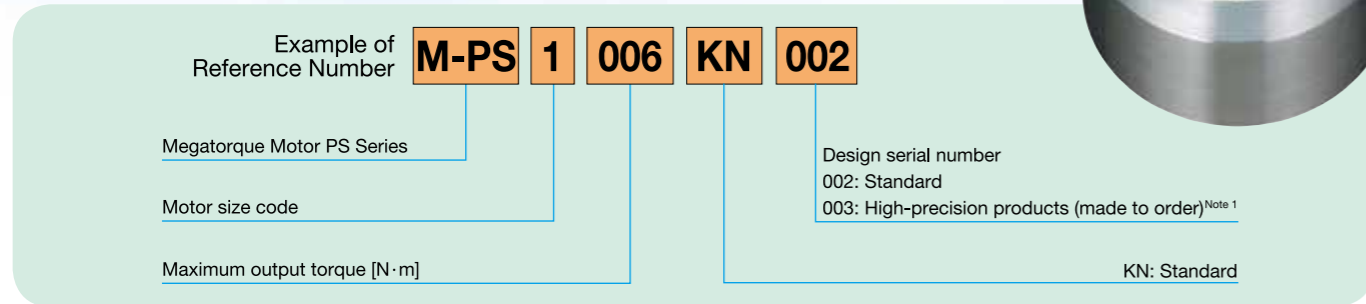

### 2.1.2 Specifications

| Functional item   | Reference number | M-PS1006KN002  | M-PS1012KN002 | M-PS1018KN002 |
|---|------------------|--|---------------|---------------|
| Motor outer diameter [mm]                                 |                  |  | φ100          |               |
| Maximum output torque [N·m]                               |                  | 6  | 12            | 18            |
| Rated output torque [N·m]                                 |                  | 2  | 4             | 6             |
| Motor height [mm]   |                  | 85   | 110           | 135           |
| Motor hollow diameter [mm]                                |                  |  | φ35           |               |
| Maximum rotational speed [s <sup>-1</sup> ]               |                  |  | 10            |               |
| Rated rotational speed [s <sup>-1</sup> ]                 |                  |  | 5             |               |
| Resolution of position sensor [count/revolution]          |                  |  | 2 621 440     |               |
| Absolute positioning accuracy [arc-sec] <sup>Note 1</sup> |                  | 90 (Interchangeable type) (at ambient temperature of 25 ± 5 [°C])  |               |               |
| Repeatability [arc-sec]                                   |                  |  | ±2            |               |
| Allowable axial load [N]*1                                |                  |  | 1 000         |               |
| Allowable radial load [N]*2                               |                  |  | 820           |               |
| Allowable moment load [N·m]                               |                  |  | 28            |               |
| Rotor inertia [kg·m <sup>2</sup> ]                        |                  | 0.0024   | 0.0031        | 0.0038        |
| Allowable range of inertia [kg·m <sup>2</sup> ]           |                  | 0.015 to 0.24  | 0.03 to 0.31  | 0.03 to 0.38  |
| Mass [kg]   |                  | 2.4  | 3.5           | 4.5           |
| Environmental conditions                                  |                  | Ambient temperature 0 to 40 [°C]; humidity: 20 to 80 [%]; use indoors, free from dust, condensation and corrosive gas. IP30 or equivalent. |               |               |

- Please consult with NSK in case of a simultaneous application of axial load, radial load and moment load to a Motor.
- \*1 Under no radial load \*2 Under no axial load
- For an oscillating operation less than 45 [°], turn the Motor 90 [°] or more at least once a day.
- Note 1: Absolute positioning accuracy of high-precision products (made to order) is 30 [arc-sec]. (Interchangeable type) (at ambient temperature of 25 ± 5 [°C]) Cable length is up to 8 [m].
- Conditions outside the allowable range of inertia may be applicable, depending on operating conditions. Contact NSK for details.

### 2.1.3 Rotational Speed and Output Torque Characteristics

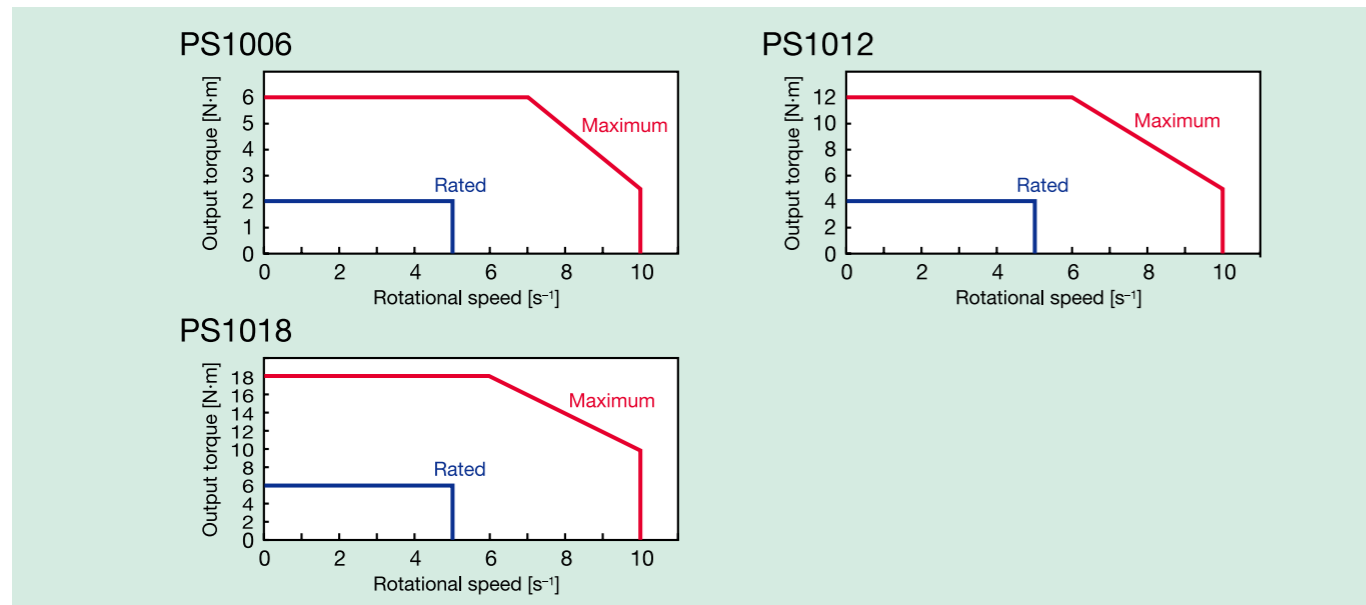

### 2.1.4 Motor Dimensions

M-PS1006KN002

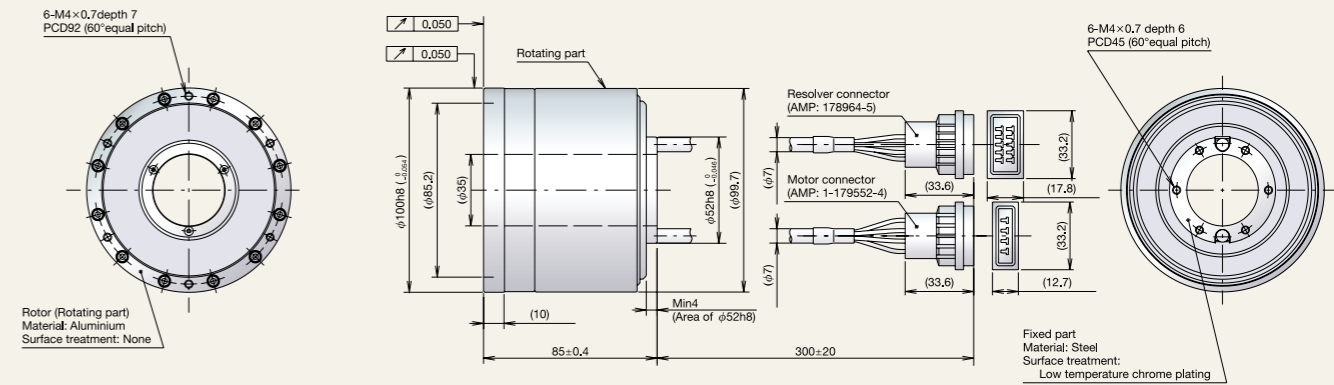

M-PS1012KN002

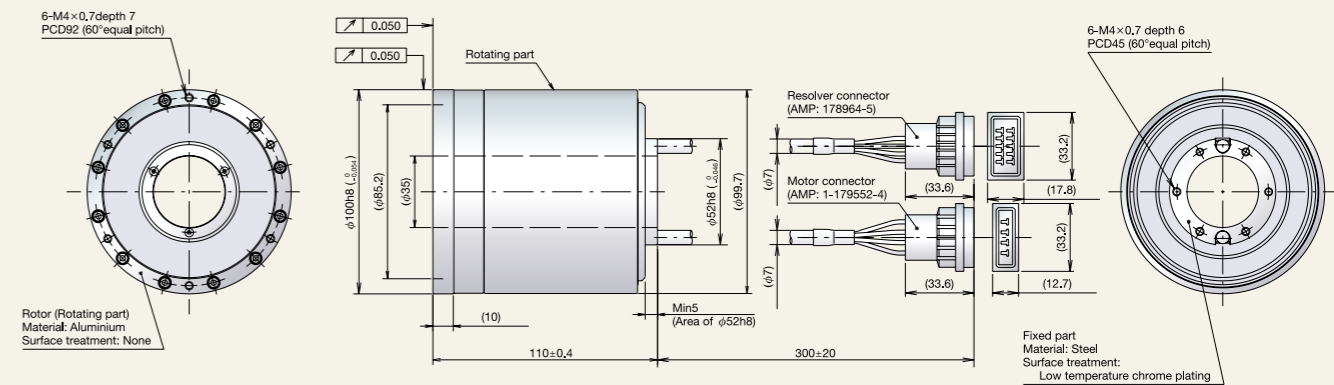

M-PS1018KN002

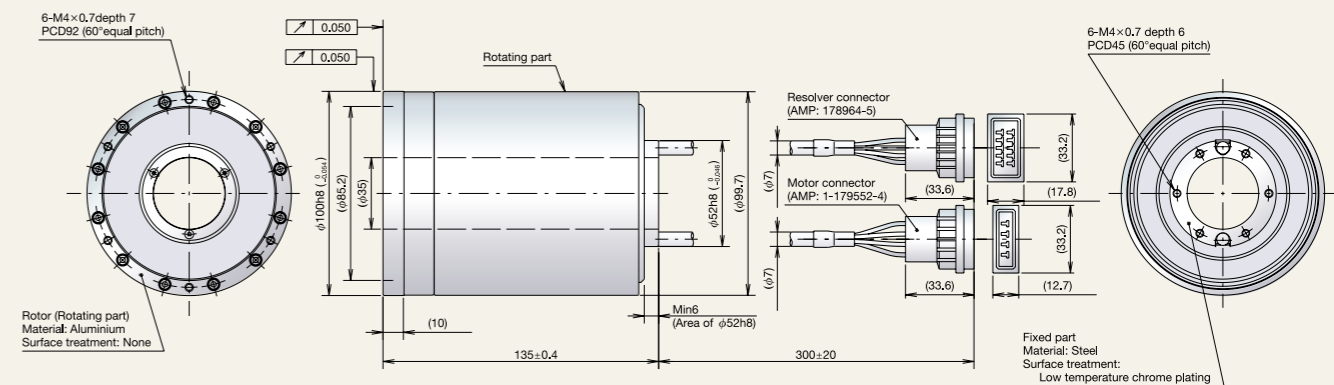

1. The bend radius of the motor cable lead (φ7) and the resolver cable lead (φ7) should be R30 [mm] or more.
2. Do not use the leads of the motor cable and the resolver cable with flexing motion.
3. Do not add the stress (tension, vibration, etc.) to the joint of the leads and the connector. It causes the disconnection and the loose connection.

## 2 Motor Specifications

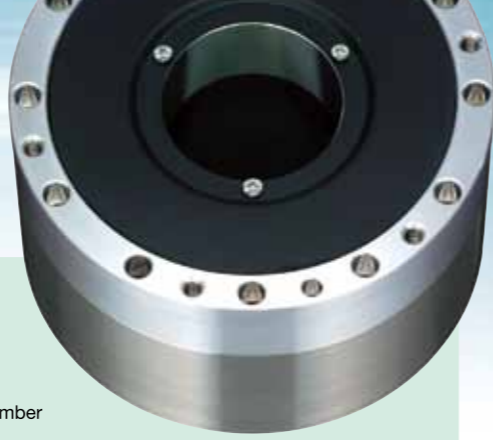

### 2.1.5 Reference Number Coding of Motor

Example of Reference Number **M-PS 3 015 KN 002**

Megatorque Motor PS Series

Motor size code

Maximum output torque [N·m]

Design serial number  
 002: Standard  
 003: High-precision products (made to order)<sup>Note 1</sup>  
 701: Highly accurate upper surface runout (made to order)

KN: Standard

### 2.1.6 Specifications

| Functional item   | Reference number | M-PS3015KN002  | M-PS3030KN002 | M-PS3060KN002 | M-PS3090KN002 |
|---|------------------|--|---------------|---------------|---------------|
| Motor outer diameter [mm]                                 |                  | φ150   |               |               |               |
| Maximum output torque [N·m]                               |                  | 15   | 30            | 60            | 90            |
| Rated output torque [N·m]                                 |                  | 5  | 10            | 20            | 30            |
| Motor height [mm]   |                  | 85   | 102           | 136           | 170           |
| Motor hollow diameter [mm]                                |                  | φ56  |               |               |               |
| Maximum rotational speed [s <sup>-1</sup> ]               |                  | 10   |               | 8             | 5             |
| Rated rotational speed [s <sup>-1</sup> ]                 |                  | 5  |               | 1             |               |
| Resolution of position sensor [count/revolution]          |                  | 2 621 440  |               |               |               |
| Absolute positioning accuracy [arc-sec] <sup>Note 1</sup> |                  | 90 (Interchangeable type) (at ambient temperature of 25 ± 5 [°C])  |               |               |               |
| Repeatability [arc-sec]                                   |                  | ±2   |               |               |               |
| Allowable axial load [N] <sup>*1</sup>                    |                  | 2 000  |               |               |               |
| Allowable radial load [N] <sup>*2</sup>                   |                  | 1 700  |               |               |               |
| Allowable moment load [N·m]                               |                  | 42   |               |               |               |
| Rotor inertia [kg·m <sup>2</sup> ]                        |                  | 0.011  | 0.014         | 0.019         | 0.024         |
| Allowable range of inertia [kg·m <sup>2</sup> ]           |                  | 0 to 1.1   | 0 to 1.4      | 0.12 to 1.9   | 0.12 to 2.4   |
| Mass [kg]   |                  | 5.5  | 6.9           | 11.0          | 13.8          |
| Environmental conditions                                  |                  | Ambient temperature 0 to 40 [°C]; humidity: 20 to 80 [%]; use indoors, free from dust, condensation and corrosive gas. IP30 or equivalent. |               |               |               |

- Please consult with NSK in case of a simultaneous application of axial load, radial load and moment load to a Motor.
- <sup>\*1</sup> Under no radial load    <sup>\*2</sup> Under no axial load
- For an oscillating operation less than 45 [°], turn the Motor 90 [°] or more at least once a day.
- Note 1: Absolute positioning accuracy of high-precision products (made to order) is 30 [arc-sec]. (Interchangeable type) (at ambient temperature of 25 ± 5 [°C]) Cable length is up to 8 [m].
- Conditions outside the allowable range of inertia may be applicable, depending on operating conditions. Contact NSK for details.

### 2.1.7 Rotational Speed and Output Torque Characteristics

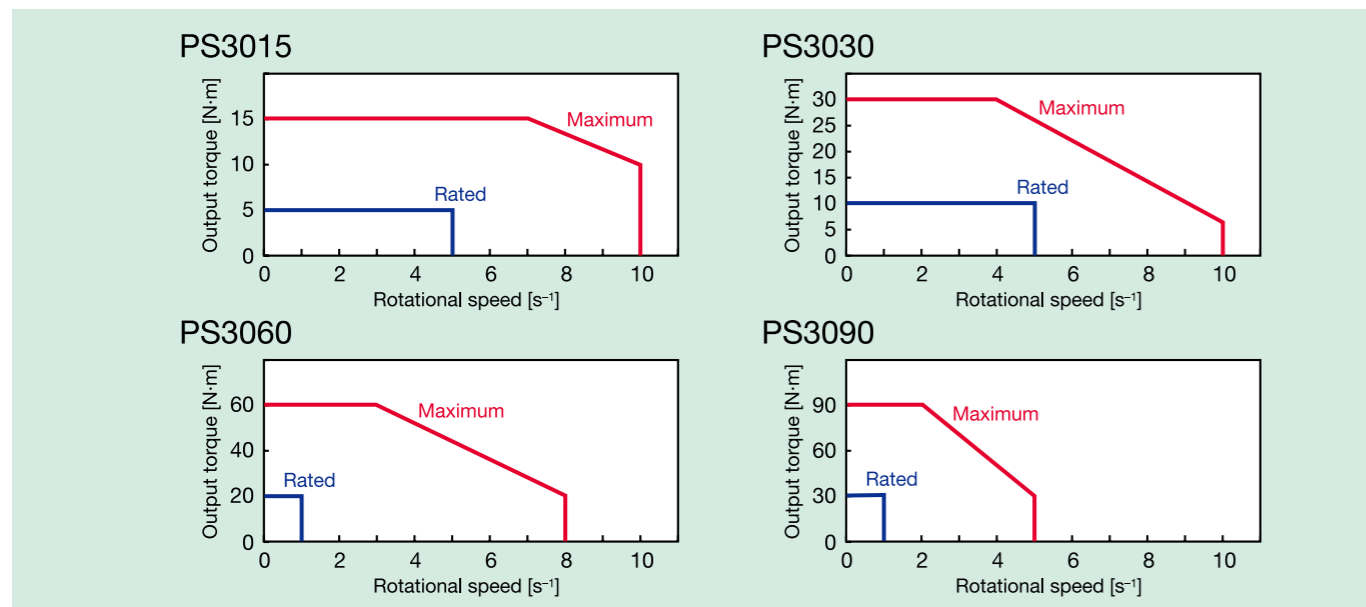

### 2.1.8 Motor Dimensions

**M-PS3015KN002**  
 Rotor (Rotating part) Material: Aluminium Surface treatment: None  
 Fixed part Material: Steel Surface treatment: Low temperature chrome plating

**M-PS3030KN002**  
 Rotor (Rotating part) Material: Aluminium Surface treatment: None  
 Fixed part Material: Steel Surface treatment: Low temperature chrome plating

**M-PS3060KN002**  
 Rotor (Rotating part) Material: Aluminium Surface treatment: None  
 Fixed part Material: Steel Surface treatment: Low temperature chrome plating

**M-PS3090KN002**  
 Rotor (Rotating part) Material: Aluminium Surface treatment: None  
 Fixed part Material: Steel Surface treatment: Low temperature chrome plating

1. \*0.010 for highly accurate upper surface runout type (design serial number: 701)  
 2. The bend radius of the motor cable lead (φ7) and the resolver cable lead (φ7) should be R30 [mm] or more.  
 3. Do not use the leads of the motor cable and the resolver cable with flexing motion.  
 4. Do not add the stress (tension, vibration, etc.) to the joint of the leads and the connector. It causes the disconnection and the loose connection.  
 5. Set tolerance of the inserting pin for clearance fit.  
 6. Do not apply excessive load and/or impact to the motor when inserting the pin.  
 7. Use the pinhole as positioning purpose only.  
 Do not use the pinhole to hold the load on rotor.



# 2.2 PN Series

## 2.2.1 Reference Number Coding of Motor

Example of Reference Number **M-PN 3 045 KN 001**

Megatorque Motor PN Series

Motor size code

Maximum output torque [N·m]

Design serial number  
 201: Standard (PN2)  
 001: Standard (PN3/PN4)  
 701: Highly accurate upper surface runout (PN3/PN4, made to order)

KN: Standard



## 2.2.2 Specifications

| Functional item                                  | Reference number | M-PN2012KN201<br>(Note 1)   | M-PN3045KN001 | M-PN4135KN001 | M-PN4180KN001 |
|--|------------------|---|---------------|---------------|---------------|
| Motor outer diameter [mm]                        |                  | φ170  | φ210          | φ280          |               |
| Maximum output torque [N·m]                      |                  | 12  | 45            | 135           | 180           |
| Rated output torque [N·m]                        |                  | 2   | 15            | 45            | 60            |
| Motor height [mm]                                |                  | 35  | 85            | 95            | 112           |
| Motor hollow diameter [mm]                       |                  | φ36   | φ56           | φ50           |               |
| Maximum rotational speed [s <sup>-1</sup> ]      |                  | 2   | 3             |               |               |
| Rated rotational speed [s <sup>-1</sup> ]        |                  | 1   |               |               |               |
| Resolution of position sensor [count/revolution] |                  | 2 621 440   |               |               |               |
| Absolute positioning accuracy [arc-sec]          |                  | 90 (Interchangeable type) (at ambient temperature of 25 ± 5 [°C])   |               |               |               |
| Repeatability [arc-sec]                          |                  | ±2  |               |               |               |
| Allowable axial load [N]*1                       |                  | 1 000   | 4 500         | 9 500         |               |
| Allowable radial load [N]*2                      |                  | 300   | 4 500         | 9 500         |               |
| Allowable moment load [N·m]                      |                  | 20  | 80            | 160           | 200           |
| Rotor inertia [kg·m <sup>2</sup> ]               |                  | 0.0024  | 0.011         | 0.057         | 0.065         |
| Allowable range of inertia [kg·m <sup>2</sup> ]  |                  | 0.02 to 0.24  | 0.11 to 0.77  | 0.57 to 3.99  | 0.65 to 4.55  |
| Mass [kg]  |                  | 3.7   | 13            | 26            | 31            |
| Environmental conditions                         |                  | Ambient temperature 0 to 40 [°C]; humidity: 20 to 80%; use indoors, free from dust, condensation and corrosive gas. IP30 or equivalent. |               |               |               |

- Please consult with NSK in case of a simultaneous application of axial load, radial load and moment load to a Motor.
- \*1 Under no radial load \*2 Under no axial load
- For an oscillating operation less than 45 [°], turn the Motor 90 [°] or more at least once a day.
- Note 1: Cable length for PN2012 is up to 8 [m].
- Conditions outside the allowable range of inertia (about 700 times the rotor's inertia) may be applicable, depending on operating conditions. Contact NSK for details.

## 2.2.3 Rotational Speed and Output Torque Characteristics

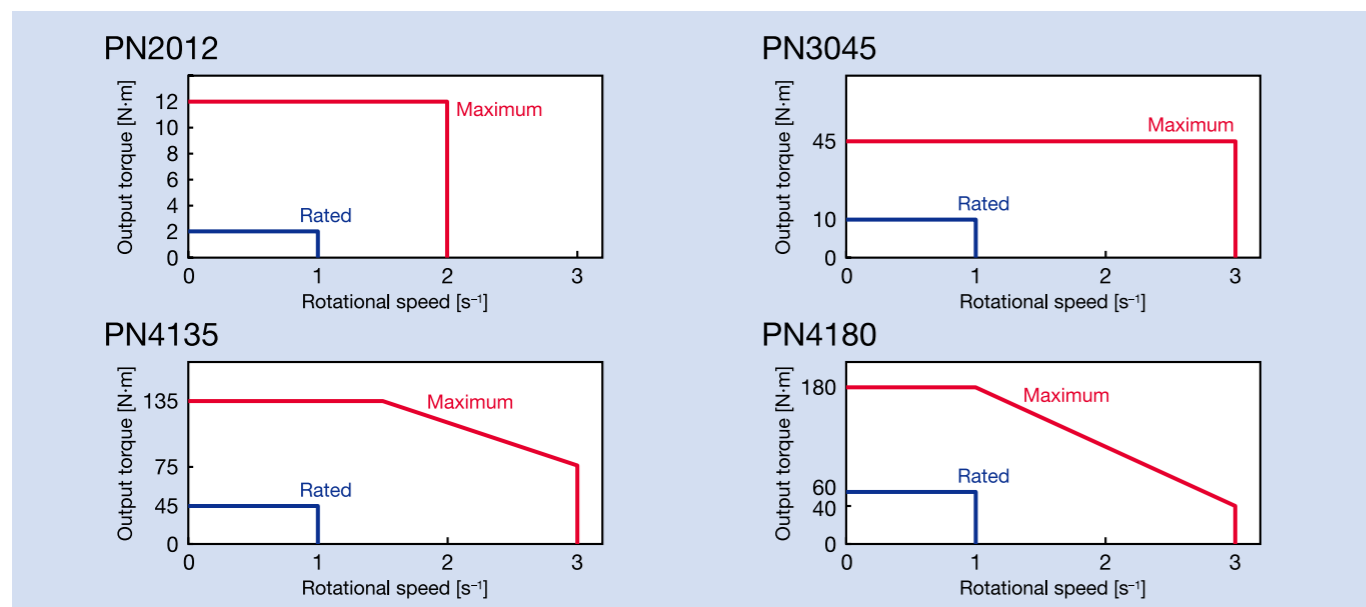

## 2.2.4 Motor Dimensions

### M-PN2012KN201

### M-PN3045KN001

### M-PN4135KN001

### M-PN4180KN001

1. For the dimensions marked \*1, extra 3 [mm] margin is required due to their variations.  
 2. \*2 0.010 for highly accurate upper surface runout type (design serial number: 701)  
 3. The bend radius of the motor cable lead (φ7) and the resolver cable lead (φ7) should be R30 [mm] or more.  
 4. Do not use the leads of the motor cable and the resolver cable with flexing motion.  
 5. Do not add the stress (tension, vibration, etc.) to the joint of the leads and the connector. It causes the disconnection and the loose connection.  
 6. Set tolerance of the inserting pin for clearance fit.  
 7. Do not apply excessive load and/or impact to the motor when inserting the pin.  
 8. Use the pinhole as positioning purpose only.  
 Do not use the pinhole to hold the load on rotor.



## 2.3 PN Series with Brake

### 2.3.1 Reference Number Coding of Motor

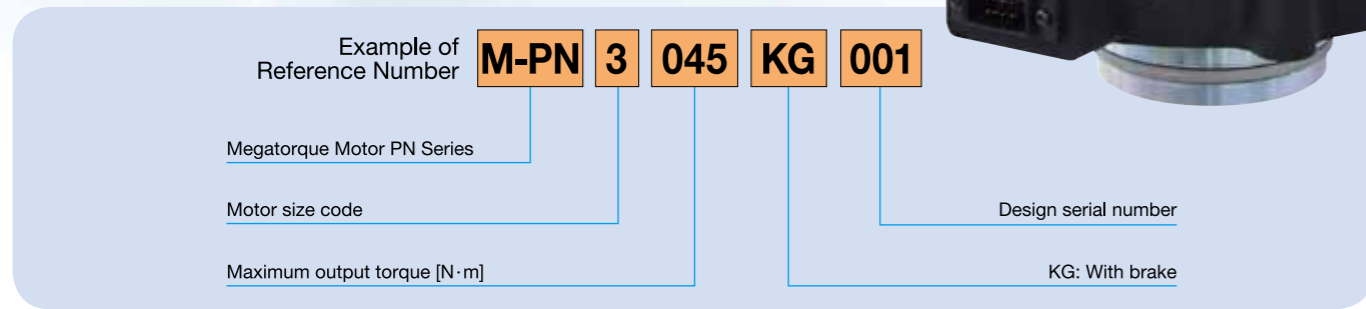

### 2.3.2 Specifications

| Functional item                                  | Reference number | M-PN3045KG001   | M-PN4135KG001 |
|--|------------------|---|---------------|
| Motor outer diameter [mm]                        |                  | φ210  | φ280          |
| Maximum output torque [N·m]                      |                  | 45  | 135           |
| Rated output torque [N·m]                        |                  | 15  | 45            |
| Motor hollow diameter [mm]                       |                  | φ32   | φ32           |
| Maximum rotational speed [s <sup>-1</sup> ]      |                  | 3   |               |
| Rated rotational speed [s <sup>-1</sup> ]        |                  | 1   |               |
| Resolution of position sensor [count/revolution] |                  | 2 621 440   |               |
| Absolute positioning accuracy [arc-sec]          |                  | 90 (Interchangeable type) (at ambient temperature of 25 ± 5 [°C]) *3  |               |
| Repeatability [arc-sec]                          |                  | ±2 *3   |               |
| Allowable axial load [N]*1                       |                  | 4 500   | 9 500         |
| Allowable radial load [N]*2                      |                  | 4 500   | 9 500         |
| Allowable moment load [N·m]                      |                  | 80  | 160           |
| Brake type                                       |                  | Negative actuation type holding brake without backlash  |               |
| Braking torque [N·m]                             |                  | 36  | 72            |
| Brake power supply [VDC]                         |                  | 24  |               |
| Brake power consumption [W]                      |                  | 26  | 40            |
| Rotor inertia [kg·m <sup>2</sup> ]               |                  | 0.018   | 0.080         |
| Allowable range of inertia [kg·m <sup>2</sup> ]  |                  | 0.11 to 0.77  | 0.57 to 3.99  |
| Mass [kg]  |                  | 18  | 34            |
| Environmental conditions                         |                  | Ambient temperature 0 to 40 [°C]; humidity: 20 to 80%; use indoors, free from dust, condensation and corrosive gas. IP30 or equivalent. |               |

- Please consult with NSK in case of a simultaneous application of axial load, radial load and moment load to a Motor.
- \*1 Under no radial load \*2 Under no axial load
- \*3 Positioning accuracy with brake released
- For an oscillating operation less than 45 [°], turn the Motor 90 [°] or more at least once a day.
- Conditions outside the allowable range of inertia (about 400 times the rotor inertia) may be applicable, depending on operating conditions. Contact NSK for details.
- User's manual and technical data are available for brake holding accuracy, operating time, and frequency of use. Contact NSK as necessary.

**Note on compliance with UL Standards and CE Mark**

- PN Series with Brake
- PN Series with brake does not comply with UL Standards or CE Mark.
- EDC Driver Unit
- EDC Driver Units comply with UL Standards and CE Mark when used with a Standard PN Series Megatorque Motor (without brake). However, they do not comply with UL Standards or CE Mark when used with a PN Series Megatorque Motor with a brake.

### 2.3.3 Rotational Speed and Output Torque Characteristics

PN3045

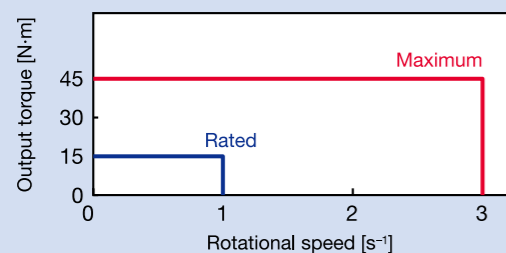

PN4135

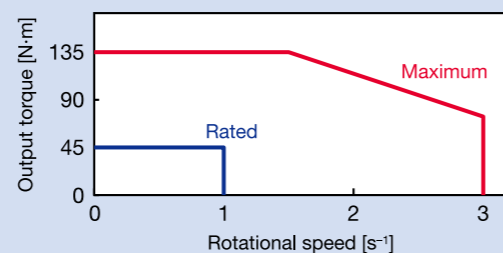

### 2.3.4 Motor Dimensions

M-PN3045KG001

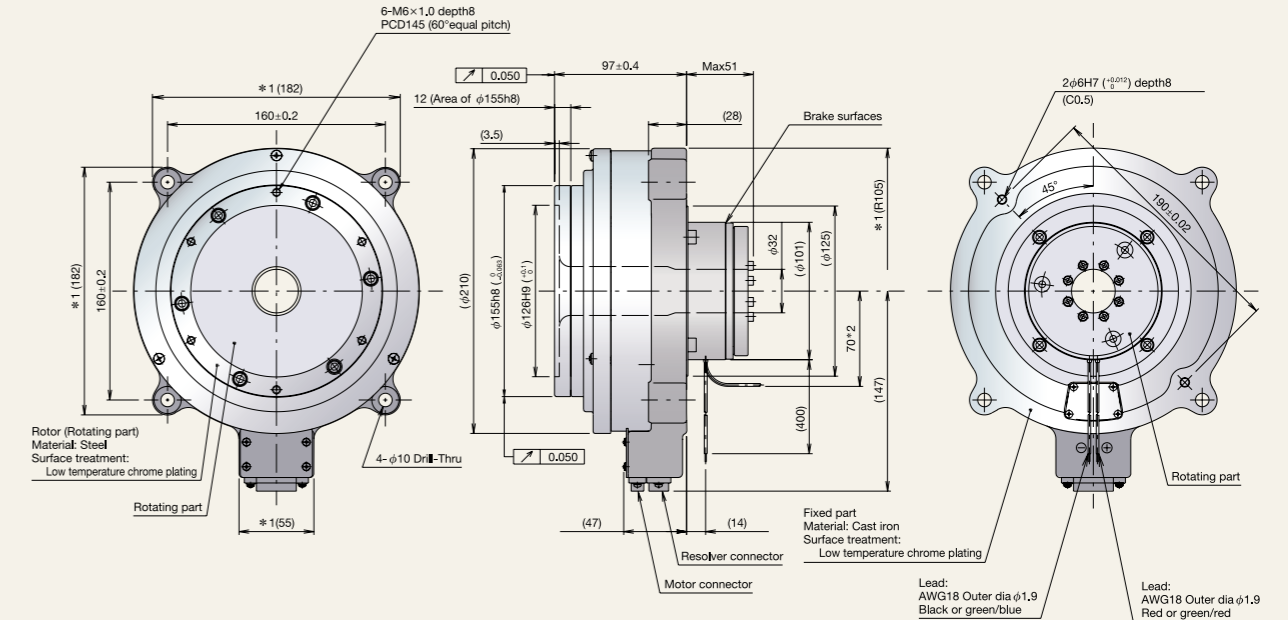

M-PN4135KG001

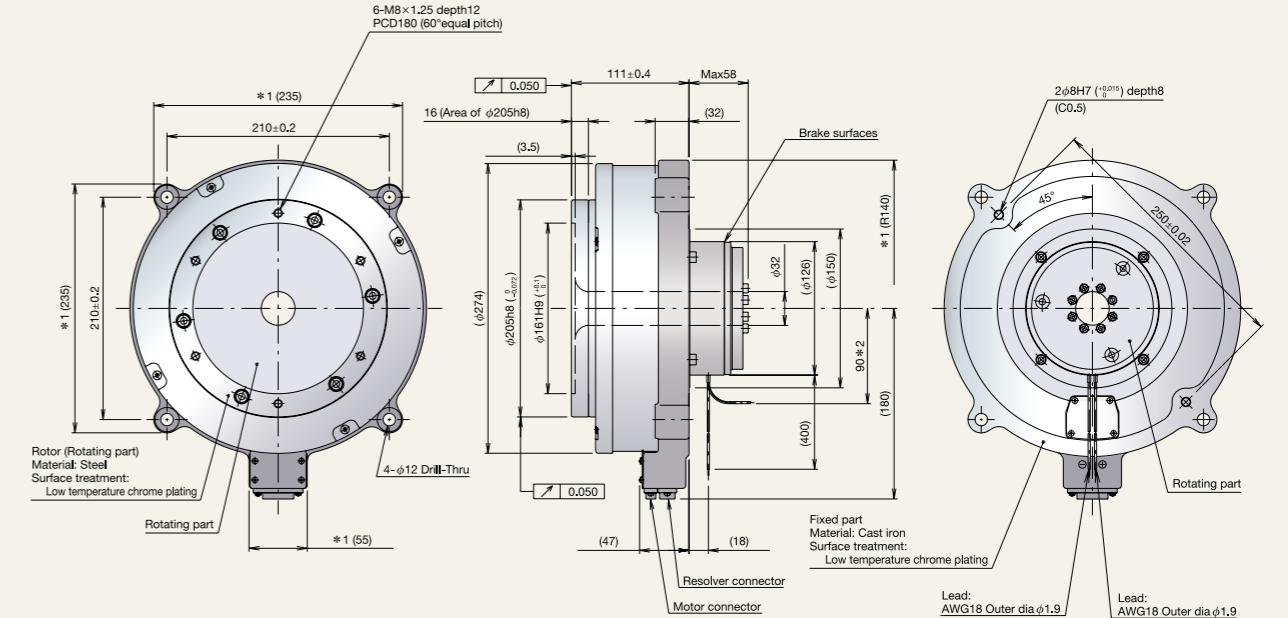

1. For the dimensions marked \*1, extra 3 [mm] margin is required due to their variations.
2. \*2 indicates the minimum lead bend distance. When bending the lead, maintain a greater distance than specified regardless of bend direction. The bend radius of leads should be at least R15 [mm].
3. Be sure to keep iron powders or oil away from brake surfaces.
4. Iron materials near a brake may interrupt operation; therefore allow for at least 15 [mm] clearance around the brake during installation.

## 2 Motor Specifications

### 2.4 Z Series with High Environmental Resistance

#### 2.4.1 Reference Number Coding of Motor

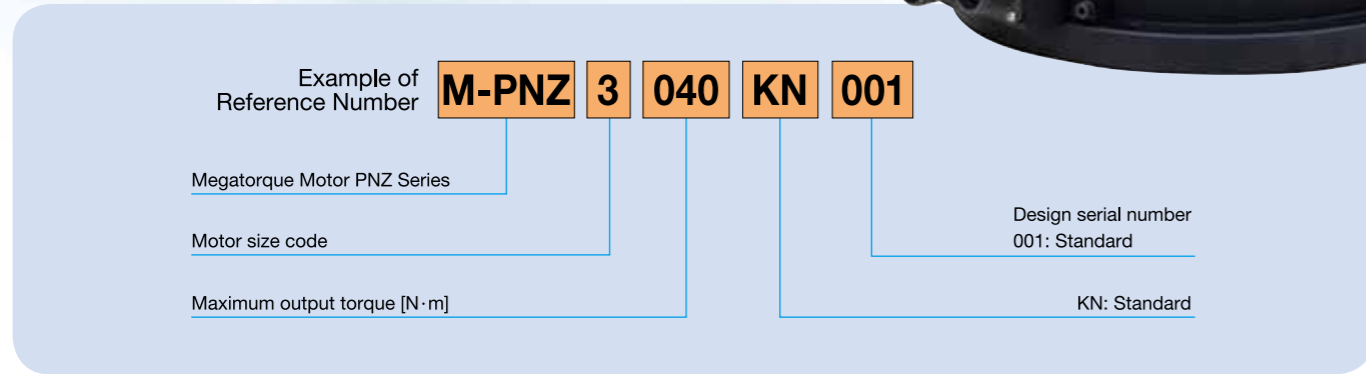

#### 2.4.2 Specifications

| Functional item                                  | Reference number | M-PNZ3040KN001   | M-PNZ4130KN001 | M-PNZ4175KN001 |
|--|------------------|--|----------------|----------------|
| Motor outer diameter [mm] (without flange)       |                  | φ220   | φ286           |                |
| Maximum output torque [N·m]                      |                  | 40   | 130            | 175            |
| Rated output torque [N·m]                        |                  | 5  | 30             | 45             |
| Motor height [mm]                                |                  | 100  | 120            | 137            |
| Motor hollow diameter [mm]                       |                  | φ44  | φ37            | φ37            |
| Maximum rotational speed [s <sup>-1</sup> ]      |                  |  | 3              |                |
| Rated rotational speed [s <sup>-1</sup> ]        |                  |  | 1              |                |
| Resolution of position sensor [count/revolution] |                  | 2 621 440  |                |                |
| Absolute positioning accuracy [arc-sec]          |                  | 90 (Interchangeable type) (at ambient temperature of 25 ± 5 [°C])      |                |                |
| Repeatability [arc-sec]                          |                  | ±2   |                |                |
| Allowable axial load [N]*1                       |                  | 4 500  | 9 500          |                |
| Allowable radial load [N]*2                      |                  | 4 500  | 9 500          |                |
| Allowable moment load [N·m]                      |                  | 80   | 160            | 200            |
| Rotor inertia [kg·m <sup>2</sup> ]               |                  | 0.028  | 0.12           | 0.13           |
| Allowable range of inertia [kg·m <sup>2</sup> ]  |                  | 0.11 to 0.77   | 0.57 to 3.99   | 0.65 to 4.55   |
| Mass [kg]  |                  | 21   | 42             | 48             |
| Environmental conditions                         |                  | Ambient temperature 0 to 40 [°C]; use indoors, free from corrosive gas |                |                |
| Degree of Protection                             |                  | IP66M (IEC/EN 60529, IEC/EN 60034-5)                                   |                |                |

- Please consult with NSK in case of a simultaneous application of axial load, radial load and moment load to a Motor.
- \*1 Under no radial load \*2 Under no axial load
- For an oscillating operation less than 45 [°], turn the Motor 90 [°] or more at least once a day.
- Please refer to 6.7 Effective Torque Calculations to calculate rated output torque during positioning operation.
- Conditions outside of the allowable range of inertia may be applicable, depending on operating conditions. Contact NSK for details.
- Dust and water resistance testing do not constitute a guarantee against malfunction or accident, or a guarantee of the product life. IP classifications specified by the IEC constitute indexes for protective performance under fixed conditions, and do not constitute a guarantee of ingress protection in all conditions and for all liquids and solids.
- Surface treatment for antirust is applied on the motor outer surface. However it does not mean that NSK guarantees antirust performance in any type of condition/environment. Please take measures protecting from rust on your own as needed basis. (NSK implemented neutral salt spray test for our surface treatment. Please contact NSK for details.)
- Sealing parts, such as oil seals, O-rings and gaskets for connector parts are made of nitrile rubber (NBR). Compatibility with the specific liquid to be used must be confirmed in advance. The operating temperature of the liquid should be 0 to 40 [°C]. Consult with NSK in advance to use the product in environments that it may be exposed to liquid, dust or particulates.
- The outer layer sheath of the cable set uses heat resistant PVC, which is not resistant to all types of liquid or oil. Consult with NSK in advance if you are concerned about a specific operating environment or liquids.
- Oil seals, O-rings, gaskets, and cables are consumable parts. Periodic inspection of sealing performance is strongly recommended to prevent motor failure or outage due to ingress of water. NSK replaces components, issues an overhaul evaluation report, and conducts performance inspections (excluding operations checking). Charges apply.
- Purge the air out of the oil seal section to ensure protection from ingress of water.
- Though rust may occur on the motor outer surface, it does not affect the motor performance.

**Note on compliance with UL Standards and CE Mark**

- Megatorque Motor Z Series with High Environmental Resistance
- Megatorque Motor Z Series with High Environmental Resistance does not comply with UL Standards or CE Mark.
- EDC Driver Unit
- EDC Driver Units comply with UL Standards and CE Mark when used with a standard PN Series Megatorque Motor. However, they do not comply with UL Standards or CE Mark when used with a Megatorque Motor Z Series with High Environmental Resistance.

#### 2.4.3 Rotational Speed and Output Torque Characteristics

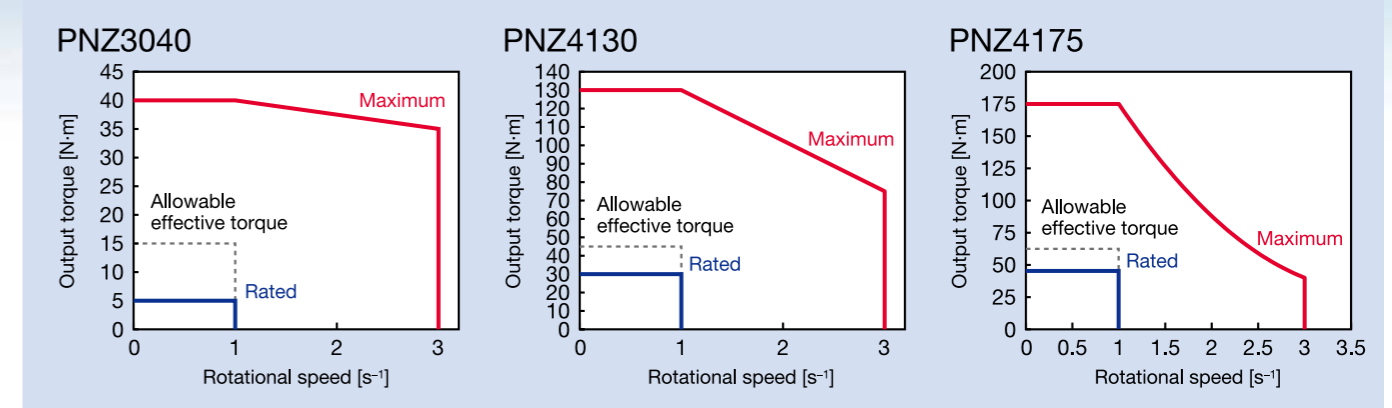

Please refer to 6.7 Effective Torque Calculations to calculate allowable effective torque during positioning operation.

#### 2.4.4 Dimensions

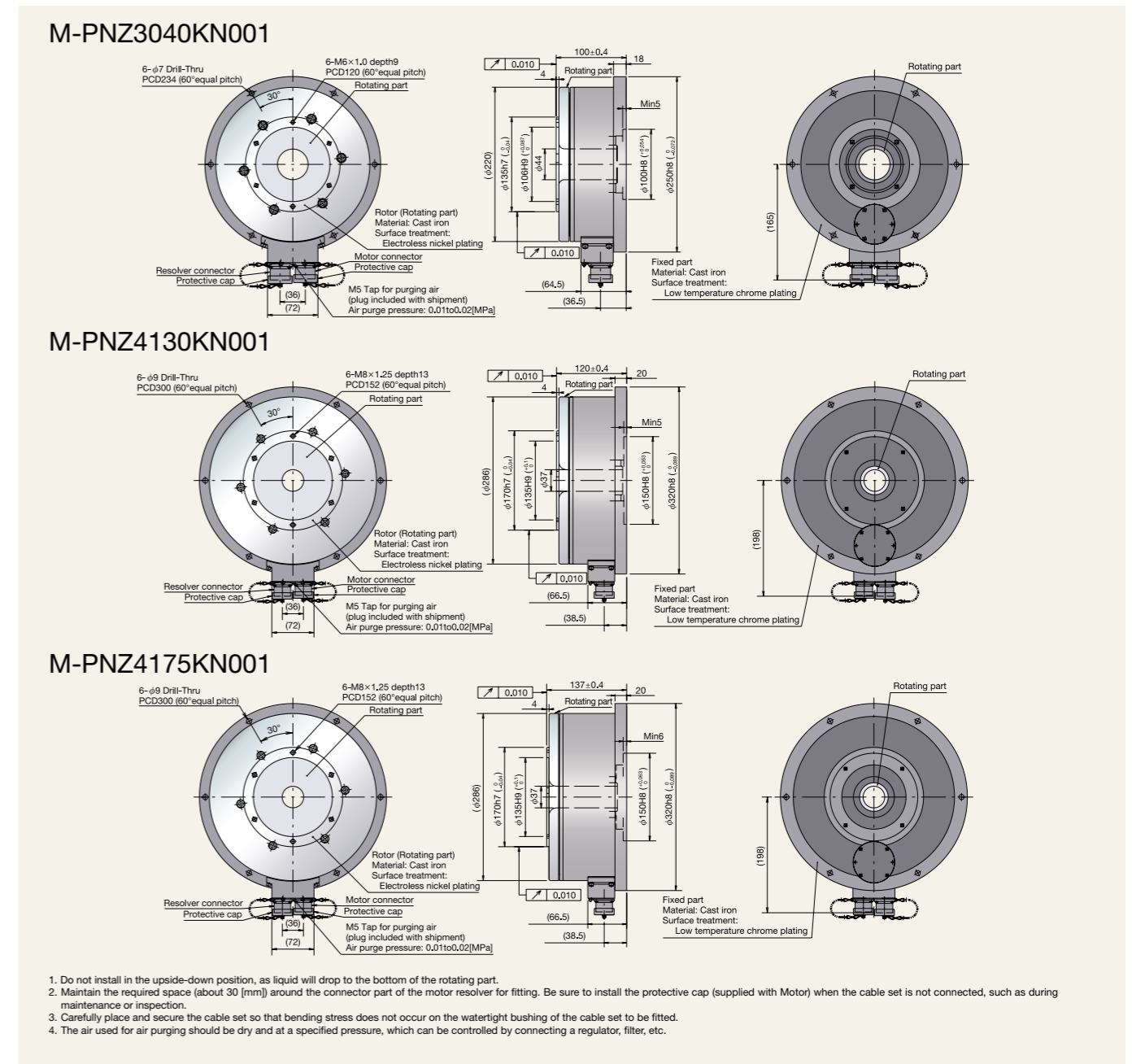

# 3 EDC Driver Unit

## 3.1 Features of EDC Driver Unit

- Adopts new servo algorithm (achieves settling time of 1 [ms])**  
 The EDC Driver Unit adopts an original disturbance observer and preview-based feed-forward control, which significantly reduces the positioning time, especially the settling time (approaching time).
- Positioning controller function**  
 Positioning operation can be controlled without complicated communication or upper controller.
- Compact Driver Unit**  
 Combined with special electric components and advanced integration technology, the Driver Unit body is 65% smaller than conventional NSK units.
- Variety of control I/Os**  
 Control input/output required for positioning is available, including an encoder output, servo control and program control; no additional sensor is required to monitor the status.

## 3.2 Components and functions of EDC Driver Unit

- Rear mounting hole**  
 Optional mounting bracket available for front mounting.
- 7 segment LEDs indicator**  
 Driver Unit status can be recognized at a glance.
- Analog monitor output terminal**  
 Speed, positioning error, torque, motor current, etc. can be monitored by analog voltage. Effectively used for set up tuning or for monitoring operating status.
- RS-232C communication connector**  
 Connect the handy terminal to set parameters. Use the EDC Megatorm software to communicate with a PC.
- Control I/O connector**  
 A variety of signals are available, including servo on, in-position, emergency stop, area signal, override, various alarm outputs,  $\phi A/\phi B/\phi Z$ , etc.
- Independent inputs of main power and control power**  
 Separate power lines assure system safety.
- Motor cable connector**  
 Clamping type connector shortens work time and prevents mis-wiring.

## 3.3 Control Technology and System Configuration of EDC Driver Unit

### Control Technology and High-speed Positioning Example

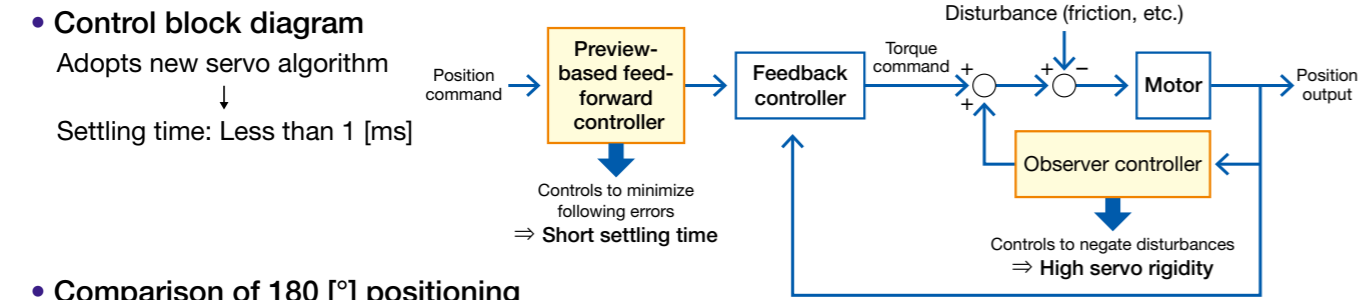

### Comparison of 180 [°] positioning

Positioning time = Command time + Settling time

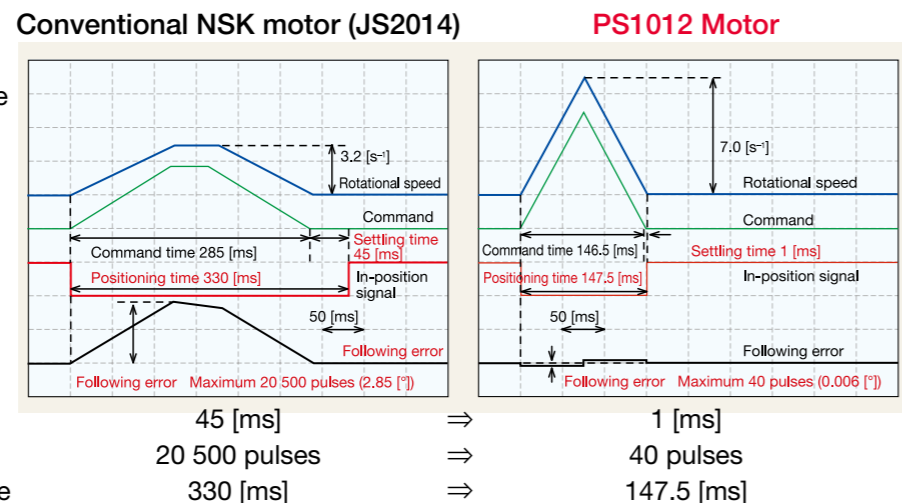

## System Configuration of PS/PN Series and Z Series with High Environmental Resistance

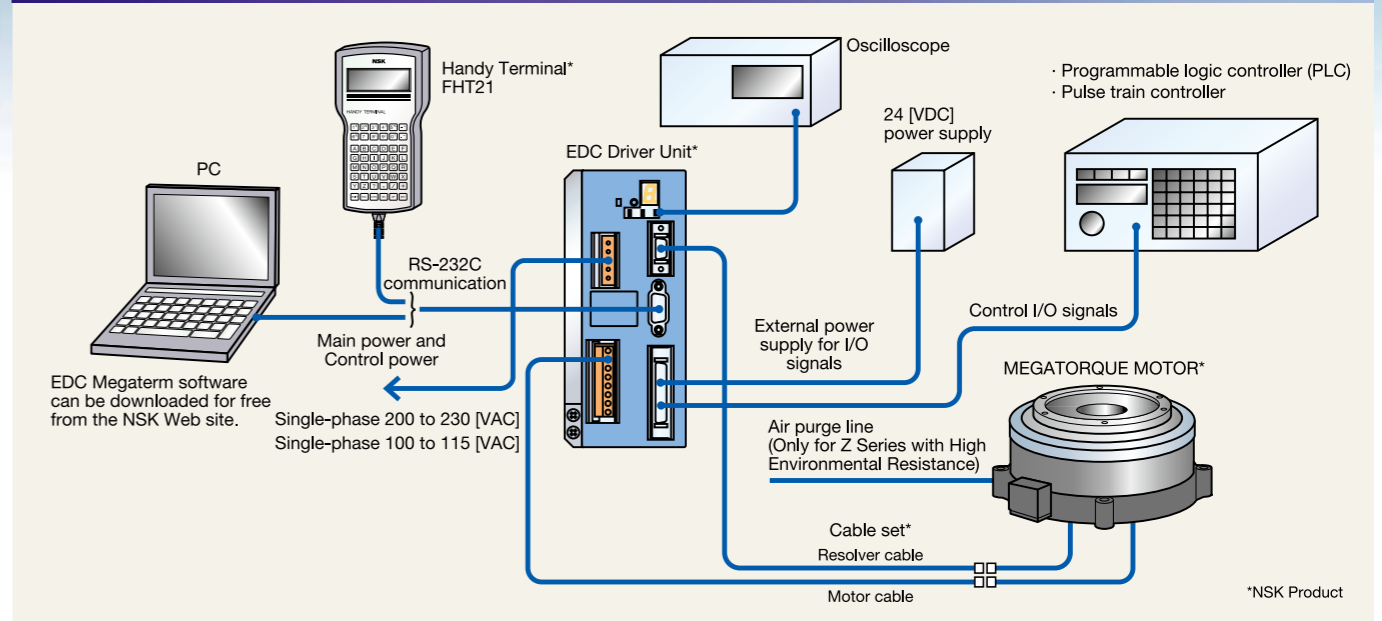

## System Configuration of PN Series with Brake

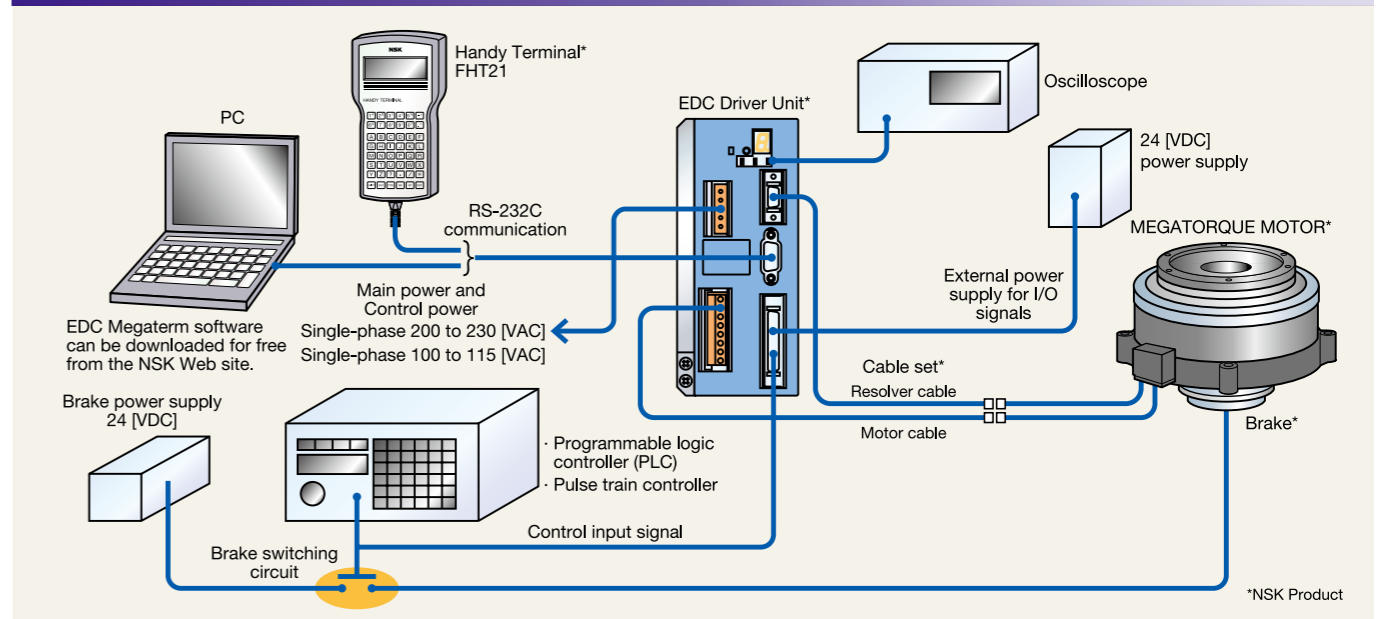

## 3.4 Example of Brake Sequence

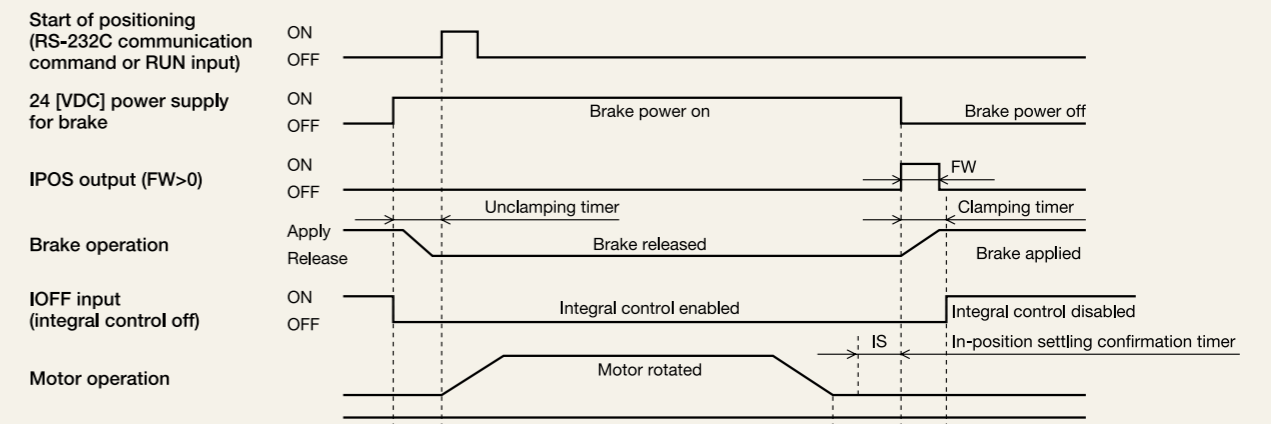

Figure: Brake sequence operation timing (while motor is rotating)

For brake sequence details, refer to the User's Manual.

### 3 EDC Driver Units



#### 3.5 EDC Driver Unit Reference Number

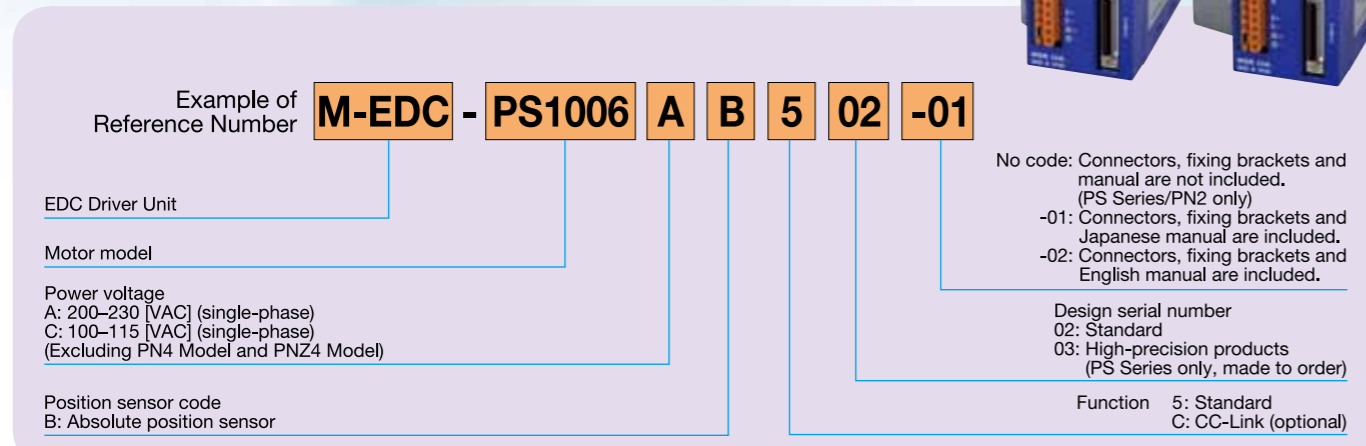

EDC Driver Unit for Z Series with High Environmental Resistance is the same unit used with the PN Series. Refer to 9. Motor and EDC Driver Unit Combinations for details of applicable models.

Accessories vary depending on the function.

#### Standard accessories

- CN2 connector (user side)  
Connector: 54306-5019 (Molex), or equivalent Connector shell: 54331-0501 (Molex), or equivalent
- CN5 connector (user side)  
Connector: 231-305/026-000 (WAGO), or equivalent Wiring lever: 231-131(WAGO), or equivalent
- Mounting bracket
- User's Manual (English version)

#### Accessories for EDC Driver Unit (CC-Link Function)

- CN2 connector (user side)  
Connector: DHF-PDA10-3-A01-FA (DDK), or equivalent
- CN5 connector (user side)  
Connector: 231-305/026-000 (WAGO), or equivalent Wiring lever: 231-131 (WAGO), or equivalent
- CN6 connector (user side)  
Connector: MSTB, 5/5-STF-5, 08AU (Phoenix contact), or equivalent
- Mounting bracket
- User's Manual (English version)
- User's Manual for CC-Link (English version)

#### 3.6 Dimensions of EDC Driver Unit (Standard Function)

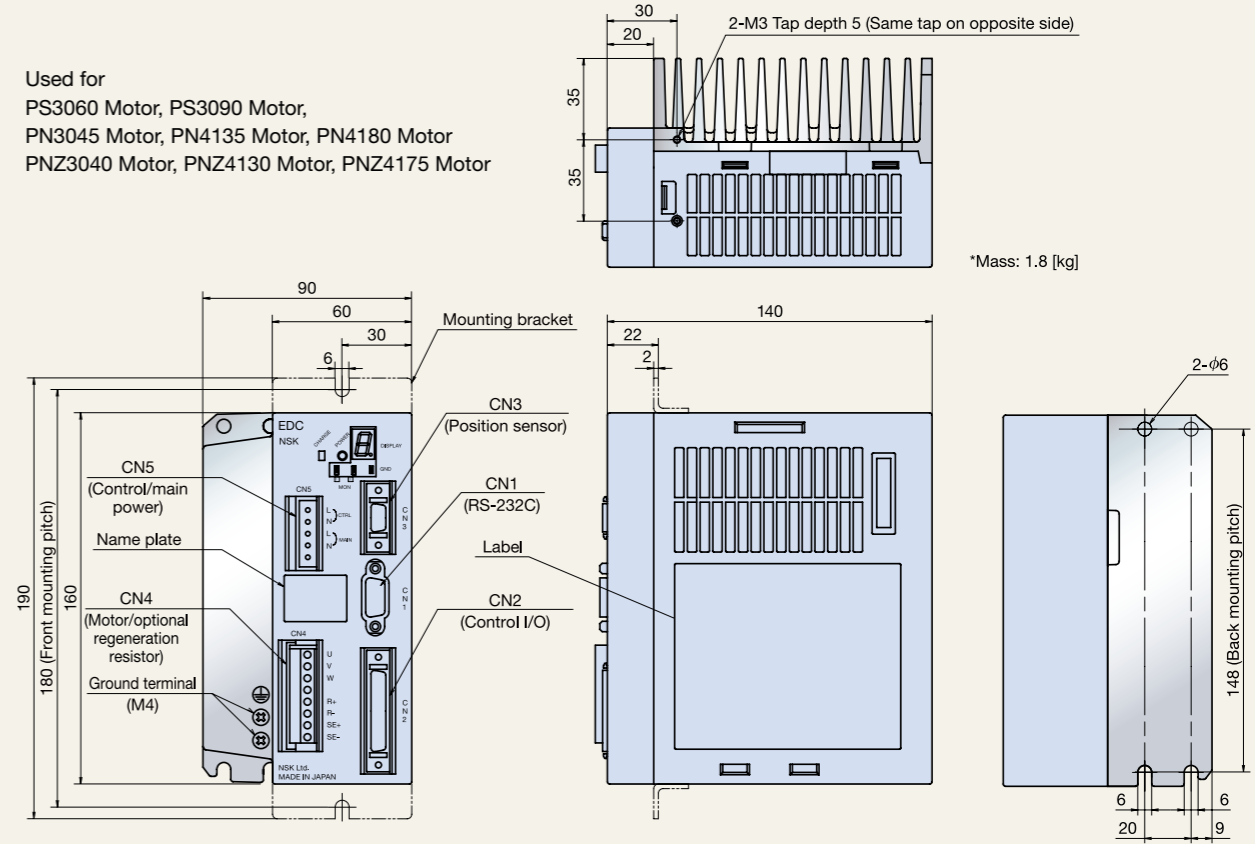
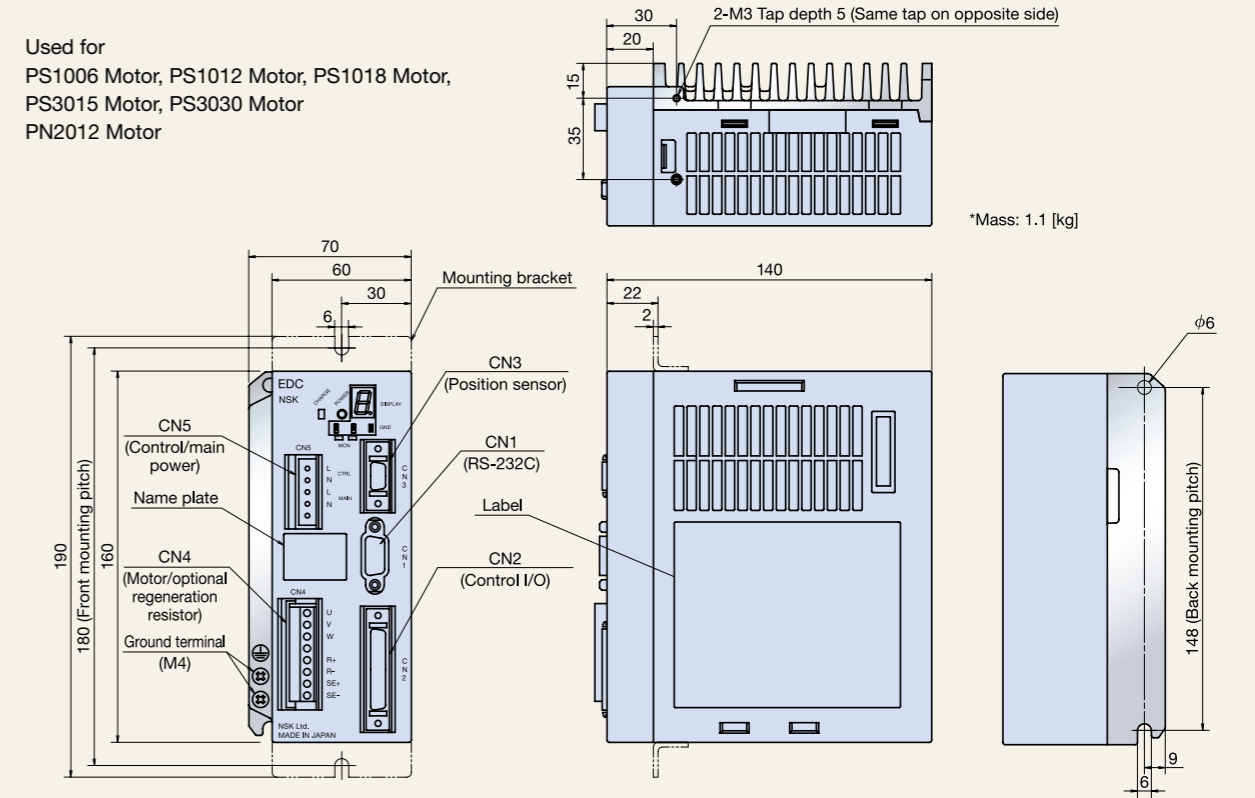

3.7 General Specifications of EDC Driver Unit

| Item   | Motor model                    | PS1006   | PS1012  | PS1018 | PS3015 | PS3030 | PS3060 | PS3090                                   | PN2012 | PN3045 | PN4135 | PN4180 |  |
|--|--------------------------------|--|---|--------|--------|--------|--------|--|--------|--------|--------|--------|--|
| Input power                                      | Rated capacity [VA]            | 300  | 400   | 500    | 500    | 800    | 400    | 600                                      | 100    | 500    | 900    | 1100   |  |
|  | Maximum capacity [VA]          | 1 000  | 1 500   | 2 000  | 2 300  | 2 900  | 5 000  | 5 500                                    | 2 100  | 4400   | 5 000  | 5 100  |  |
|  | Control power source           | Single phase 100 to 115 [VAC]/single phase 200 to 230 [VAC] 50/60 [Hz]   |   |        |        |        |        | Single phase 200 to 230 [VAC] 50/60 [Hz] |        |        |        |        |  |
|  | Main power                     | Voltage fluctuation ±10% or less   |   |        |        |        |        | Voltage fluctuation ±10% or less         |        |        |        |        |  |
| Resolution of position sensor [count/revolution] |                                | 2 621 440  |   |        |        |        |        |  |        |        |        |        |  |
| Positioning operation mode                       |                                | Program operation (up to 256 Program channels: Position commands and parameter settings are programmable) Pulse train command, RS-232C serial communication command, Jogging, Home Return  |   |        |        |        |        |  |        |        |        |        |  |
| Input signal                                     | Pulse train command            | Photocoupler input. Maximum frequency: 1 [MHz]<br>Input format: CW/CCW, Pulse and direction or φA/φB<br>Resolution changer for universal multiplication is available (1 000 to 5 242 880 [count/revolution])   |   |        |        |        |        |  |        |        |        |        |  |
|  | Control input                  | Opto-coupler input (± common), 17 input ports (Input voltage: 24 [VDC])<br>Emergency stop, Alarm clear, Over travel limit (+ direction), Over travel limit (- direction), Servo on, Program operation start, Stop, Internal program channel switching 0-7 bit, Jog, Jog direction, (Hold, Velocity, integration OFF, Home Return start, and Home position limit)   |   |        |        |        |        |  |        |        |        |        |  |
| Output signal                                    | Position feedback signal       | Signal format: φA/φB/φZ line driver. Universal resolution setting to φA/φB is available.<br>Resolution of φA/φB: Shipping set: 20 480 [count/revolution] (Quadrupled: 81 920)<br>Maximum: 1 310 720 [count/revolution] (Quadrupled: 5 242 880)<br>*As the maximum frequency is 781 [kHz], the resolution setting limits the maximum velocity.  |   |        |        |        |        |  |        |        |        |        |  |
|  | Control output                 | Photocoupler output (± common), 8 outputs (Max. switching capacity: 24 [VDC] / 50 [mA])<br>Driver Unit ready, Warning, Over travel limit detection (± direction), Servo state, Busy, In-position, Target proximity A (Target proximity B), Zone A/B/C, Travel limit ±, Normal, Position error under/over, Velocity under/over, Torque command under/over, Thermal loading under/over, Home return complete, Home position defined  |   |        |        |        |        |  |        |        |        |        |  |
| Alarms   |                                | RAM error, ROM error, System error, Interface error, ADC error, Emergency stop, CPU error, Position sensor error, Absolute position error, Motor cable disconnect, Excessive velocity, Resolver excitation amplifier alarm, Commutation error, Overheat, Main AC Line over voltage, Excess current, Control AC line under voltage, Power module alarm, Excess position error, Program error, Automatic tuning error, Position command/feedback error, Software thermal error, Main AC Line under voltage, Travel limit over, Field bus warning, Home position undefined, Field bus error |   |        |        |        |        |  |        |        |        |        |  |
| Monitors   |                                | Analog monitor x 2, (universal range and offset setting), RS-232C monitor  |   |        |        |        |        |  |        |        |        |        |  |
| Communication                                    |                                | RS-232C serial communication (asynchronous, 9 600 [bps])   |   |        |        |        |        |  |        |        |        |        |  |
| Others   |                                | Automatic tuning<br>Function set to Input/output ports available<br>Temporal parameter setting by program is available<br>Individual acceleration/deceleration setting<br>Acceleration profiling   |   |        |        |        |        |  |        |        |        |        |  |
| Option   |                                | Field bus (CC-Link)  |   |        |        |        |        |  |        |        |        |        |  |
| Environmental conditions                         | Operating/Storing temperatures | 0 to 50 [°C] for operating / -20 to +70 [°C] for storing   |   |        |        |        |        |  |        |        |        |        |  |
|  | Operating/Storing humidity     | 90% or less [no condensation]  |   |        |        |        |        |  |        |        |        |        |  |
|  | Vibration resistance           | 4.9 [m/s <sup>2</sup> ] or less  |   |        |        |        |        |  |        |        |        |        |  |
| Internal functions                               | Regenerative energy absorption | Optional regeneration resistor   |   |        |        |        |        |  |        |        |        |        |  |
|  | Dynamic brake                  | Functions at power off, servo off and in the occurrence of an alarm.   |   |        |        |        |        |  |        |        |        |        |  |
| Compatible safety regulation                     | UL                             | UL508C   |   |        |        |        |        |  |        |        |        |        |  |
|  | CE                             | LVD  | EN50178   |        |        |        |        |  |        |        |        |        |  |
|  |                                | EMC  | EMI: EN55011, EMS: EN61000-6-2  |        |        |        |        |  |        |        |        |        |  |
| Connector  | RS-232C                        | CN1  | D-sub 9 pins  |        |        |        |        |  |        |        |        |        |  |
|  | Control I/O                    | CN2  | Standard: Half pitch connector 50 pins<br>CC-Link: Half pitch connector 10 pins |        |        |        |        |  |        |        |        |        |  |
|  | Position sensor                | CN3  | Half-pitch connector 14 pins  |        |        |        |        |  |        |        |        |        |  |
|  | Motor                          | CN4  | Plastic connector (UL and CE compatible)  |        |        |        |        |  |        |        |        |        |  |
|  | Optional regeneration resistor |  |   |        |        |        |        |  |        |        |        |        |  |
|  | Main/control power source      | CN5  | Plastic connector (UL and CE compatible)  |        |        |        |        |  |        |        |        |        |  |
| CC-Link (option)                                 | CN6                            | Connector MSTB2, 5/5-STF-5, 08 AU (Phoenix contact)  |   |        |        |        |        |  |        |        |        |        |  |

3.8 Signal Specifications of CN2 (Control I/O)

| Input Output | Signal Code   | Pin No.          | Signal Name                              | Function  |
|--------------|---------------|------------------|--|---|
| Input signal | DC24          | 1, 2             | 24 [VDC] external power supply           | External power supply for input signal  |
|              | EMST          | 3                | Emergency stop                           | Terminates positioning operation and the Motor stops by the dynamic brake   |
|              | ACLR          | 4                | Alarm clear                              | Clears warning <sup>*1</sup>  |
|              | OTP           | 5                | Over travel limit (+ direction)          | If OTP goes active, the Motor servo is locked in the CW direction <sup>*1</sup>   |
|              | OTM           | 6                | Over travel limit (- direction)          | If OTM goes active, the Motor servo is locked in the CCW direction <sup>*1</sup>  |
|              | SVON          | 7                | Servo on                                 | If SVON goes active, the servo turns on and the system waits for a command to be entered <sup>*1</sup>                              |
|              | RUN           | 8                | Start program                            | Starts program operation specified by the PRG input <sup>*1</sup>   |
|              | STP           | 9                | Stop                                     | Stops positioning operation and execution of the program <sup>*1</sup>  |
|              | —             | 10               | (Do not connect)                         | —   |
|              | PRG0          | 11               | Internal program channel selection 0     | For a program positioning operation: A combination of ON and OFF of PRG0 to PRG7 inputs specifies channel (0 to 255) to be executed |
|              | PRG1          | 12               | Internal program channel selection 1     |   |
|              | PRG2          | 13               | Internal program channel selection 2     |   |
|              | PRG3          | 14               | Internal program channel selection 3     |   |
|              | PRG4          | 15               | Internal program channel selection 4     |   |
|              | PRG5          | 16               | Internal program channel selection 5     |   |
|              | PRG6          | 17               | Internal program channel selection 6     |   |
|              | PRG7          | 18               | Internal program channel selection 7     |   |
|              | JOG           | 19               | Jogging                                  | If JOG goes active, the Motor rotates. If it goes inactive, the Motor decelerates and stops <sup>*1</sup>                           |
|              | DIR           | 20               | Jogging direction                        | Specifies the direction of jogging <sup>*1</sup>  |
|              | —             | 21               | (Do not connect)                         | —   |
|              | CWP+          | 22               | CW pulse train (+)                       | Pulse train command rotates the Motor in the CW direction   |
|              | CWP-          | 23               | CW pulse train (-)                       |   |
|              | CCWP+         | 24               | CCW pulse train (+)                      | Pulse train command rotates the Motor in the CCW direction  |
|              | CCWP-         | 25               | CCW pulse train (-)                      |   |
|              | Output signal | COM              | 26, 27                                   | Output signal common  |
| DRDY         |               | 28               | Driver Unit ready                        | Reports that the Motor is ready to rotate (The port opens when the Motor is not ready or an alarm occurs)                           |
| WRN          |               | 29               | Warning                                  | Warns of abnormality in the System <sup>*2</sup>  |
| OTPA         |               | 30               | Over travel limit (+ direction) detected | Reports the output of over travel limit (software and hardware) in the plus direction <sup>*2</sup>                                 |
| OTMA         |               | 31               | Over travel limit (- direction) detected | Reports the output of over travel limit (software and hardware) in the minus direction <sup>*2</sup>                                |
| SVST         |               | 32               | Servo state                              | Reports states of servo <sup>*2</sup>   |
| BUSY         |               | 33               | In-operation                             | Reports state of positioning operation <sup>*2</sup>  |
| IPOS         |               | 34               | In-position                              | Reports the condition of positioning error and the positioning operation <sup>*2</sup>  |
| NEARA        |               | 35               | Target proximity A                       | Reports that the Motor is approaching the destination <sup>*2</sup>   |
| CHA          |               | 36               | Positioning feedback signal φA           | A pulse signal that reports the number of rotations of Motors<br>Output format is line driver                                       |
| *CHA         |               | 37               | Positioning feedback signal *φA          |   |
| CHB          |               | 38               | Positioning feedback signal φB           |   |
| *CHB         |               | 39               | Positioning feedback signal *φB          |   |
| CHZ          |               | 40               | Positioning feedback signal φZ           |   |
| *CHZ         |               | 41               | Positioning feedback signal *φZ          |   |
| —            | 42            | (Do not connect) | —  |   |
| SGND         | 43            | Signal ground    | Ground for the position feedback signal  |   |
| —            | 44 to 50      | (Do not connect) | —  |   |

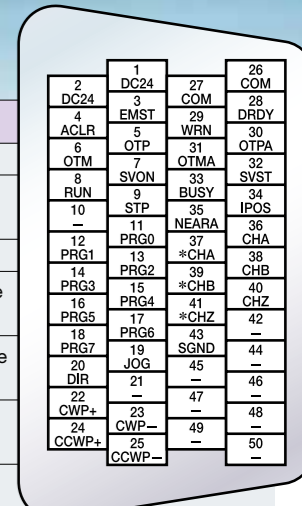

Carefully follow these instructions for wiring to CN2.

- When wiring to CN2, use shielded wires and a twisted pair for a pulse train input and position feedback output. These wires should be as short as possible (up to 2 [m]).

Selection and optional setting of control Input/Output signal functions

- You may set signal functions of control Input/Output to any port by the parameters.

<sup>\*1</sup> Input signal

- Select up to 16 input signals out of the 22 input signals listed above and then set them to Pin No. 4 to 9 and 11 to 20. (In addition to the Input signals listed above, you may select any of the following signals: Hold, Velocity override, Integration OFF, Home return start, and Home position limit.)
- Pin No. 3 is fixed to the "Emergency stop" signal. (The signal polarity is variable.)

<sup>\*2</sup> Output signal

- Select up to 7 output signals out of the 23 output signals listed above and then assign them to Pin No. 29 to 35. In addition to the Output signals listed above, you may select any of the following signals: Target proximity B, Zone A/B/C, Over travel limit (± direction), Normal, Position error (under/over), Velocity (under/over), Torque command (under/over), Thermal loading (under/over), Home return completed, and Home position defined.
- The output "Driver Unit ready" set to Pin No. 28 can only be replaced with the output signal "Normal." (Signal polarity cannot be changed.)

# 4 Cable Set

## 4.1 Cable Set Reference Number

Cable Set Reference Number for PS/PN Series and PN Series with Brake

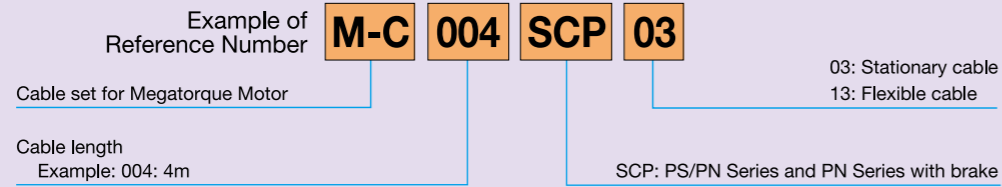

Refer to 9 Motor and EDC Driver Unit Combinations for correct length.  
 Cable length has to be less than 8 [m] for combinations with PN2012 and high-precision products in PS series.

Cable Set Reference Number for Z Series with High Environmental Resistance

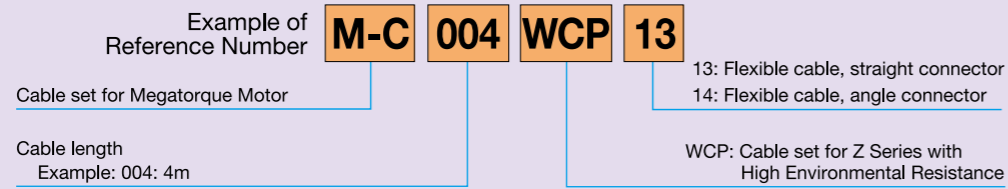

Refer to 9. Motor and EDC Driver Unit Combinations for correct length.

## 4.2 Dimension of Cable Set

Cable Set Dimensions for PS/PN Series and PN Series with Brake

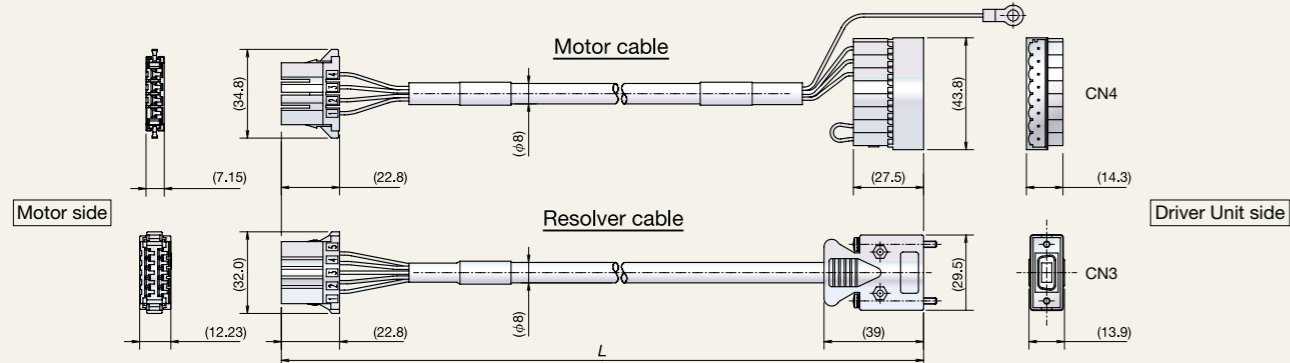

Cable Set Dimensions for Z Series with High Environmental Resistance

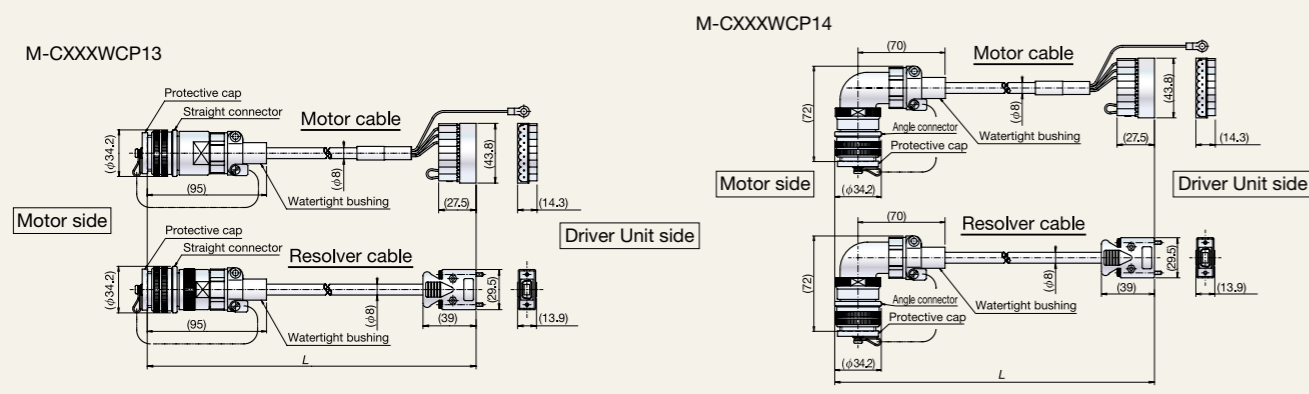

Cable bend radius (for both motor cable and resolver cable)

|                  | Bend radius at fixed side | Bend radius at moving side |
|------------------|---------------------------|----------------------------|
| Stationary cable | R43 or more               | —                          |
| Flexible cable   | R40 or more               | R80 or more                |

# 5 Option

## 5.1 EDC Driver Unit with CC-Link Function

### 5.1.1 System Configuration

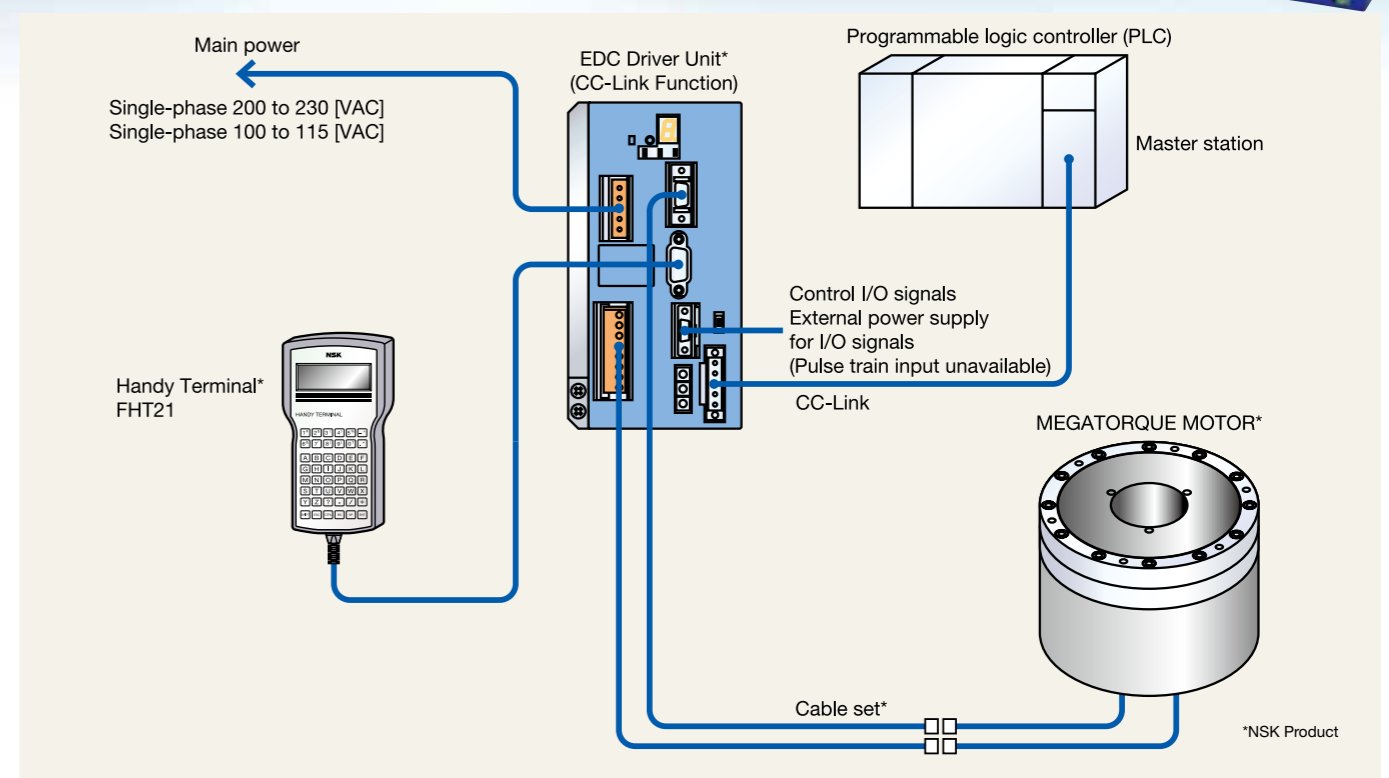

- The EDC Driver Unit provides the field bus (CC-Link) compatibility.
- The station numbers and the baud rate can be set by switches on the Driver Unit's front panel.
- Monitoring communication status by LED, and terminating resistor can be switched on/off.
- The EDC Driver Units are fully compatible with CC-Link Ver. 1.10.

### 5.1.2 I/O Signal Specifications of CN2 (CC-Link Function)

| Input/Output  | Signal Code | Pin No. | Cable Color            | Signal Name                     | Function  |
|---------------|-------------|---------|------------------------|---------------------------------|---|
| Input signal  | DC24        | 1       | Orange with red dots   | 24 [VDC] external power supply  | External power supply for input signal  |
|               | —           | 2       |                        | (Do not connect)                | —   |
|               | EMST        | 3       | Grey with red dots     | Emergency stop                  | Terminates positioning operation and the Motor stops by the dynamic brake                                     |
|               | ACLR        | 4       | Grey with black dots   | Clear warning                   |   |
|               | OTP         | 5       | White with red dots    | Over travel limit (+ direction) | If OTP goes active, the Motor servo is locked in the CW direction   |
|               | OTM         | 6       | White with black dots  | Over travel limit (- direction) | If OTM goes active, the Motor servo is locked in the CCW direction  |
|               | —           | 7       |                        | (Do not connect)                | —   |
| Output signal | DRDY        | 8       | Yellow with black dots | Driver Unit ready               | Reports that the Motor is ready to rotate (pins are open when the Motor is not ready or when an alarm occurs) |
|               | —           | 9       |                        | (Do not connect)                | —   |
|               | COM         | 10      | Pink with black dots   | Output signal common            | Common for output signal  |

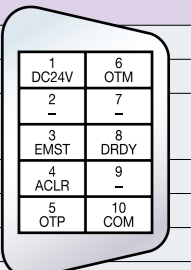

Specifications of Driver Units, except CN2, are the same as standard products (refer to page 24).

Cable with CN2 connector (optional)  
 Reference number: M-E011DCCN1-001

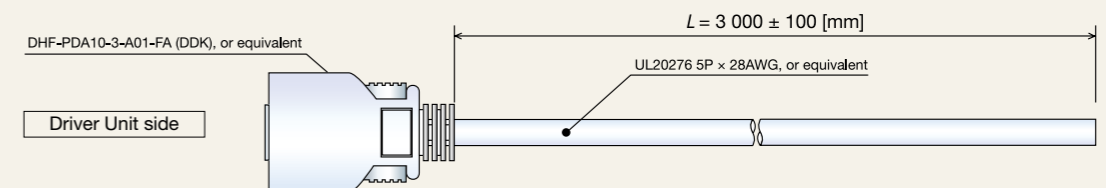

5.1.3 Dimensions of EDC Driver Unit (CC-Link Function)

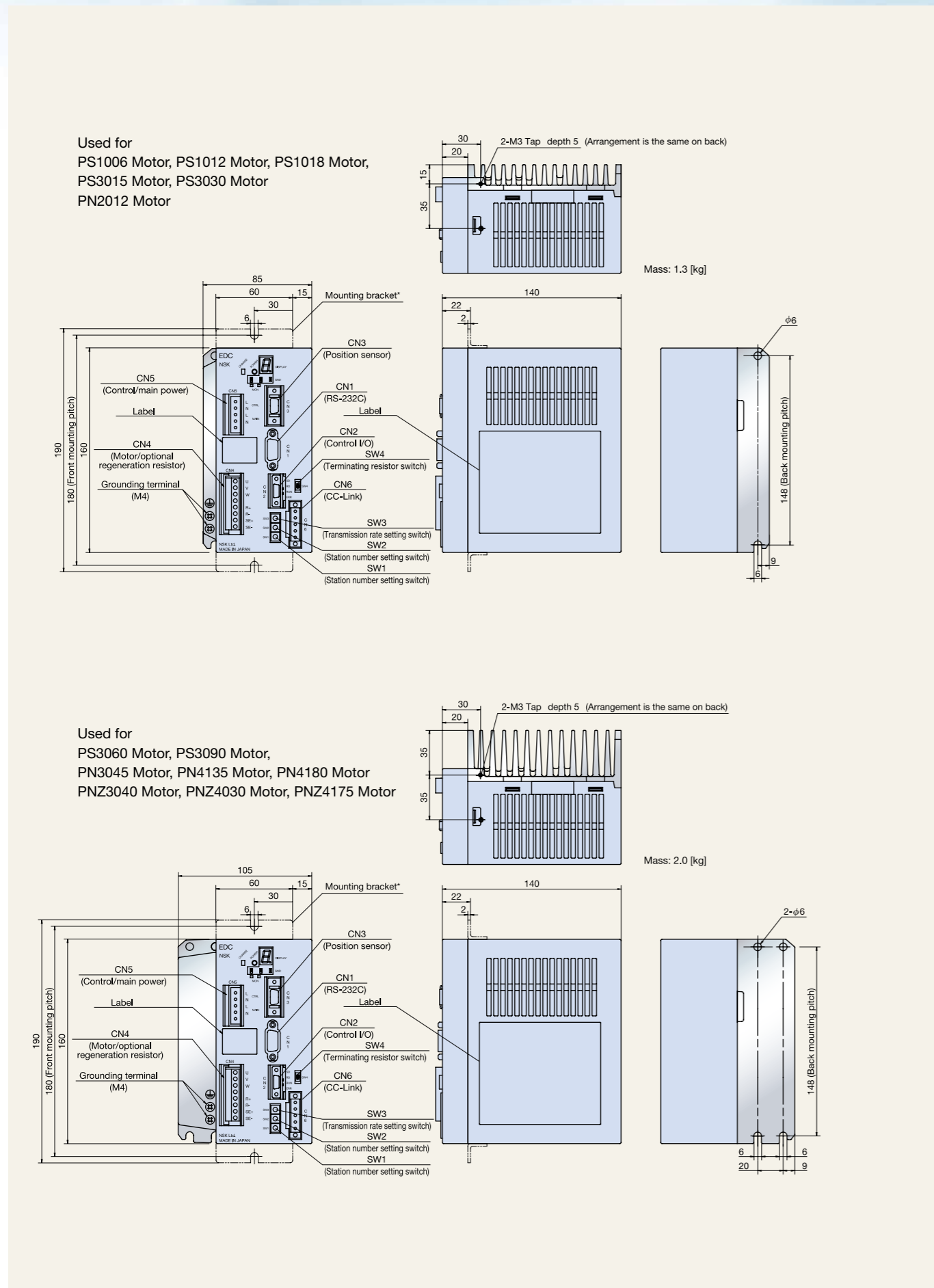

5.2 Optional Regeneration Resistor (M-E014DCKR1-100·101)

5.2.1 Dimensions and Schematics

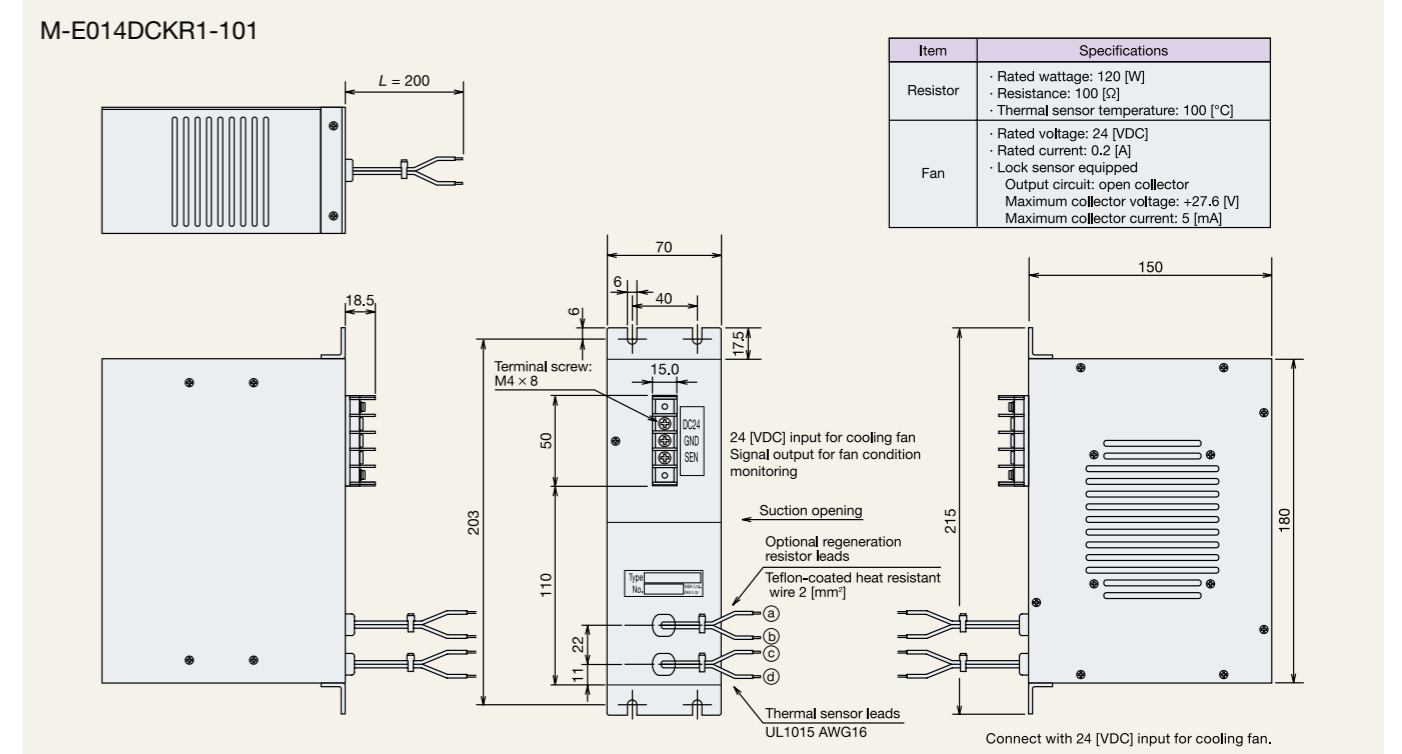
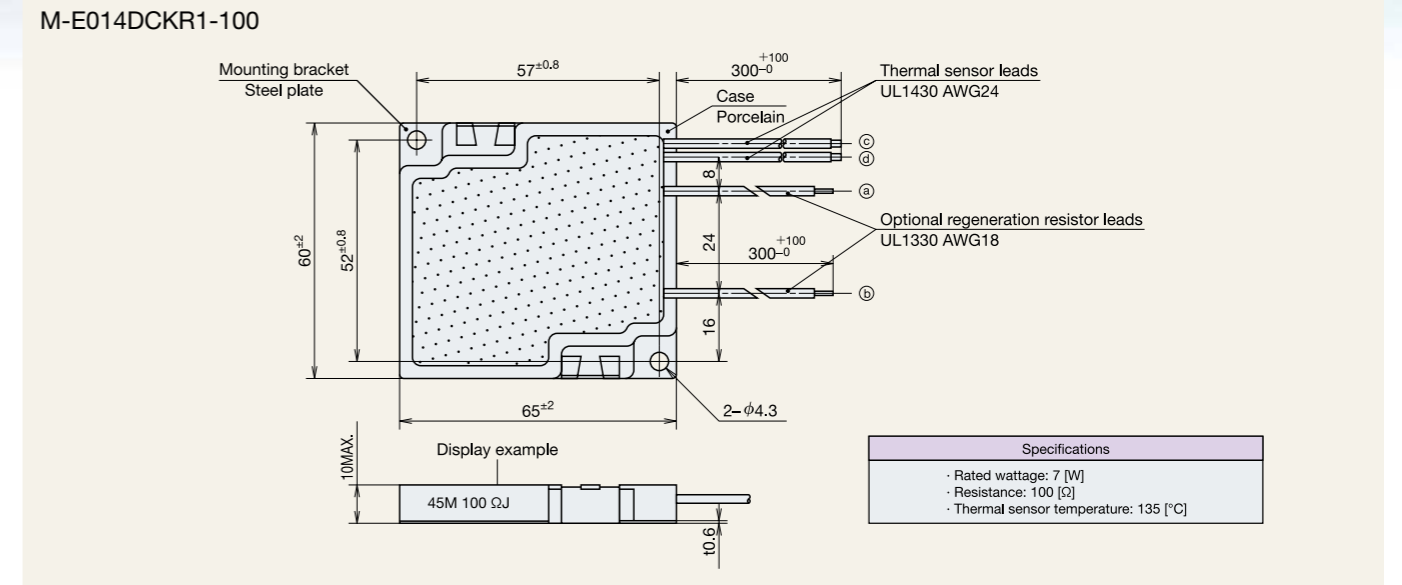

5.2.2 Connection to EDC Driver Unit

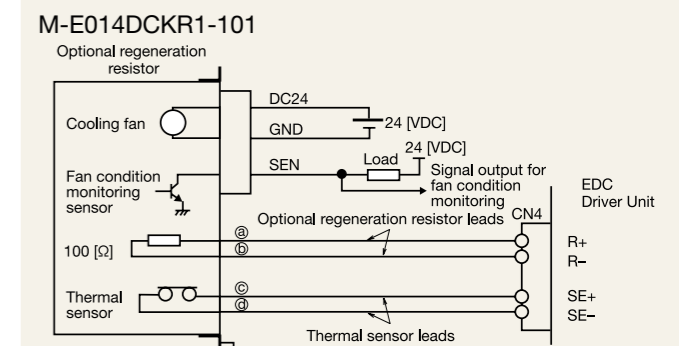
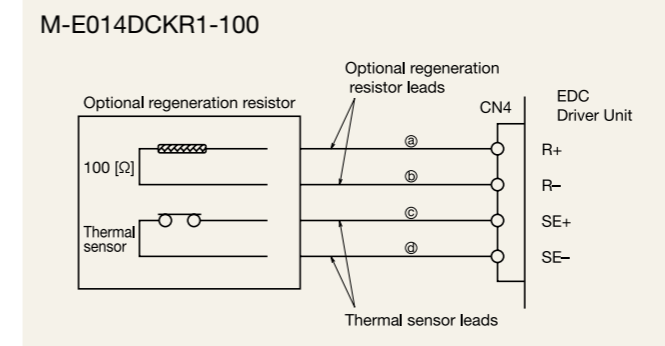

### 5.3 Handy Terminal

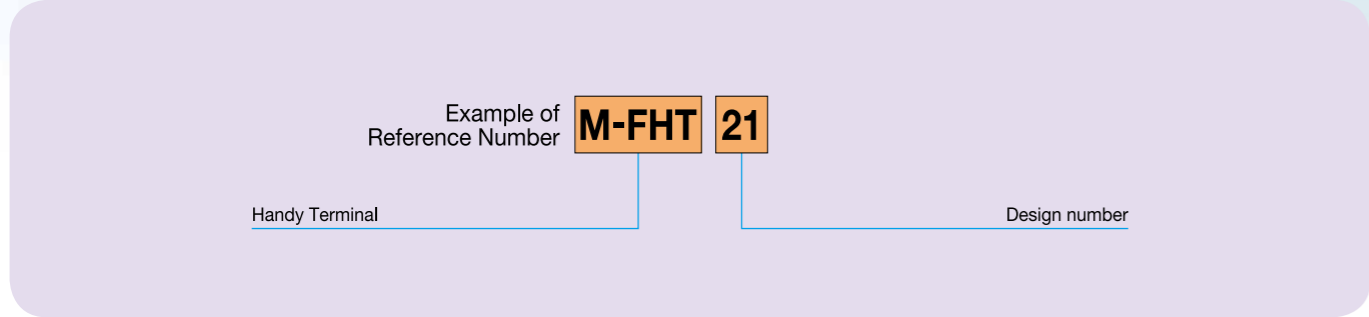

Handy Terminal FHT21 is an easy-to-handle RS-232C communication terminal for inputting parameters and programs to the EDC Driver Unit. The device can also read and save (upload) driver unit parameters and channel programs, and transmit (download) them to other driver units.



- LCD screen: 20 letters × 4 lines, no external power source required, cable length: 3 [m]

Conventional model M-FHT11 is also supported by the EDC Driver Unit.

### 5.4 RS-232C Communication Cable

(Communication cable between EDC Driver Unit and PC)

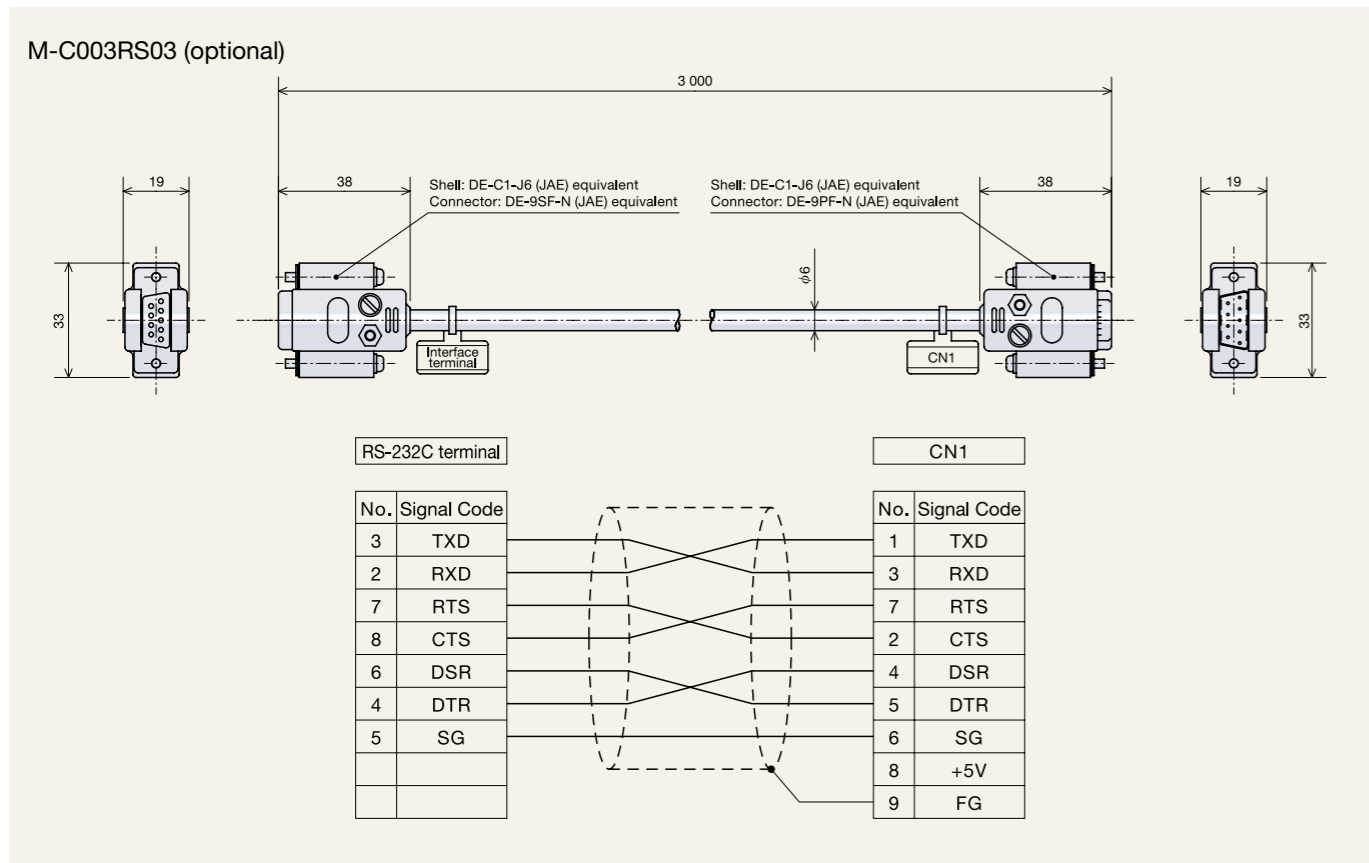

## 6 Selection of Megatorque Motors

To select appropriate Megatorque Motors, examine the following data.

- 6.1 Loads on the Motor ((1) Load moment of inertia; (2) Axial load, radial load, and moment load; (3) Holding torque required during halts)
- 6.2 Runout Accuracy
- 6.3 Positioning Accuracy
- 6.4 Positioning Time (Index Time)
- 6.5 Selection of Optional Regeneration Resistor
- 6.6 Effective Torque Calculations (Example 1)
- 6.7 Effective Torque Calculations (Example 2) for Z Series with High Environmental Resistance

#### 6.1 Loads on the Motor

((1) Load moment of inertia; (2) Axial load, radial load, and moment load; (3) Holding torque required during halts)

##### (1) Load moment of inertia J

When the Megatorque Motor System is used, the size of the moment of inertia of the load mounted to the Motor rotor will significantly affect the acceleration/deceleration characteristics. Thus, calculation of the moment of inertia of the load J is required.

##### (2) Axial load, radial load, and moment load

Calculate the load on the Motor. The relationship between external force and load is represented in the following three patterns. Ensure the axial load/radial load and the moment load are set within the allowable axial, radial and moment loads. (Refer to 2. Motor Specifications in this catalog for allowable loads.)

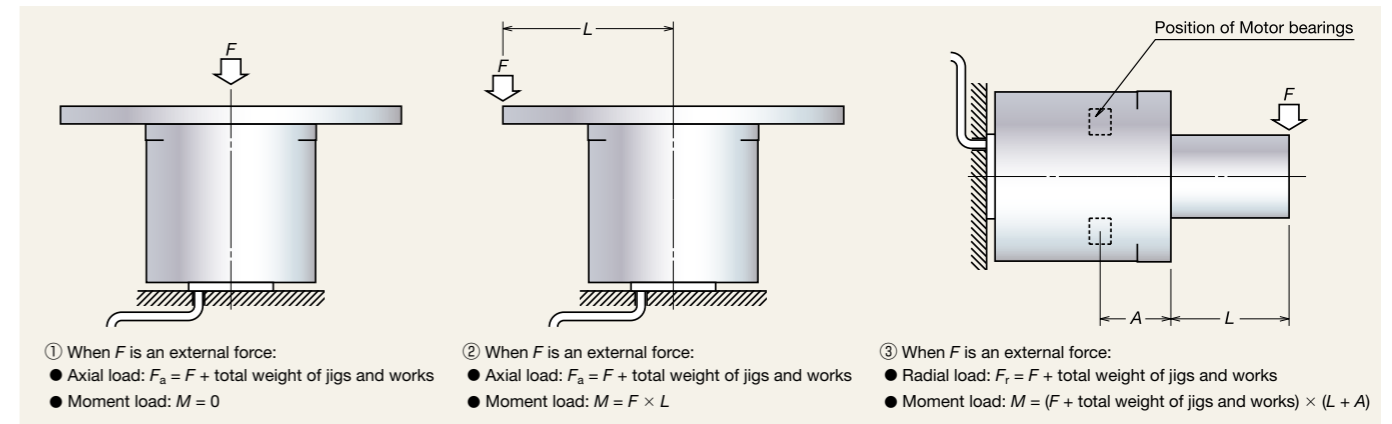

| Motor model      | PS1  | PS3  | PN2  | PN3  | PN4  | PN3 with Brake | PN4 with Brake | PNZ3 | PNZ4 |
|------------------|------|------|------|------|------|----------------|----------------|------|------|
| Dimension A [mm] | 30.2 | 32.9 | 16.7 | 33.8 | 54.2 | 45.8           | 70.2           | 48.8 | 79.2 |

##### (3) Holding torque required during halts

When the arm is halted at the position shown at right, the torque, equal to  $F \times L$ , is applied on the Motor as a load torque. Therefore, limit load torque to equal or below rated torque.

When holding brakes, limit load torque to equal or below brake torque. Contact NSK for positioning accuracy for holding brakes.

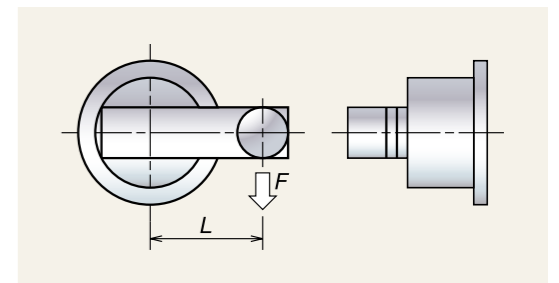

#### 6.2 Runout Accuracy

The measurement method for runout accuracy is shown at right.

#### 6.3 Positioning Accuracy

The positioning accuracy of the Megatorque Motor System is considered by two respects as follows:

- (1) Absolute positioning accuracy: 90 [arc-sec] (interchangeable)
- (2) Repeatability:  $\pm 2$  [arc-sec]

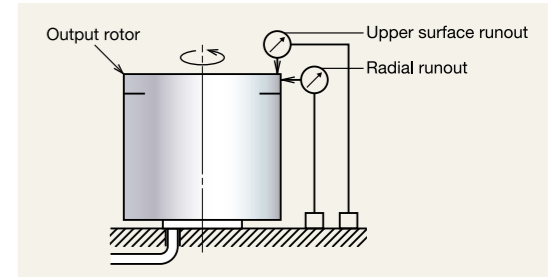



## 6 Selection of Megatorque Motors

### [Example 1]

We examine the compatibility of the PS Series Motors, assuming a required repeatability of  $\pm 0.02$  [mm] at 300 [mm] distance from the center.

From  $\tan \theta = 0.02 \div 300$

$$\begin{aligned}\theta &= \tan^{-1}(0.02 \div 300) \\ &= 3.8 \times 10^{-3} [^\circ] \\ &= 14 [\text{arc-sec}]\end{aligned}$$

Therefore,  $\pm 14 > \pm 2$

Both PS1 and PS3 Models can be used in terms of positioning accuracy.

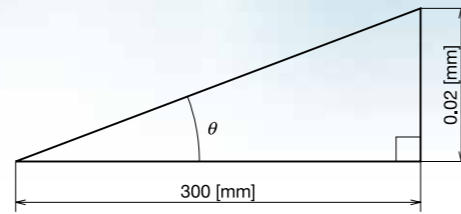

### 6.4 Positioning Time (Index Time)

When a Megatorque Motor is used to index an angle, index times can be roughly calculated as follows.

|   |                      |
|---|----------------------|
| $J_m$ : Load moment of inertia                  | [kg·m <sup>2</sup> ] |
| $J_r$ : Rotor moment of inertia                 | [kg·m <sup>2</sup> ] |
| $N$ : Rotational speed of the Motor             | [s <sup>-1</sup> ]   |
| $T$ : Output torque at the rotational speed $N$ | [N·m]                |
| $T_m$ : Load torque                             | [N·m]                |
| $t_1$ : Travel time                             | [s]                  |
| $t_2$ : Settling time                           | [s]                  |
| $t_3$ : Positioning time                        | [s]                  |
| $\Delta t$ : Accelerating/decelerating time     | [s]                  |
| $\theta$ : Rotational angle                     | [°]                  |
| $\eta$ : Safety coefficient (normally 1.4-1.5)  |                      |

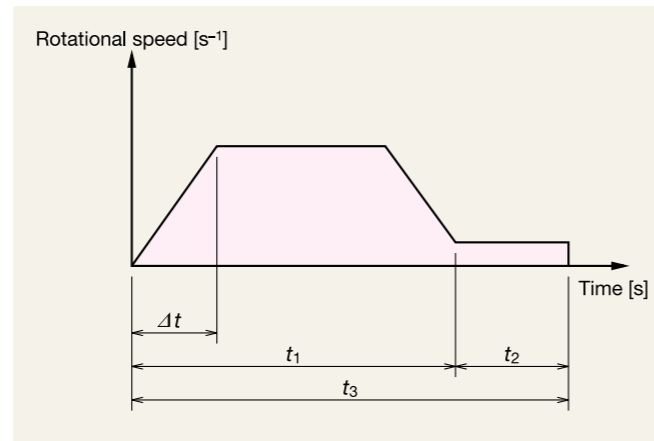

Please refer to the following table for the settling time. Since the settling time will also be affected by factors such as the magnitude of the moment of inertia of the load and rigidity of the whole structure, the settling time is not absolute.

| Required repeatability [arc-sec] | Settling time $t_2$ [s] |
|----------------------------------|-------------------------|
| $\pm 2$ to $\pm 10$              | 0.1                     |
| $\pm 10$ to $\pm 100$            | 0.04                    |
| $\pm 100$ and above              | 0.001                   |

In accordance with the list above,

$$\Delta t = \frac{(J_m + J_r) \times 2\pi N}{(T - T_m)} \times \eta$$

$$t_1 = \frac{\theta}{360 \times N} + \Delta t$$

$$t_3 = t_1 + t_2$$

Where  $T - T_m > 0$ , and  $2 \times \Delta t \leq t_1$

### 6.5 Selection of Optional Regeneration Resistor

#### (1) Obtain rotational energy of Megatorque Motor during deceleration

Calculate the rotational energy using the following equation:

$$\begin{aligned}\text{Rotational energy} &= 1/2 \times J \times \omega^2 [\text{J}] & J_r &: \text{Rotor inertia [kg·m}^2\text{]} \\ &= 1/2 \times J \times (2\pi N)^2 [\text{J}] & J_m &: \text{Moment of inertia of the load [kg·m}^2\text{]} \\ J &= J_r + J_m & N &: \text{Rotational speed [s}^{-1}\text{]}\end{aligned}$$

#### (2) Regenerative energy capacity by internal capacitors

The regeneration energy that can be charged by the internal capacitors is 28 [J].

#### (3) Calculate energy consumed by optional regeneration resistor

Energy consumed by optional regeneration resistor [J] = Rotational energy [J] - 28 [J] (capacitor absorption energy)

When the difference is zero or less, no optional regeneration resistor is necessary.

When the difference is greater than zero, use the following procedure to obtain the required capacity for an optional regeneration resistor.

#### (4) Calculate required capacity for optional regeneration resistor

Required capacity for an optional regeneration resistor [W] = Energy consumed by optional regeneration resistor [J] / (Operation cycle [s] × 0.25)

0.25: Load ratio of optional regeneration resistor use

When the quotient is 7 or less, use optional regeneration resistor: M-E014DCKR1-100. (optional)

When the quotient is 120 or less, use optional regeneration resistor: M-E014DCKR1-101. (optional)

Please contact NSK when the quotient exceeds 120.

### 6.6 Effective Torque Calculations (Example 1)

When selecting a Megatorque Motor, it is necessary to consider the maximum required torque and the effective torque required for the actual operation.

Determine whether 90 [°] can be positioned in 0.24 [s], assuming the load moment of inertia is 0.05 [kg·m<sup>2</sup>]. Also calculate the effective torque when an operation cycle is 0.3 [s].

Conditions: Maximum rotational speed = 2.5 [s<sup>-1</sup>]

Rotational acceleration = 25 [s<sup>-2</sup>]

Repeatability =  $\pm 15$  [arc-sec]

Dwell time = 0.06 [s]

$J_m$  (load moment of inertia) = 0.05 [kg·m<sup>2</sup>]

$J_r$  (rotor moment of inertia) = 0.019 [kg·m<sup>2</sup>] (for PS3060)

- Since the rotational acceleration is 25 [s<sup>-2</sup>], calculate the approximate required torque using the following equation.

$$\begin{aligned}\text{Equations: } T &: \text{Torque at accelerating [N·m]} & \alpha &: \text{Rotational acceleration [s}^{-2}\text{]} = 25 [\text{s}^{-2}] \\ J_m &: \text{(Load moment of inertia [kg·m}^2\text{])} = 0.05 [\text{kg·m}^2] & \eta &: \text{Safety coefficient} = 1.4 \\ J_r &: \text{(Rotor moment of inertia [kg·m}^2\text{])} = 0.019 [\text{kg·m}^2]\end{aligned}$$

Required torque at accelerating/decelerating

$$T = (J_m + J_r) \times \alpha = (0.05 + 0.019) \times 2\pi \times 25 = 10.8 [\text{N·m}]$$

Therefore, the candidate selection is a motor with a maximum output torque of 15.2 [N·m] (obtained by multiplying required torque by a safety factor of 1.4) or larger. The PS1 Model (excluding PS1006 and PS1012), PS3 Model, PN3 Model, or PN4 Model can be selected.

Note: Since the moment of inertia of the rotor of the motor varies depending on the motor, the required torque needs to be recalculated for each motor.

- The effective torque required for the actual operational pattern in use (see following diagram) needs to be examined.

Also determine whether the PS3060 meets the operational conditions.

$\Delta t$ : accelerating/decelerating time = 0.1 [s],  $t_2$ : settling time = 0.04 [s],

$t_3$ : dwell time = 0.06 [s],  $t_4$ : cycle time =  $2 \times \Delta t + t_2 + t_3 = 0.3$  [s]

$$\text{Required effective torque} = \sqrt{\frac{T^2 \times \Delta t \times 2}{t_4}} = 8.8 [\text{N·m}]$$

$$\text{Rotational energy} = 1/2 \times (J_m + J_r) \times (2\pi N)^2 = 1/2 \times (0.05 + 0.019) \times (2\pi \times 2.5)^2 = 8.5 [\text{J}]$$

An effective torque of 11.4 [N·m] is determined by multiplying the equation above by a temperature coefficient of 1.3, which is less than the PS3060's rated output torque of 20 [N·m]. Therefore, the PS3060 sufficiently meets the operational conditions and no optional regeneration resistor is necessary.

- In case results do not meet rated torque  $\geq$  effective torque, recalculation with revised conditions is required.

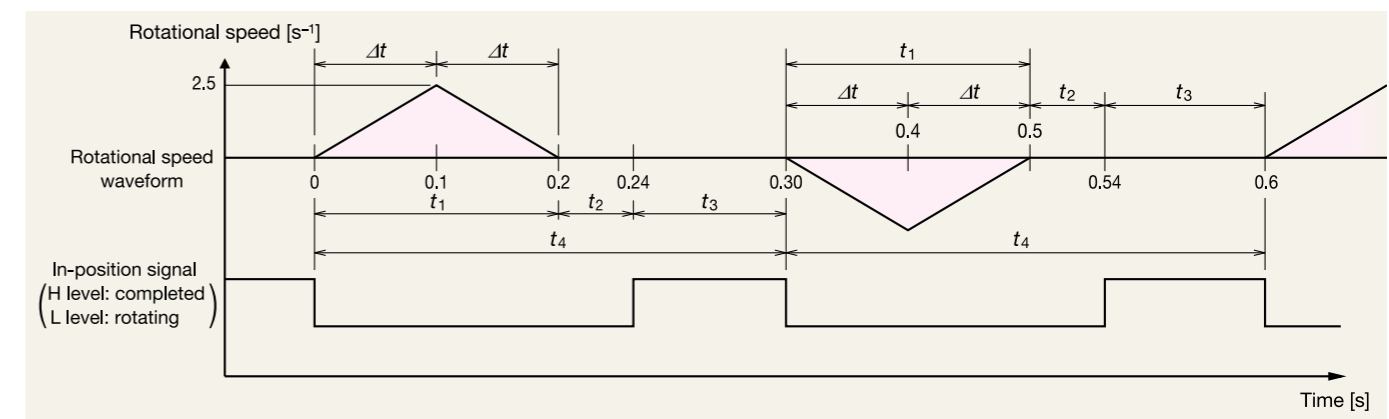

## 6 Selection of Megatorque Motors

### 6.7 Effective Torque Calculations (Example 2) for Z Series with High Environmental Resistance

When selecting a Megatorque Motor, it is necessary to consider the maximum required torque and the allowable effective torque required for the actual operation.

Determine whether 90 [°] can be positioned in 0.24 [s], assuming the load moment of inertia is 0.05 [kg·m<sup>2</sup>]. Also calculate the effective torque when an operation cycle is 0.3 [s].

Conditions: Maximum rotational speed = 2.5 [s<sup>-1</sup>]  
 Rotational acceleration = 25 [s<sup>-2</sup>]  
 Repeatability = ±15 [arc-sec]  
 Dwell time = 0.06 [s]  
 $J_m$  (load moment of inertia) = 0.05 [kg·m<sup>2</sup>]  
 $J_r$  (moment of inertia of the rotor) = 0.12 [kg·m<sup>2</sup>] (for PNZ4130)  
 $T_i$  = Internal load torque = 15 [N·m]

- Since the rotational acceleration is 25 [s<sup>-2</sup>], calculate the approximate required torque using the following equations.

Equations:  $T$ : Torque at accelerating [N·m]  
 $\alpha$ : Rotational acceleration [s<sup>-2</sup>] = 25 [s<sup>-2</sup>]  
 $J_m$ : (Load moment of inertia) = 0.05 [kg·m<sup>2</sup>]  
 $\eta$ : Safety coefficient = 1.4  
 $J_r$ : (Rotor moment of inertia) = 0.12 [kg·m<sup>2</sup>]

Required torque at accelerating/decelerating  
 $T = (J_m + J_r) \times \alpha = (0.05 + 0.12) \times 2\pi \times 25 = 26.7$  [N·m]

|                | Allowable effective torque [N·m] | Internal load torque [N·m] |
|----------------|----------------------------------|----------------------------|
| M-PNZ3040KN001 | 15                               | 10                         |
| M-PNZ4130KN001 | 45                               | 15                         |
| M-PNZ4175KN001 | 60                               | 15                         |

Therefore, the candidate selection is a motor with a maximum output torque of 37.4 [N·m] (obtained by multiplying required torque by a safety factor of 1.4) or larger. The PNZ3 Model or PNZ4 Model can be selected.

Note: Since the moment of inertia of the rotor of the motor varies depending on the motor, the required torque needs to be recalculated for each motor.

- The effective torque required for the actual operational pattern in use (see following diagram) needs to be examined.

Also determine whether the PNZ4130 meets the operational conditions.

$\Delta t$  = accelerating/decelerating time = 0.1 [s],  $t_2$ : settling time = 0.04 [s],  $t_3$ : dwell time = 0.06 [s],

$t_5$ : constant speed time = 0 [s],  $t_4$ : cycle time =  $2 \times \Delta t + t_2 + t_3 + t_5 = 0.3$  [s]

$$\text{Effective torque} = \sqrt{\frac{(T+T_i)^2 \times \Delta t + (T-T_i)^2 \times \Delta t + T_i^2 \times t_5}{t_4}} = 25.0 \text{ [N·m]}$$

$$\text{Rotational energy} = 1/2 \times (J_m + J_r) \times (2\pi N)^2 = 1/2 \times (0.05 + 0.12) \times (2\pi \times 2.5)^2 = 21.0 \text{ [J]}$$

An effective torque of 32.5 [N·m] is determined by multiplying the equation above by a temperature coefficient of 1.3, which is less than the PNZ4130's allowable effective torque of 45 [N·m]. Therefore, the PNZ4130 sufficiently meets the operational conditions and no optional regeneration resistor is necessary.

- In case results do not meet allowable effective torque  $\geq$  effective torque, recalculation with revised conditions is required.

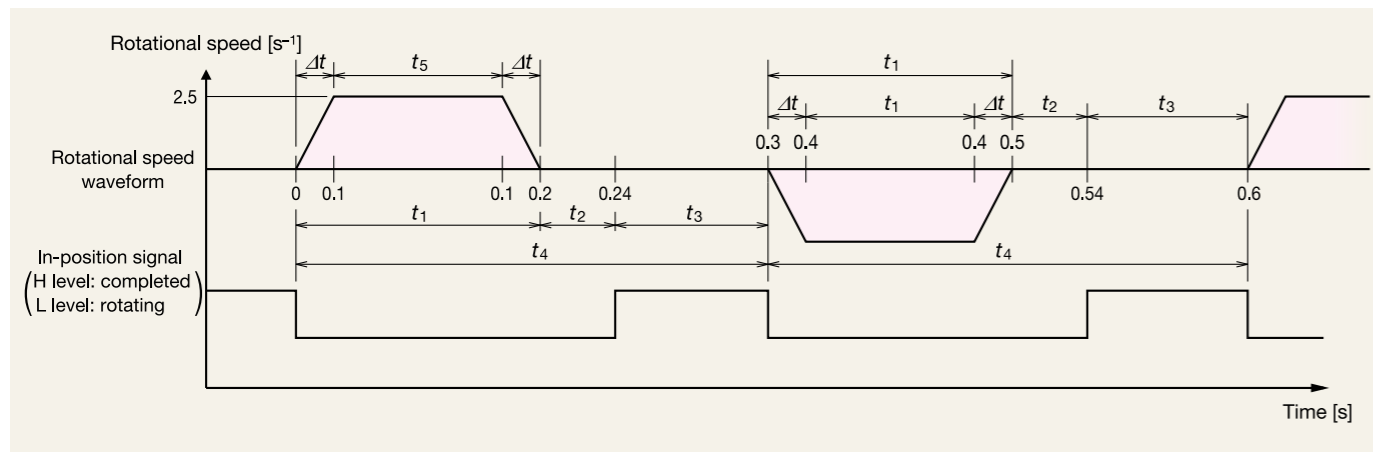

## 7 Positioning Time Diagrams

The positioning time for Megatorque Motors is calculated in accordance with "6.3 Positioning time." When dwell time is relatively longer than accelerating/decelerating time (dwell time > accelerating/decelerating time x 10), rough positioning time can be determined using the following positioning time diagrams.

These diagrams only apply under the following conditions.

- The motor is directly connected to the load (without gear reducer, belt, or couplings), and the rigidity of the load is sufficiently high (natural frequency: More than 100 [Hz]).

- No load torque is applied to the motor.

The following conditions require additional considerations.

#### a. When the load's moment of inertia exceeds the allowable moment load and is off the diagram:

Operation is possible, although much more time may be required than shown in the diagram, since rotational speed and acceleration are limited.

#### b. When there is no diagram for the relevant positioning angle:

An appropriate calculation is required. No calculation, however, is effective for very small angles.

Settling time of 0.001 [s] has been included. Add more settling time when higher repeatability is required.

Example: Motor: PN4180  
 Moment of inertia: 3.0 [kg·m<sup>2</sup>]  
 Index angle: 45 [°]

| Required repeatability [arc-sec] | Settling time [s] |
|----------------------------------|-------------------|
| ±2 to ±10                        | 0.1               |
| ±10 to ±100                      | 0.04              |
| ±100 and above                   | 0.001             |

Minimum positioning time of 0.3 [s] is determined according to the line in the following diagram.

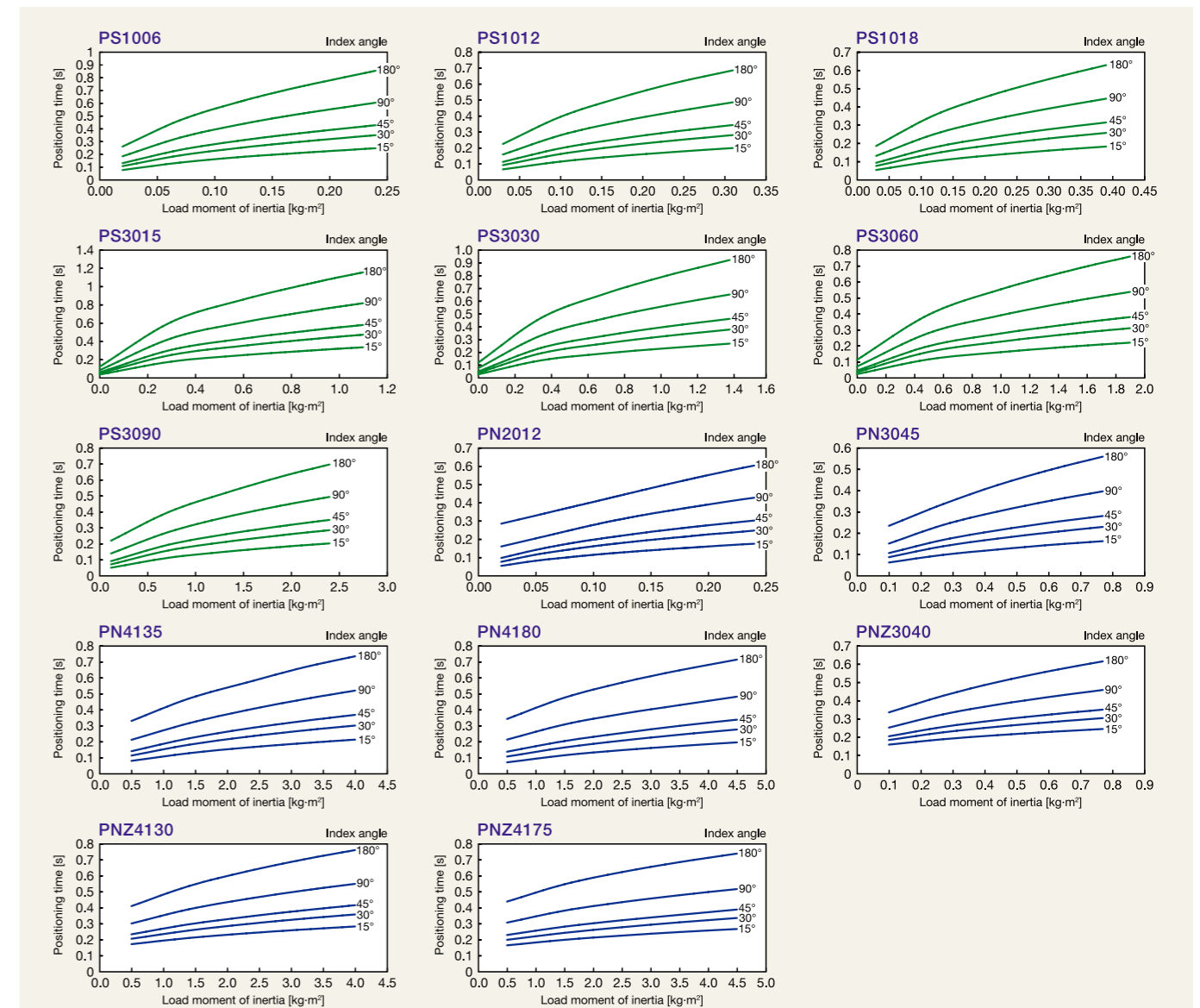

# 8 Installation

## 8.1 Installation of Motor

- Install and secure the Motor on a rigid base, otherwise mechanical vibrations may occur.
- Mount the motor using the tapped or through-holes.
- The mounting surface flatness should be less than 0.02 [mm].
- The Motor can be attached either horizontally or vertically. (For Z Series with High Environmental Resistance, do not install in the upside-down position.)
- Take care not to push up the underside cover when attaching the motor. (PS Series)
- Please see below figure for counterbore depth from base top. (PS Series)
- The bend radius of the motor cable lead and the resolver cable lead should be R30 [mm] or more. Do not use the leads of the motor cable and the resolver cable with flexing motion.

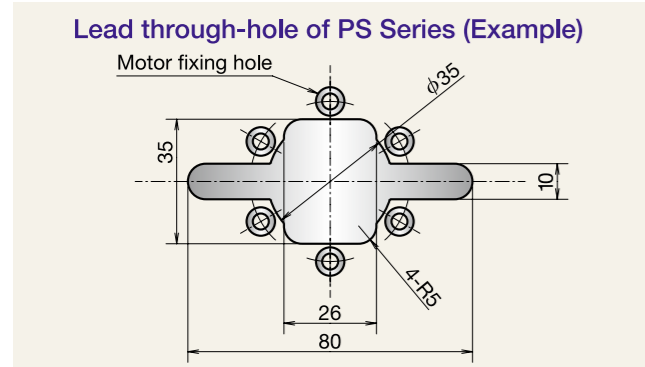
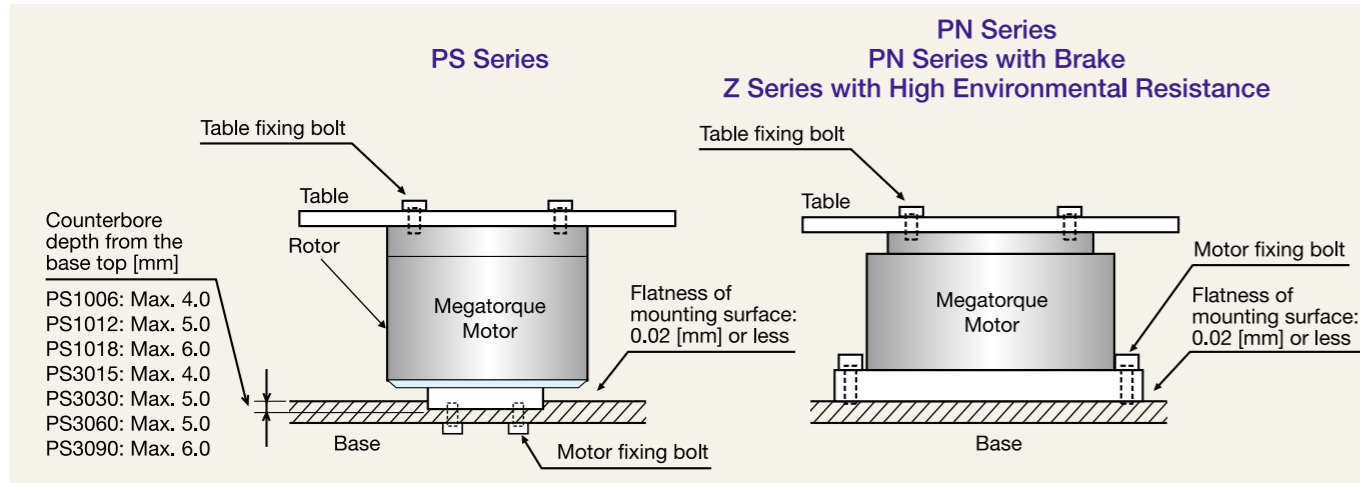

When inserting the PS Series connector through the bottom of the base, making a larger hole than is shown in this figure is recommended.

Note: If the motor is installed as indicated in the figure below, mechanical vibrations will be generated and the velocity loop proportional gain (VG) cannot be increased. It will occur overshoot and the motor can not operate smoothly.

- Attach the load directly to the motor rotor.
- Mount the motor directly to the base.

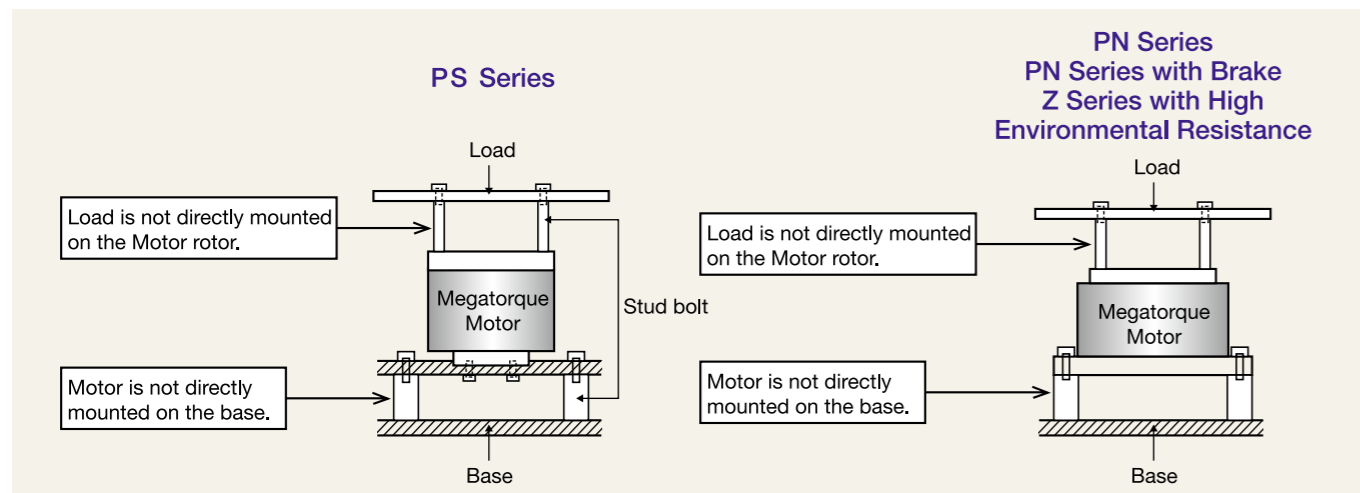

## 8.2 Dummy Inertia

For the full use of the benefits of the direct drive motor system, it is essential to maximize the resonance frequency of the whole mechanism by increasing the rigidity of the load, as well as securely fastening the Motor to a highly rigid mechanical system. Therefore, adding some dummy load to the rotor directly may help in the following cases.

- A key is used to fix the load to the rotor because the load cannot be directly attached to the rotor.
- The load is directly fixed to the rotor. However, vibration occurs due to torsional deflection on the rotary axis of the load.
- Inertia of the whole mechanism is very low when a thin shaft such as a ball screw shaft is attached.
- There exists play because a sprocket chain or a gear train is used.
- Vibration occurs because the rigidity of the structure is low, such as when the Motor is being used for driving a belt.

- Inertia of a dummy load shall be approximately 20% of the load inertia. When a speed reducer mechanism is used, it shall be
 
$$GD^2_1 / (r^2 \times GD^2_d) \leq 5$$
 Where  $GD^2_1$  = inertia of indirectly connected load,  $GD^2_d$  = inertia of directly attached load, and  $r$  = reduction ratio.

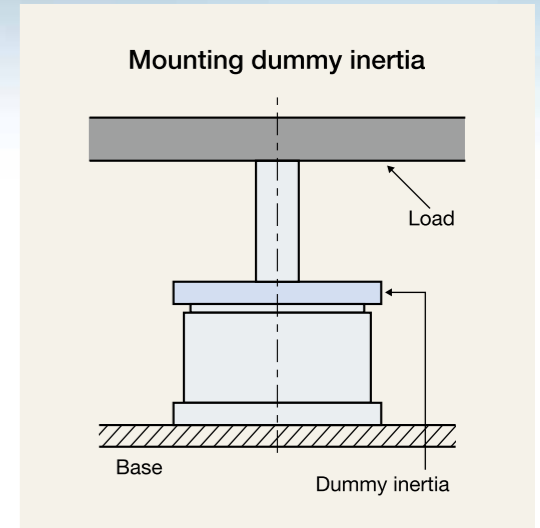

## 8.3 Installation of Driver Unit

- The EDC Driver Unit must be fixed so that fins are in the vertical position for natural air-cooling.
- Ambient temperatures should be in a range from 0 to 50 [°C]. The Driver Unit cannot be used in excess of 50 [°C]. A sufficient space of at least 100 [mm] should be provided both above and below the Driver Unit in a control cabinet. Operate the Driver Unit in an environment in which internally generated heat can be dissipated. If heat is trapped above the Driver Unit, open the space above it to allow for the heat to dissipate (in this case, also take steps to prevent the entry of dust) or provide a forced-air cooling system.
- Use the Driver Unit in a control cabinet with IP54 or higher. Protect the Driver Unit from exposure to oil mist, cutting water, cutting dust, coating gas, etc., to prevent their entry into the Driver Unit through ventilation openings, which may cause circuit failure.
- When installing two or more Driver Units for multi-axis combinations, provide a 10 [mm] or more space between adjacent Driver Units.
- The Driver Unit can be attached to a panel using front mounting brackets (optional).
- The maximum power loss of the EDC Driver Unit is 55 [W].

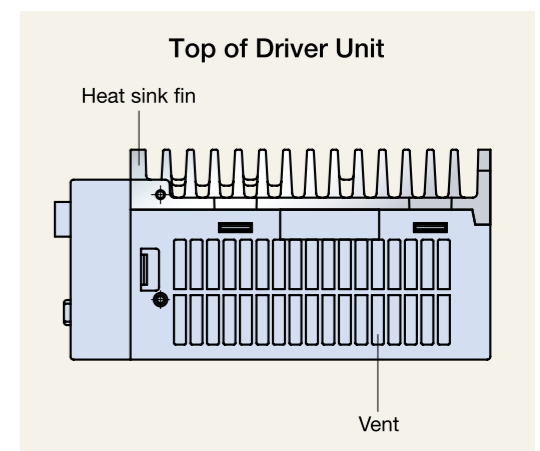
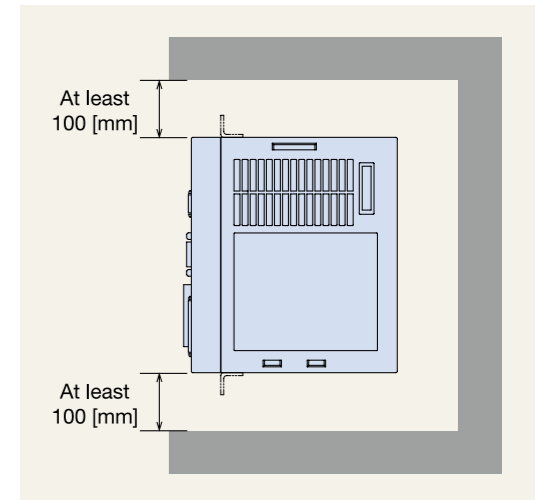

# 9 Motor and EDC Driver Unit Combinations

## 9.1 PS Series and EDC Driver Unit Combinations

| Motor Outer Diameter | Reference Number Coding of Motor | EDC Driver Unit Reference Number (** indicates accessories specification) | Power Voltage [VAC] | Cable Reference Number  | Main Specifications                                      |
|----------------------|----------------------------------|---|---------------------|---|--|
| ∅ 100                | M-PS1006KN002                    | M-EDC-PS1006AB502-**  | 200 to 230          | M-C*** SCP03 (Stationary cable)<br>M-C*** SCP13 (Flexible cable)<br>*** indicates cable length.<br><br>001: 1 [m]<br>002: 2 [m]<br>003: 3 [m]<br>004: 4 [m]<br>005: 5 [m]<br>006: 6 [m]<br>008: 8 [m]<br>010: 10 [m]<br>015: 15 [m]<br>020: 20 [m]<br>030: 30 [m] | 256 program channels<br>Pulse train input (Photocoupler) |
|                      |                                  | M-EDC-PS1006CB502-**  | 100 to 115          |   |  |
|                      | M-PS1012KN002                    | M-EDC-PS1012AB502-**  | 200 to 230          |   |  |
|                      |                                  | M-EDC-PS1012CB502-**  | 100 to 115          |   |  |
|                      | M-PS1018KN002                    | M-EDC-PS1018AB502-**  | 200 to 230          |   |  |
|                      |                                  | M-EDC-PS1018CB502-**  | 100 to 115          |   |  |
| ∅ 150                | M-PS3015KN002                    | M-EDC-PS3015AB502-**  | 200 to 230          |   |  |
|                      |                                  | M-EDC-PS3015CB502-**  | 100 to 115          |   |  |
|                      | M-PS3030KN002                    | M-EDC-PS3030AB502-**  | 200 to 230          |   |  |
|                      |                                  | M-EDC-PS3030CB502-**  | 100 to 115          |   |  |
|                      | M-PS3060KN002                    | M-EDC-PS3060AB502-**  | 200 to 230          |   |  |
|                      |                                  | M-EDC-PS3060CB502-**  | 100 to 115          |   |  |
| M-PS3090KN002        | M-EDC-PS3090AB502-**             | 200 to 230  |                     |   |  |
|                      | M-EDC-PS3090CB502-**             | 100 to 115  |                     |   |  |
| ∅ 100                | M-PS1006KN002                    | M-EDC-PS1006ABC02-**  | 200 to 230          | CC-Link function<br>256 program channels  |  |
|                      |                                  | M-EDC-PS1006CBC02-**  | 100 to 115          |   |  |
|                      | M-PS1012KN002                    | M-EDC-PS1012ABC02-**  | 200 to 230          |   |  |
|                      |                                  | M-EDC-PS1012CBC02-**  | 100 to 115          |   |  |
|                      | M-PS1018KN002                    | M-EDC-PS1018ABC02-**  | 200 to 230          |   |  |
|                      |                                  | M-EDC-PS1018CBC02-**  | 100 to 115          |   |  |
| ∅ 150                | M-PS3015KN002                    | M-EDC-PS3015ABC02-**  | 200 to 230          |   |  |
|                      |                                  | M-EDC-PS3015CBC02-**  | 100 to 115          |   |  |
|                      | M-PS3030KN002                    | M-EDC-PS3030ABC02-**  | 200 to 230          |   |  |
|                      |                                  | M-EDC-PS3030CBC02-**  | 100 to 115          |   |  |
|                      | M-PS3060KN002                    | M-EDC-PS3060ABC02-**  | 200 to 230          |   |  |
|                      |                                  | M-EDC-PS3060CBC02-**  | 100 to 115          |   |  |
| M-PS3090KN002        | M-EDC-PS3090ABC02-**             | 200 to 230  |                     |   |  |
|                      | M-EDC-PS3090CBC02-**             | 100 to 115  |                     |   |  |

## 9.2 PN Series and EDC Driver Unit Combinations

| Motor Outer Diameter | Reference Number Coding of Motor | EDC Driver Unit Reference Number (** indicates accessories specification) | Power Voltage [VAC] | Cable Reference Number   | Main Specifications                                      |
|----------------------|----------------------------------|---|---------------------|--|--|
| ∅ 170                | M-PN2012KN201                    | M-EDC-PN2012AB502-**  | 200 to 230          | Refer to 9.1.<br><br>(Maximum cable length for PN2012 is 8 [m].) | 256 program channels<br>Pulse train input (Photocoupler) |
|                      |                                  | M-EDC-PN2012CB502-**  | 100 to 115          |  |  |
| ∅ 210                | M-PN3045KN001                    | M-EDC-PN3045AB502-**  | 200 to 230          |  |  |
|                      |                                  | M-EDC-PN3045CB502-**  | 100 to 115          |  |  |
| ∅ 280                | M-PN4135KN001                    | M-EDC-PN4135AB502-**  | 200 to 230          |  |  |
|                      |                                  | M-EDC-PN4180KN001   | 200 to 230          |  |  |
| ∅ 170                | M-PN2012KN201                    | M-EDC-PN2012ABC02-**  | 200 to 230          |  | CC-Link function<br>256 program channels                 |
|                      |                                  | M-EDC-PN2012CBC02-**  | 100 to 115          |  |  |
| ∅ 210                | M-PN3045KN001                    | M-EDC-PN3045ABC02-**  | 200 to 230          |  |  |
|                      |                                  | M-EDC-PN3045CBC02-**  | 100 to 115          |  |  |
| ∅ 280                | M-PN4135KN001                    | M-EDC-PN4135ABC02-**  | 200 to 230          |  |  |
|                      |                                  | M-EDC-PN4180KN001   | 200 to 230          |  |  |

## 9.3 PN Series with Brake and EDC Driver Unit Combinations

| Motor Outer Diameter | Reference Number Coding of Motor | EDC Driver Unit Reference Number (** indicates accessories specification) | Power Voltage [VAC] | Cable Reference Number | Main Specifications                                      |
|----------------------|----------------------------------|---|---------------------|------------------------|--|
| ∅ 210                | M-PN3045KG001                    | M-EDC-PN3045AB502-**  | 200 to 230          | Refer to 9.1.          | 256 program channels<br>Pulse train input (Photocoupler) |
|                      |                                  | M-EDC-PN3045CB502-**  | 100 to 115          |                        |  |
| ∅ 280                | M-PN4135KG001                    | M-EDC-PN4135AB502-**  | 200 to 230          |                        |  |
| ∅ 210                | M-PN3045KG001                    | M-EDC-PN3045ABC02-**  | 200 to 230          |                        |  |
|                      |                                  | M-EDC-PN3045CBC02-**  | 100 to 115          |                        |  |
| ∅ 220                | M-PN4135KG001                    | M-EDC-PN4135ABC02-**  | 200 to 230          |                        | CC-Link function<br>256 program channels                 |

## 9.4 Z Series with High Environmental Resistance and EDC Driver Unit Combinations

| Motor Outer Diameter | Reference Number Coding of Motor | EDC Driver Unit Reference Number (** indicates accessories specification) | Power Voltage [VAC]  | Cable Reference Number   | Main Specifications                                      |
|----------------------|----------------------------------|---|----------------------|--|--|
| ∅ 220                | M-PNZ3040KN001                   | M-EDC-PN3045AB502-**  | 200 to 230           | M-C*** WCP13 (Flexible cable, straight connector)<br>M-C*** WCP14 (Flexible cable, angle connector)<br>*** indicates cable length.<br>002: 2 [m]<br>004: 4 [m]<br>006: 6 [m]<br>008: 8 [m]<br>010: 10 [m]<br>015: 15 [m]<br>020: 20 [m]<br>030: 30 [m] | 256 program channels<br>Pulse train input (Photocoupler) |
|                      |                                  | M-EDC-PN3045CB502-**  | 100 to 115           |  |  |
| ∅ 286                | M-PNZ4130KN001                   | M-EDC-PN4135AB502-**  | 200 to 230           |  |  |
|                      |                                  | M-PNZ4175KN001  | M-EDC-PN4180AB502-** |  |  |
| ∅ 220                | M-PNZ3040KN001                   | M-EDC-PN3045ABC02-**  | 200 to 230           |  | CC-Link function<br>256 program channels                 |
|                      |                                  | M-EDC-PN3045CBC02-**  | 100 to 115           |  |  |
| ∅ 286                | M-PNZ4130KN001                   | M-EDC-PN4135ABC02-**  | 200 to 230           |  |  |
|                      |                                  | ∅ 286   | M-PNZ4175KN001       |  |  |

## 9.5 Options

| Item                        | Reference number               | Contents  |
|-----------------------------|--------------------------------|---|
| Connector                   | M-E014DCFS1-001                | CN2 connector (user side) for standard function   |
|                             | M-E014DCFS1-006                | CN2 connector (user side) for CC-Link function  |
|                             | M-E014DCFS1-002                | CN5 connector (user side)   |
|                             | M-E014DCFS1-003                | CN6 connector (user side)   |
| Mounting bracket            | M-E050DCKA1-001                | Driver Unit mounting brackets   |
|                             | M-E099DC0C2-155                | User's Manual (Japanese version)  |
| Manual                      | M-E099DC0C2-158                | User's Manual (English version)   |
|                             | M-E099DC0C2-156                | CC-Link option instruction manual (Japanese version)  |
|                             | M-E099DC0C2-157                | CC-Link option instruction manual (English version)   |
|                             | Optional regeneration resistor | M-E014DCKR1-100   |
| M-E014DCKR1-101             |                                | Optional regeneration resistor (120[W])   |
| Accessory set               | M-E014DCFS1-004                | Set of M-E014DCFS1-001, M-E014DCFS1-002, and M-E050DCKA1-001  |
| RS-232C Communication Cable | M-C003RS03                     | Communication cable between PC and EDC driver unit (Cable length: 3 [m])                              |
| Cable with CN2 connector    | M-E011DCCN1-001                | Cable with CN2 connector for CC-Link function (Cable length: 3 [m])                                   |
| Handy Terminal              | M-FHT21                        | RS-232C interface terminal for inputting parameter/program into EDC driver unit (Cable length: 3 [m]) |

# 10 “EDC Megaterm” Application Software

Once installed on your computer, this software enables the editing, preparation and control of EDC Driver Unit programs and parameters. It also facilitates the allocation and monitoring of control input/output. And its oscilloscope function allows for easy confirmation of Motor operation.

EDC Megaterm can be downloaded for free from the NSK Web site (<http://www.nsk.com/>).

RS-232C communication cable is available (option).

Type: M-C003RS03 (cable length: 3 [m])

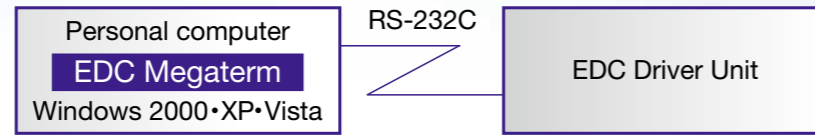

- A USB port can be used on a PC without a COM port. In this case, use a commercial RS-232C/USB conversion adaptor for communication. We have confirmed the compatibility of the SRC06-USB, USB serial cable made by Arvel.
- The RS-232C communication connector for the EDC Driver Unit has a different pin configuration than that for a PC.

## Functions

1. Oscilloscope function
2. Allocation and monitoring of control input/output
3. Parameter editing
4. Channel editing
5. Others:
  - Upload/download parameter and channel data
  - Terminal



## Main Functions

### 1. Oscilloscope function

- 4-channel oscilloscope, 10 [k sampling/s] maximum
- Anything that can be monitored using the handy terminal can be displayed on the oscilloscope.
- Monitor scales are adjustable.
- Measured waveforms are output as bitmaps or CSV format.

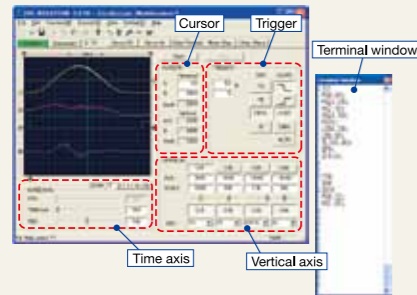

### 2. Allocation and monitoring of control input/output

- Allocation of control input/output by drag-and-drop editing
- Monitoring of input/output signals
- Report of allocation list

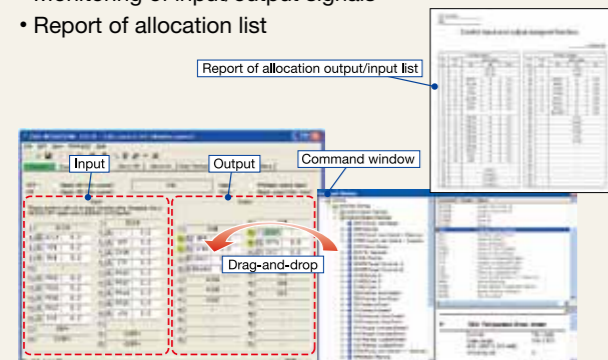

### 3. Parameter edits

- Parameter edits take effect in real time (off-line editing is also supported)
- Parameter-by-parameter reset to default
- Help function for parameters
- Report of parameter setting list

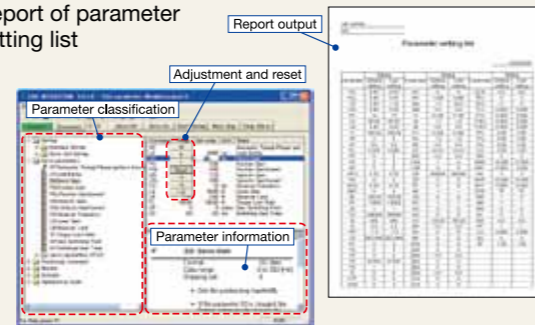

### 4. Channel edits

- Drag-and-drop edits from command window
- Direct input capability also supported (automatic insertion of comments)
- Report of program list

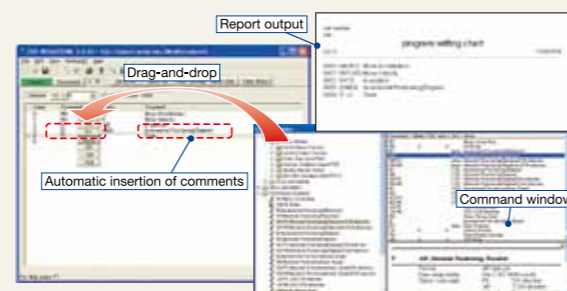

# 11 International Safety Standards and Warranty Information

## CE Marking (PS/PN Series only)

### • Low voltage command (applicable standard: EN50178)

The Megatorque Motor PS/PN Series is incorporated into machinery as components. NSK set low voltage standards to ensure the Megatorque Motor PS Series fully complies with the EC Directive. The standards have been certified by TÜV, a third-party testing and certification organization.

### • EMC command (applicable standards: EMI EN55011 and EMS EN61000-6-2)

NSK defined installation models (conditions) for the Megatorque Motor PS/PN Series, including installation space and wiring between Driver Units and Motors, and set EMC command standards based on 4 [m] cable models, which have been certified by TÜV.

When Megatorque Motor PS/PN Series is incorporated into machinery, real-world installation and/or wiring conditions may differ from those of established models. Therefore, it is necessary to check for EMC command compliance (especially radiation and conduction noise) in the machinery incorporating the PS/PN Series Motors.

## Compliance with UL Standards (PS/PN Series only)

### • Motor

UL Recognized Component  
Compliant with UL1004-1 (File No.: E216970)

### • Driver Unit

Compliant with UL508C (File No.: E216221)

### • Cable set

UL-compliant cables are used

## Warranty Period

- The warranty period is either one year from delivery or 2 400 hours of operation, whichever comes first.

## Limited Warranty

- The warranty is limited to the products supplied by NSK Ltd.
- The defective products will be repaired free of charge within the applicable warranty period.
- Repairs after the expiration of the applicable warranty period will be subject to payment.

## Immunities

- The product is not warranted in one of the following cases even within the warranty period.
  - Failure of the unit due to installation and operation not in accordance with the instruction manual specified by the supplier.
  - Failure of the unit due to improper handling and use, modification and careless handling by the user.
  - Failure of the unit due to the causes other than those attributable to the supplier.
  - Failure of the unit due to modification or repair that is conducted by a person(s) or party (ies) other than the supplier.
  - Other types of failures due to natural disasters and accidents (causes not attributable to the responsibility of the supplier).
- Damages induced by a failure of the supplied unit are not covered.

## Services Fee

- Prices of goods do not include any applicable service charges, such as the dispatching of engineers.
- Startup or maintenance services that require the dispatching of engineers are subject to payment even during the applicable warranty period.
- Service charges will be invoiced in accordance with the supplier's standard service charge list.

## Discontinuation of Production and Maintenance Service Period

- Any discontinuation of production will be announced one year in advance. The maintenance service period is five (5) years after discontinuation of production. Announcement will be released by the supplier or published on the NSK Web site.

## Special-purpose Applications

- This product is intended for general industrial applications and is not designed or manufactured for use under dangerous conditions.
- Contact NSK before using this product for any special-purpose applications, including nuclear power equipment and systems or aerospace, medical, and safety devices.
- While this product is manufactured under strict quality controls, NSK recommends that an appropriate safety device be installed when used with equipment that could cause serious accidents or damage in the event of product failure.

# 12 Form for Requesting Megatorque Motor Selection

NSK will assist in selecting the optimal Megatorque Motor. Please fill in the necessary items on the below form and send it by fax to the local NSK office.

Items marked with **○** represent the important information required for selection. Please provide as much detail as possible.

To be completed by customer

Example of completed form

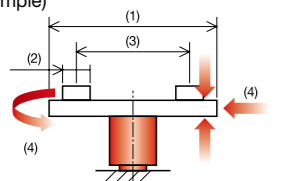
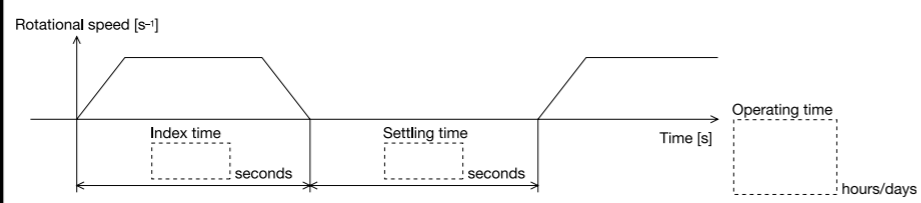
|  |  |
|--|--|
| To _____   | Date (DD/MM/YYYY): / / _____   |
| ○ Company Name: _____  | ○ Section: _____   |
| ○ Name: _____  | ○ Contact: _____<br>TEL _____ FAX _____  |
| ○ Application and equipment used (specify with as much detail as possible)   |  |
| ○ Motor installation position (check in <input type="checkbox"/> )   | <input type="checkbox"/> Upright position<br><input type="checkbox"/> Horizontal position<br><input type="checkbox"/> Upside-down position<br><input type="checkbox"/> Others  |
| ○ Load conditions<br>(1) Geometry, dimensions, thickness, material (or mass) of table<br>(2) Dimensions, mass, quantity of loads/jigs<br>(3) PCD (distance between the jigs/loads) (example of description)<br>(Example)<br> | Schematic drawing (an attached illustration showing outside dimensions is acceptable)<br>• Please provide information on outside dimensions, dimensions from the center, material, etc.<br><br>Attachment: <input type="checkbox"/> Yes <input type="checkbox"/> No  |
| (4) External force (pressure/impact load, sliding friction, etc.)  | _____ N <input type="checkbox"/> None <input type="checkbox"/> Always <input type="checkbox"/> At settling <input type="checkbox"/> During rotating <input type="checkbox"/> Some impact<br><input type="checkbox"/> Rotational direction <input type="checkbox"/> Sliding friction<br>*Specify position, direction, etc. in the schematic drawing.  |
| Motor size requested   |  |
| Positioning command system   | <input type="checkbox"/> Internal program system <input type="checkbox"/> Pulse train input operation <input type="checkbox"/> RS-232C operation <input type="checkbox"/> CC-Link  |
| ○ Index angle / Number of points   | Settle at _____ °, Number of points: _____   |
| ○ Repeatability (±)  | ± _____ seconds (± _____ mm at _____ mm from the motor center)   |
| ○ Cycle pattern (desired positioning time)<br>*Specify settling time.  |    |
| ○ Input power voltage  | <input type="checkbox"/> 100 to 115 [VAC] <input type="checkbox"/> 200 to 230 [VAC] <input type="checkbox"/> Others ( _____ [VAC])   |
| Environmental conditions   | Operating environment <input type="checkbox"/> General environment (equivalent to IP30) <input type="checkbox"/> Oil, water and chemical<br><input type="checkbox"/> Chips and dust <input type="checkbox"/> Clean<br>Operating temperature <input type="checkbox"/> 0°C to 40°C <input type="checkbox"/> Below 0°C <input type="checkbox"/> Above 40°C <input type="checkbox"/> Other ( _____ °C)<br>Contact NSK for details. |
| ○ Cable specification and length   | <input type="checkbox"/> Stationary cable <input type="checkbox"/> Flexible cable Length: _____ m<br>Select "Movable" when cable is repeatedly bent anywhere along the wiring route.   |
| Other request items  |  |

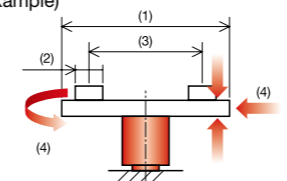
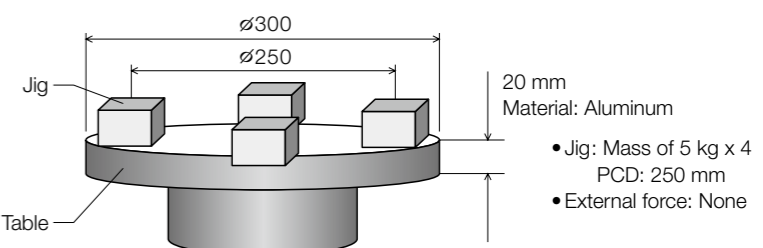
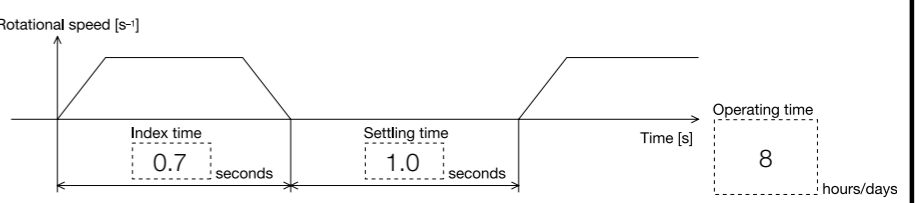
|  |  |
|--|--|
| To Mr. XXX XXX , in charge of Precision Machinery & Parts, NSK   | Date (DD/MM/YYYY): 12 / 01 / 2010  |
| ○ Company Name: YYY Corporation  | ○ Section: Engineering Dept., Engineering Section #1   |
| ○ Name: YYY YYY  | ○ Contact: _____<br>TEL 03-1234-5678 FAX 03-1234-5678  |
| ○ Application and equipment used (specify with as much detail as possible)   | Semiconductor inspection machine   |
| ○ Motor installation position (check in <input type="checkbox"/> )   | <input checked="" type="checkbox"/> Upright position<br><input type="checkbox"/> Horizontal position<br><input type="checkbox"/> Upside-down position<br><input type="checkbox"/> Others   |
| ○ Load conditions<br>(1) Geometry, dimensions, thickness, material (or mass) of table<br>(2) Dimensions, mass, quantity of loads/jigs<br>(3) PCD (distance between the jigs/loads) (example of description)<br>(Example)<br> | Schematic drawing (an attached illustration showing outside dimensions is acceptable)<br>• Please provide information on outside dimensions, dimensions from the center, material, etc.<br><br>  |
| (4) External force (pressure/impact load, sliding friction, etc.)  | 10 N <input type="checkbox"/> None <input type="checkbox"/> Always <input checked="" type="checkbox"/> At settling <input type="checkbox"/> During rotating <input type="checkbox"/> Some impact<br><input type="checkbox"/> Rotational direction <input type="checkbox"/> Sliding friction<br>Force is applied downward to a single point at 125 mm in radius from the center.<br>*Specify position, direction, etc. in the schematic drawing.      |
| Motor size requested   | M-PS3060   |
| Positioning command system   | <input checked="" type="checkbox"/> Internal program system <input type="checkbox"/> Pulse train input operation <input type="checkbox"/> RS-232C operation <input type="checkbox"/> CC-Link   |
| ○ Index angle / Number of points   | Settle at 90 °, Number of points: 4  |
| ○ Repeatability (±)  | ± 20.6 seconds (± 0.01 mm at 100 mm from the motor center)   |
| ○ Cycle pattern (desired positioning time)<br>*Specify settling time.  |   |
| ○ Input power voltage  | <input type="checkbox"/> 100 to 115 [VAC] <input checked="" type="checkbox"/> 200 to 230 [VAC] <input type="checkbox"/> Others ( _____ [VAC])  |
| Environmental conditions   | Operating environment <input checked="" type="checkbox"/> General environment (equivalent to IP30) <input type="checkbox"/> Oil, water and chemical<br><input type="checkbox"/> Chips and dust <input type="checkbox"/> Clean<br>Operating temperature <input checked="" type="checkbox"/> 0°C to 40°C <input type="checkbox"/> Below 0°C <input type="checkbox"/> Above 40°C <input type="checkbox"/> Other ( _____ °C)<br>Contact NSK for details. |
| ○ Cable specification and length   | <input type="checkbox"/> Stationary cable <input checked="" type="checkbox"/> Flexible cable Length: 4 m<br>Select "Movable" when cable is repeatedly bent anywhere along the wiring route.  |
| Other request items  | Please reply by January 12, 2010. (example)  |



## Worldwide Sales Offices

**NSK LTD.-HEADQUARTERS, TOKYO, JAPAN**  
 INDUSTRIAL MACHINERY BUSINESS DIVISION-HEADQUARTERS tel: 03-3779-7227  
 GLOBAL AFTERMARKET DEPARTMENT tel: 03-3779-7253  
 PRECISION MACHINERY DEPARTMENT tel: 03-3779-7163  
 MECHATRONICS BUSINESS DEPARTMENT tel: 0466-21-3027  
 AUTOMOTIVE BUSINESS DIVISION-HEADQUARTERS tel: 03-3779-7189

**Africa**  
**South Africa:**  
**NSK SOUTH AFRICA (PTY) LTD.**  
 Johannesburg tel: 011-458-3600

**Asia and Oceania**  
**Australia:**  
**NSK AUSTRALIA PTY. LTD.**  
 Melbourne tel: 03-9765-4400

**China:**  
**NSK HONG KONG LTD.**  
 Hong Kong tel: 02739-9933  
 Shenzhen tel: 0755-25904886

**KUNSHAN NSK CO., LTD.**  
 Kunshan tel: 0512-5771-5654

**CHANGSHU NSK NEEDLE BEARING CO., LTD.**  
 Jiangsu tel: 0512-5230-1111

**NSK STEERING SYSTEMS DONGGUAN CO., LTD.**  
 Dongguan tel: 0769-2262-0960

**NSK (CHINA) RESEARCH & DEVELOPMENT CO., LTD.**  
 Jiangsu tel: 0512-5796-3000

**NSK (SHANGHAI) TRADING CO., LTD.**  
 Jiangsu tel: 0512-5796-3000

**NSK (CHINA) INVESTMENT CO., LTD.**  
 Jiangsu tel: 0512-5796-3000

Beijing tel: 010-6590-8161  
 Tian Jin tel: 022-8319-5030  
 Changchun tel: 0431-8898-8682  
 Shenyang tel: 024-2334-2868  
 Dalian tel: 0411-8800-8188  
 Nanjing tel: 025-8472-6671  
 Fuzhou tel: 0591-8380-1030  
 Wuhan tel: 027-8556-9630  
 Qingdao tel: 0532-5568-3877  
 Guangzhou tel: 020-3817-7800  
 Changsha tel: 0731-8571-3100  
 Luoyang tel: 0379-6069-6188  
 Xi'an tel: 029-8765-1896  
 Chongqing tel: 023-6806-5310  
 Chengdu tel: 028-8528-3680

**NSK CHINA SALES CO., LTD.**  
 Jiangsu tel: 0512-5796-3000

**India:**  
**RANE NSK STEERING SYSTEMS LTD.**  
 Chennai tel: 044-474-06017

**NSK INDIA SALES CO. PVT. LTD.**  
 Chennai tel: 044-2847-9600  
 Gurgaon tel: 0124-4104-530  
 Kolkata tel: 033-4001-2062  
 Mumbai tel: 022-2838-7787

**NSK-ABC BEARINGS LTD.**  
 Chennai tel: 044-2714-3000

**Indonesia:**  
**PT. NSK INDONESIA**  
 Jakarta tel: 021-252-3458

**Korea:**  
**NSK KOREA CO., LTD.**  
 Seoul tel: 02-3287-0300  
 Changwon tel: 055-287-6001

**Malaysia:**  
**NSK BEARINGS (MALAYSIA) SDN.BHD.**  
 Shah Alam tel: 03-7803-8859

**New Zealand:**  
**NSK NEW ZEALAND LTD.**  
 Auckland tel: 09-276-4992

**Philippines:**  
**NSK REPRESENTATIVE OFFICE**  
 Manila tel: 02-893-9543

**Singapore:**  
**NSK INTERNATIONAL (SINGAPORE) PTE LTD.**  
 Singapore tel: 6496-8000

**NSK SINGAPORE (PRIVATE) LTD.**  
 Singapore tel: 6496-8000

**Taiwan:**  
**TAIWAN NSK PRECISION CO., LTD.**  
 Taipei tel: 02-2509-3305

**TAIWAN NSK TECHNOLOGY CO., LTD.**  
 Taipei tel: 02-2509-3305

**Thailand:**  
**NSK BEARINGS (THAILAND) CO., LTD.**  
 Bangkok tel: 02320-2555

**SIAM NSK STEERING SYSTEMS CO., LTD.**  
 Chachoengsao tel: 038-522-343

**NSK ASIA PACIFIC TECHNOLOGY CENTER (THAILAND) CO., LTD.**  
 Chonburi tel: 038-454-631

**Vietnam:**  
**NSK VIETNAM CO., LTD.**  
 Hanoi tel: 04-3955-0159

**NSK REPRESENTATIVE OFFICE**  
 Ho Chi Minh City tel: 08-3822-7907

**Europe**  
**NSK EUROPE LTD. (EUROPEAN HEADQUARTERS)**  
 Maidenhead tel: 01628-509-800

**France:**  
**NSK FRANCE S.A.S.**  
 Paris tel: 01-30-57-39-39

**Germany:**  
**NSK DEUTSCHLAND GMBH**  
 Düsseldorf tel: 02102-4810

**Italy:**  
**NSK ITALIA S.P.A.**  
 Milano tel: 0299-5191

**Poland:**  
**NSK EUROPE LTD. WARSAW LIAISON OFFICE**  
 Warsaw tel: 022-645-1525

**NSK STEERING SYSTEMS EUROPE (POLSKA) SP.Z O.O.**  
 Walbrzych tel: 074-664-4101

**NSK NEEDLE BEARING POLAND SP.Z O.O.**  
 Kielce tel: 041-345-2469

**NSK POLSKA SP.Z O.O.**  
 Kielce tel: 041-347-5110

**Spain:**  
**NSK SPAIN S.A.**  
 Barcelona tel: 093-433-5775

**Turkey:**  
**NSK RULMANLARI ORTA DOGU TIC. LTD. STI.**  
 Istanbul tel: 0126-355-0398

**United Kingdom:**  
**NSK EUROPEAN TECHNOLOGY CENTRE**  
 Newark tel: 01636-605-123

**NSK UK Ltd.**  
 Newark tel: 01636-605-123

**North and South America**  
**NSK AMERICAS, INC. (AMERICAN HEADQUARTERS)**  
 Ann Arbor tel: 734-913-7500

**Argentina:**  
**NSK ARGENTINA SRL**  
 Buenos Aires tel: 11-4704-5100

**Brazil:**  
**NSK BRASIL LTDA.**  
 São Paulo tel: 011-3269-4786

**Canada:**  
**NSK CANADA INC.**  
 Toronto tel: 905-890-0740

**Mexico:**  
**NSK RODAMIENTOS MEXICANA, S.A. DE C.V.**  
 Mexico City tel: 55-3682-2900

**United States of America:**  
**NSK CORPORATION**  
 Ann Arbor tel: 734-913-7500

**NSK AMERICAN TECHNOLOGY CENTER**  
 Ann Arbor tel: 734-913-7500

**NSK PRECISION AMERICA, INC.**  
 Franklin tel: 317-738-5000

**NSK STEERING SYSTEMS AMERICA, INC.**  
 Bennington tel: 802-442-5448

**NSK LATIN AMERICA, INC.**  
 Miami tel: 305-477-0605

<As of June 2012>

For the latest information, please refer to the NSK website.

[www.nsk.com](http://www.nsk.com)

NSK Ltd. has a basic policy not to export any products or technology designated as controlled items by export-related laws. When exporting the products in this brochure, the laws of the exporting country must be observed. Specifications are subject to change without notice and without any obligation on the part of the manufacturer. Every care has been taken to ensure the accuracy of the data contained in this brochure, but no liability can be accepted for any loss or damage suffered through errors or omissions. We will gratefully acknowledge any additions or corrections.

For more information about NSK products, please contact: \_\_\_\_\_



NSK used environmentally friendly paper and printing methods for this publication.

CAT. No.E3511b 2013 C-2 Printed in Japan©NSK Ltd. First edition published in SEP. 2009