

PUSH/PULLER 8/12 TONS

INSTRUCTION MANUAL

Hydraulic push-puller for mounting and dismounting

Max. capacity: Pulling – 12 Tons / Pushing – 8 Tons



Read instructions fully before using hydraulic push-pullers.

1. INTRODUCTION

Hydraulic push/pullers are intended for the mounting and dismantling of all kinds of shaft-fitted parts.

Operating conditions
Industrial environment.

2. SAFETY PRECAUTIONS

! WARNING: Carefully follow the instructions when using pullers to prevent personal injury

User requirements

Users require basic technical knowledge. Only trained personnel should use these hydraulic push-pullers.

Do not use the push/pullers if damaged or modified.

- Select the proper size and capacity of puller for the job. This is determined by measuring the “reach” and “spread” of the part to be pulled.
- Align the puller on the same centre line as the part being removed. Failure to align parts correctly can result in a dangerous operating situation because of the high hydraulic pressures that are used.
- To provide protection from injury caused by flying parts should a part break, wrap the work in a protective blanket before applying pressure.
- Safety glasses must be worn at all times by the operator and anyone within sight of the puller.
- Always apply force gradually.
- Do not exceed the hydraulic pressure rating noted on the puller body. Creating pressure beyond rated capacities can result in personal injury. Never use handle extension.
- Always support the object being pulled
- Always ensure the puller jaws are fully engaged with the work piece being pulled.
- Never heat the part to be removed when connected with the puller. Heating can result in damage to the puller.

3. PULLER SET-UP AND OPERATION

- Inspect pullers on arrival. Notify the supplier if shipment is not in good order.

A. Outer pulling:

Principle operation

The piston in the hydraulic cylinder is extended allowing the puller jaws to pull the outer part away from the shaft.

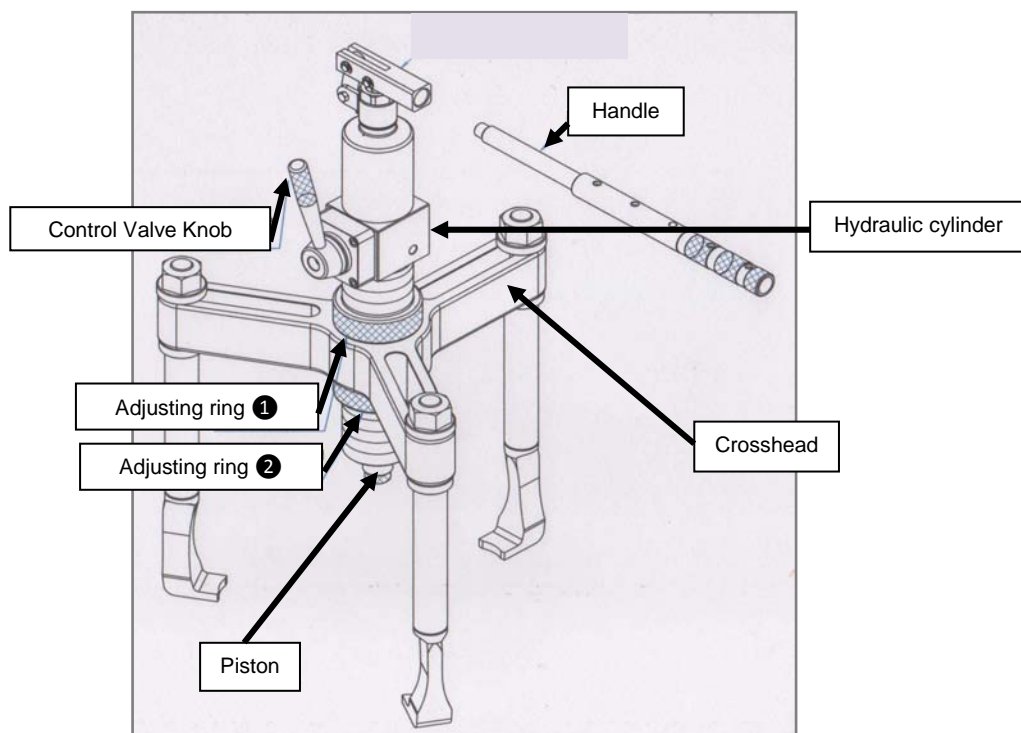

1. Align the puller along the centre line of the object to be pulled.

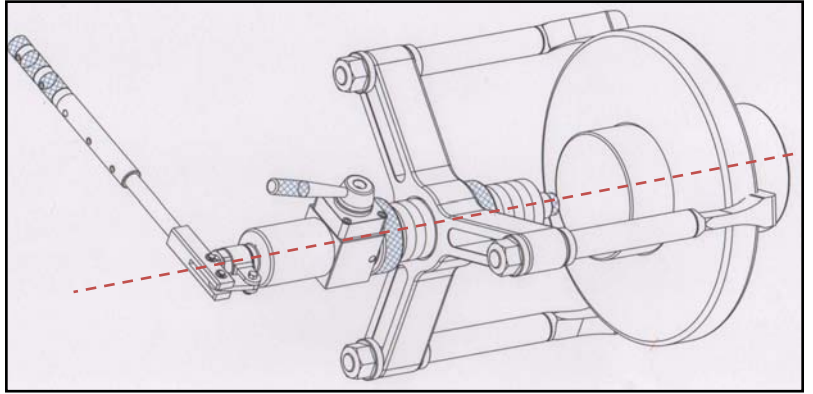

2. Move the adjusting ring ① clear of the cross-head. Rotate the hydraulic cylinder to move it towards the point of support on the shaft moving back the adjusting ring ② as required. Wrap the work with a protective blanket when ready to start pulling.

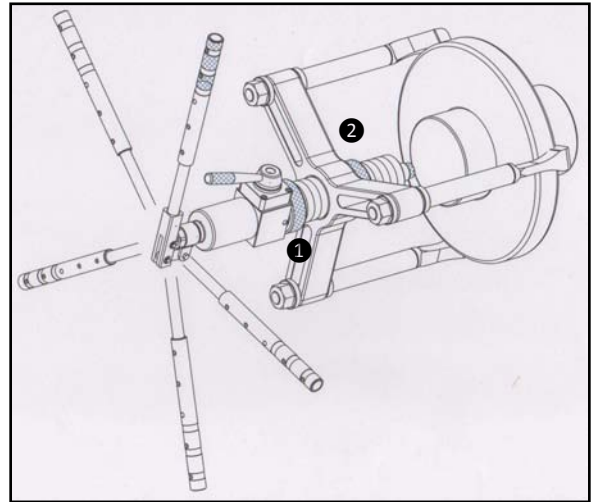

3. Once sure of correct puller alignment, switch the control valve knob to the "Advance" position and start to pump the handle to extend the piston until it touches the shaft centre. Ensure the jaws evenly grip around the part to be pulled. Continue pumping the handle until the object to be pulled is removed.

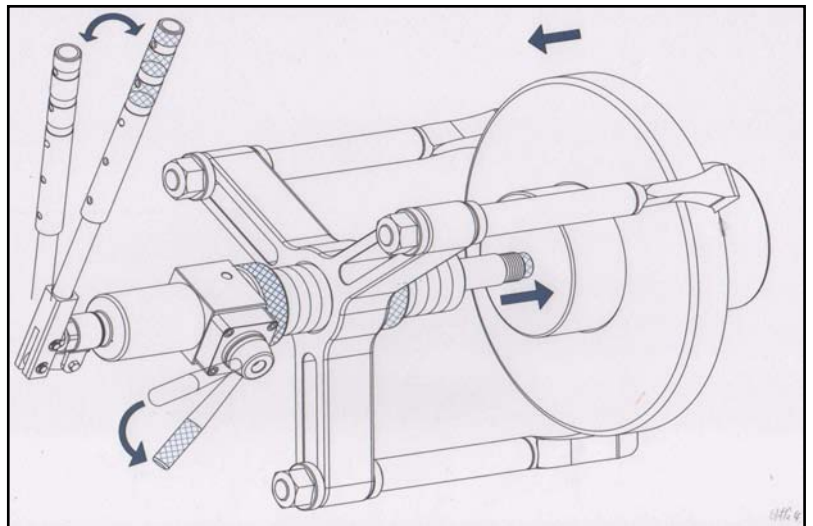

4. After the object has been removed, switch the control valve knob to the "Retract" position to fully retract the piston.

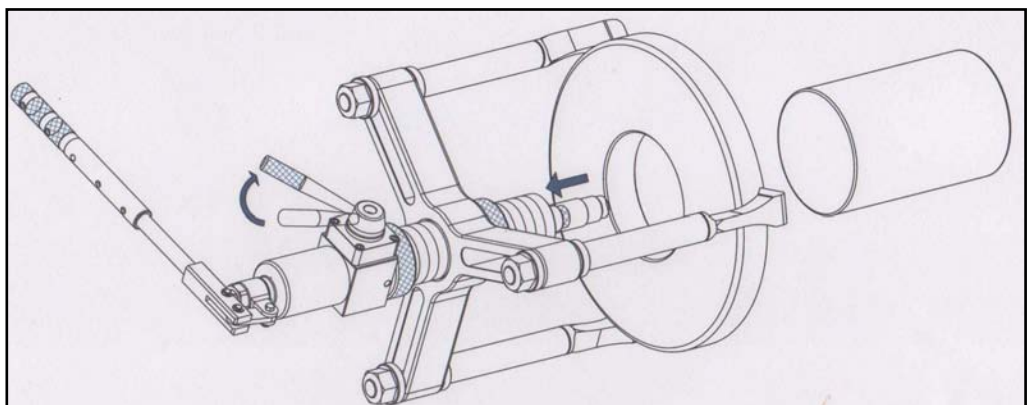

B. Pushing:

1. To mount the "connector" securely at the shaft centre, a threaded hole of the dimensions shown is required.

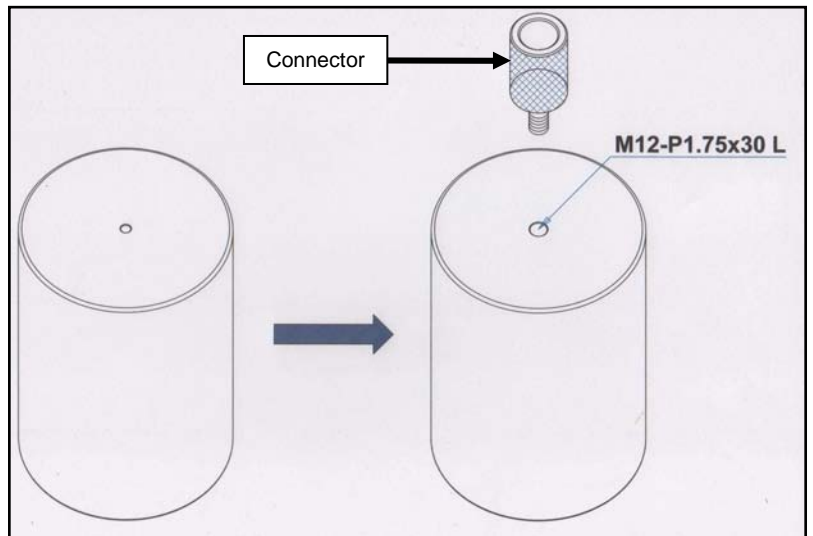

2. Switch the control valve knob to the "Advance" position and pump the handle to extend the piston to its full stroke.

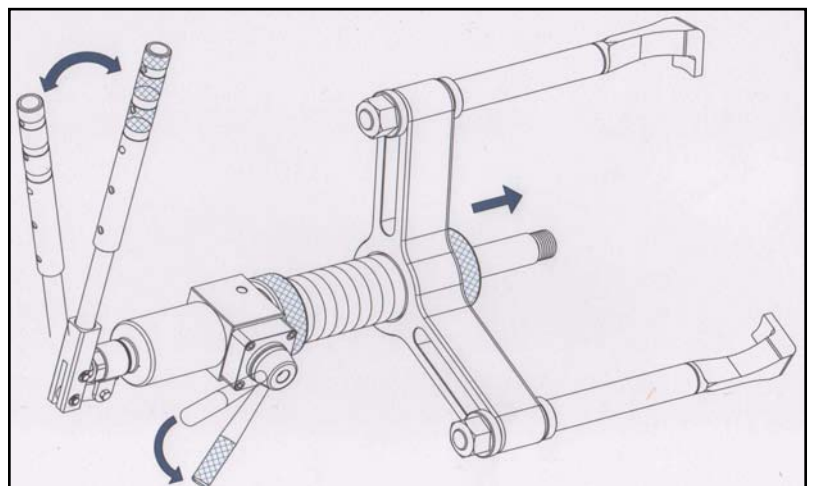

3. Securely connect the piston to the "connector" and position the 3 arms evenly against the inner edge of the object. Adjust the position of the hydraulic cylinder moving the adjusting ring ① as required. Ensure the adjusting ring ② remains clear of the crosshead.

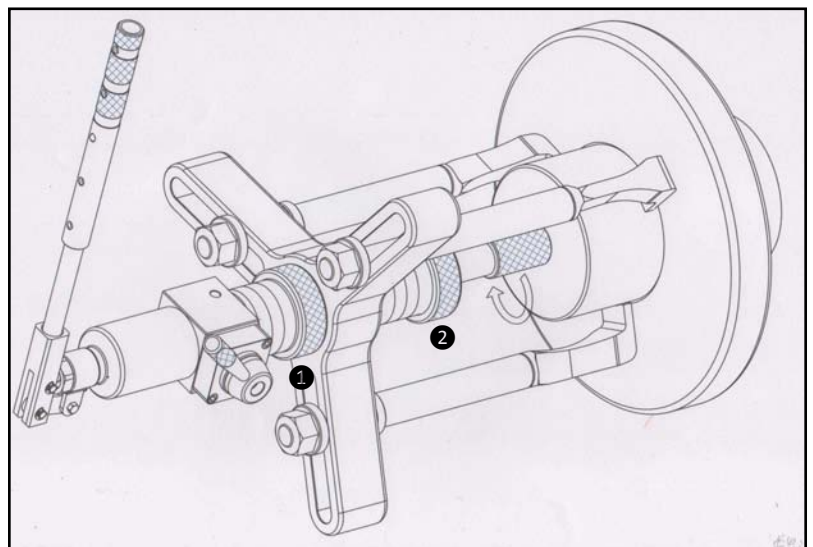

4. Once certain that the push-puller is properly aligned, switch the control valve knob to the "Retract" position. Ensure the 3 jaws are located correctly. Continue pumping with the handle to retract the piston until the object being pushed is at the desired position on the shaft.

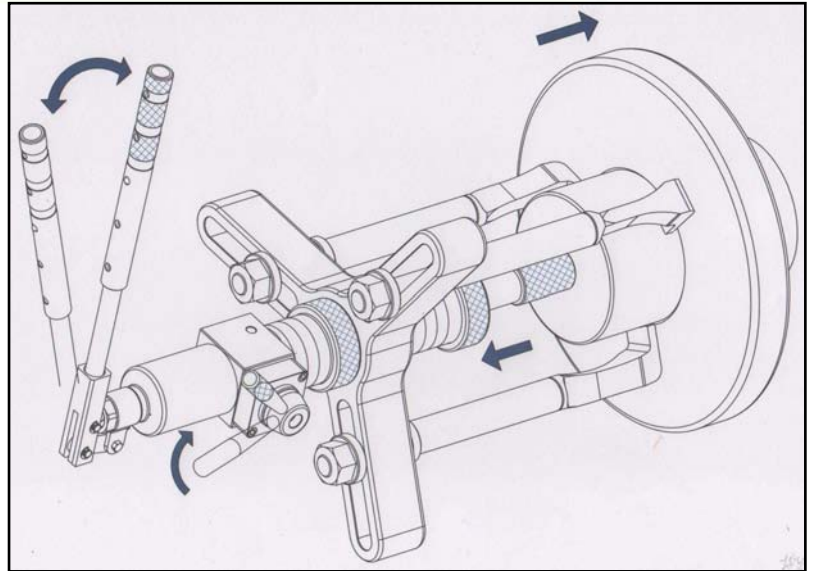

C. Inner pulling:

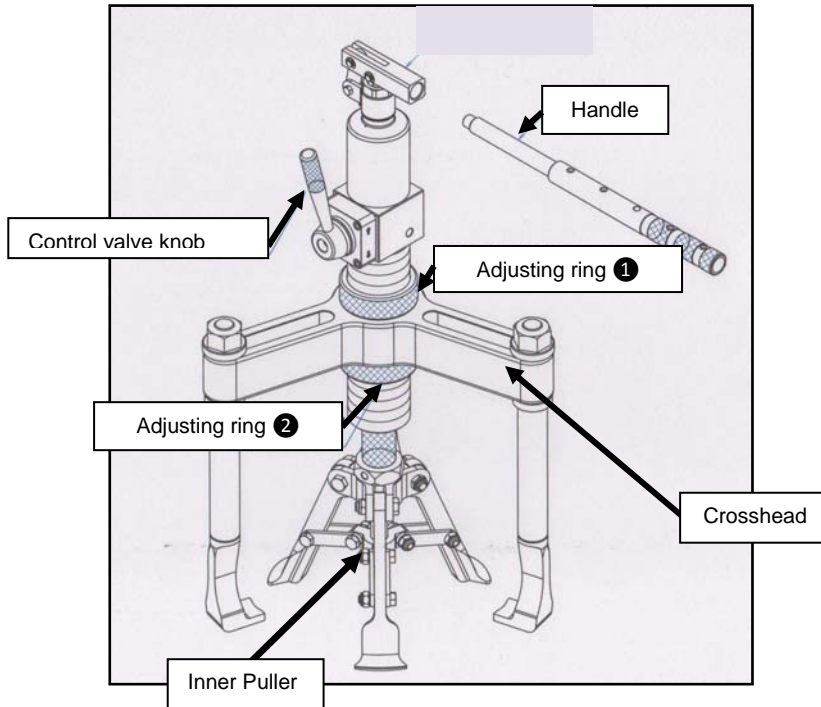

1. Insert the inner puller through the object and turn the hex nut in a clockwise direction to spread the arms until they grip firmly behind the inner edge of the object.

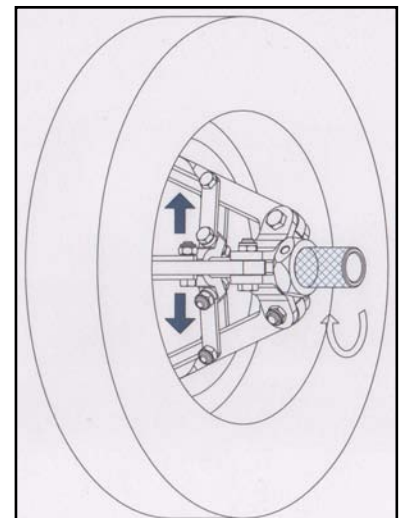

2. Switch the control valve knob to the "Advance" position and start pumping to extend the piston to its full stroke.

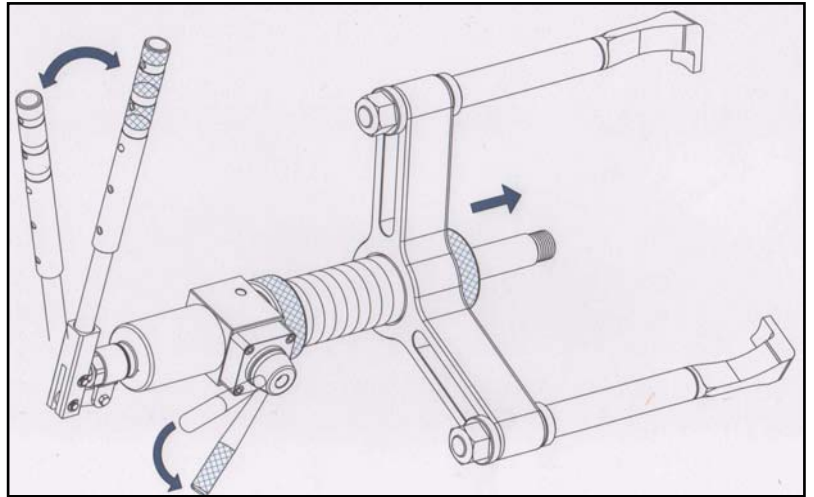

3. Securely connect the piston to the connector and place the three arms evenly against the inner face of the housing. Adjust the position of the hydraulic cylinder using the adjusting ring ①. Ensure that the adjusting ring ② remains clear of the crosshead. Once you are certain that the push-puller is correctly aligned, switch the control valve knob to the "Retract" position and start pumping with the handle to retract the piston. Continue pumping with the handle until the object being pulled has been removed.

