

HYDRAULIC NUT HMV..EBF

INSTRUCTIONS FOR USE



www.ntn-snr.com



With You



Warning



PRESSURE MAX

HMV EBF	10 - 25	→	700	bar
HMV EBF	26 - 40	→	550	bar
HMV EBF	41 - 60	→	450	bar
HMV EBF	62 - 100	→	400	bar
HMV EBF	102 - 120	→	350	bar
HMV EBF	126 - 160	→	300	bar
HMV EBF	170 - 200	→	250	bar

TABLE OF CONTENTS

1.	Safety Instructions	4
2.	Product Description	5
2.1.	Component parts	5
2.2.	Connections	7
2.3.	Principle of operation	7
3.	Spare Parts, Accessories and Technical Data	8
3.1.	Hydraulic Nut	9
3.2.	Accessories	10
3.3.	Technical data HMV..EBF	11
4.	Procedure for the Mounting of Roller Bearings	12
4.1.	Bleeding of the hydraulic system	12
4.2.	Use	12
5.	Possible Mounting / Dismounting Situations for Bearings with Spherical Bore	13
5.1.	Positioning / Axial displacement	14
5.1.1.	Use of a dial gauge (optional)	14
5.1.2.	Mounting the dial gauge with holder	14
6.	Servicing and Maintenance	15
7.	Measurement Table	15-18
8.	Table for Radial Clearance Reduction / Axial Displacement	19
9.	Selection table for hydraulic nut	20
9.1.	For Dismounting / Mounting with Withdrawal Sleeve	20-21
9.2.	For Dismounting / Mounting with Adapter Sleeve	22
10.	Notes	23

1. SAFETY INSTRUCTIONS

Inappropriate handling of hydraulic nuts of the type HMV..EBF can lead to serious injuries and compromise safety.



CAUTION!

The safety instructions provided must be adhered to!

- The operating staff must be authorised!
- The safety instructions and these operating instructions must be complied with in full. They have to be stored with the tools!
- The hydraulic nuts, pump with hydraulic pipe as well as all accessories must be carefully checked for damage before operation - defective or worn parts pose a serious risk and may not be used under any circumstances!
- It must be ensured that there is no air in the hydraulic system - it must be completely bled before operation!
- Never exceed the maximum stroke of the hydraulic nut. (indicated by a Yellow Marker)
- A Pressure gauge must always be connected to check the work pressure!
- The hydraulic nut may only be operated with a manual pump!
- Dirt and oil residues must always be instantly removed!
- Protective goggles must always be worn!
- Changes to the components are not permitted!
- Only use NTN-SNR original spare parts!
- Always use clean hydraulic oil!



CAUTION!

Referring to chapter 2 of this operating instruction a different or additional use of the hydraulic nut is not permitted. The manufacturer is not responsible for damage resulting from inappropriate use. The user retains the overall responsibility and is alone in bearing the risk.

2. PRODUCT DESCRIPTION

The hydraulic nut HMV.EBF is a tool that has been designed to permit the simple mounting and dismounting of rolling bearings with tapered bores. The parts to be installed can be moved into the desired position safely and without excessive use of force.

Main area of application

Mounting of rolling bearings (bore taper 1:12 / 1:30) on tapered shafts, adapter sleeves or withdrawal sleeves.

2.1. COMPONENT PARTS

The hydraulic nut mainly consists of the ring body and ring piston. The ring body has an internal thread that is used to screw it onto a shaft or sleeve thread. Hydraulic oil under pressure is used to operate the piston

Two O-rings are used to seal the piston.

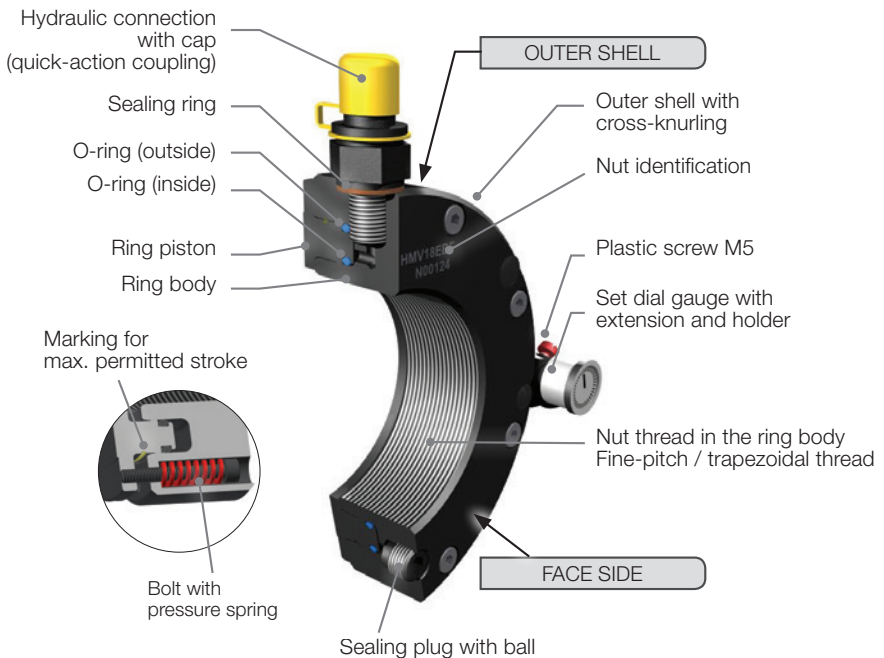

Operating instructions

NTN-SNR HYDRAULIC NUT HMV..EBF

One G1/4 threaded hole is provided in the end face as well as in the outer shell to connect a hydraulic pipe. The threaded hole in the end face is closed at the factory with a sealing plug with ball (*Item 1*). A fast-action coupling (*Item 2*) is screwed into the threaded hole in the outer shell.

Cross-knurling is provided on the outer shell on the hydraulic nut to make it easier to screw it onto a shaft or sleeve thread.

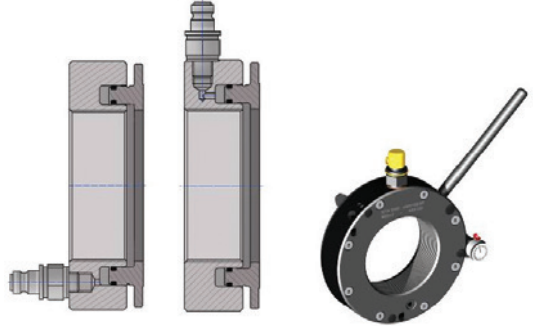

Optional connection at:
Face side or Outer shell

Tommy bar

The attached, standard mounting lever (*Item 6*) can also be used for easy turning of the nut. It is an installation aid and is pushed into the blind holes in the outer shell. Bolts with pressure springs (*Item 10*) are circumferentially mounted within the hydraulic nut. They ensure that the piston returns and helps to return the oil into the reservoir of the pump. The piston does not need to be pushed back manually.

2.2. CONNECTIONS

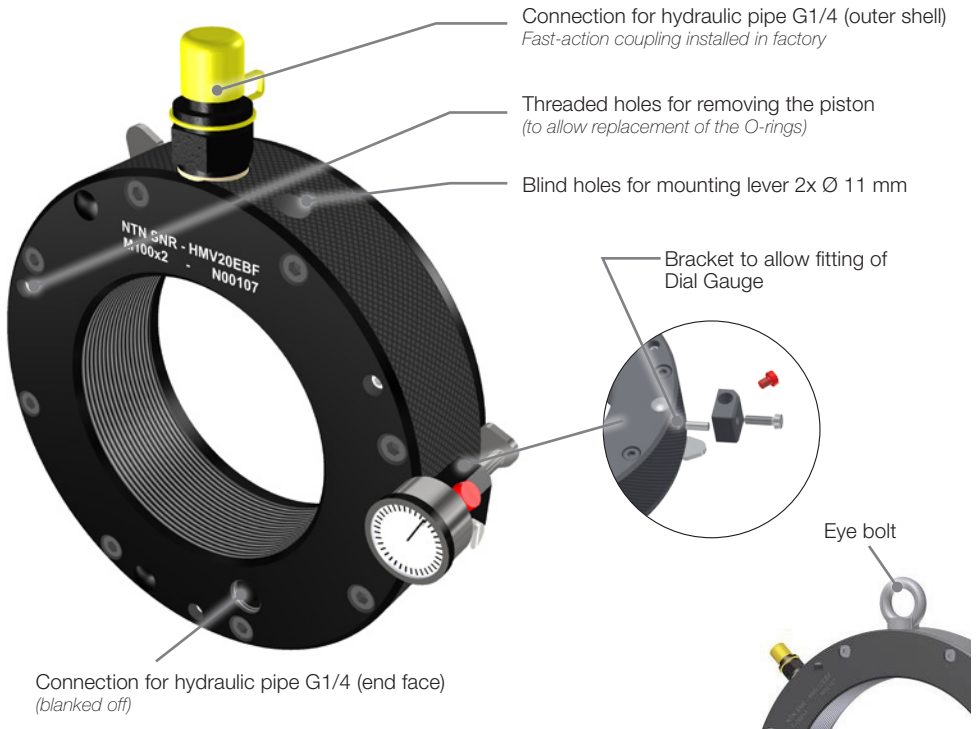

Hydraulic nuts from size HMV60EBF onwards are equipped with additional threaded holes in the outer shell. The eye bolt included in the delivery can be installed there for better handling.

2.3. PRINCIPLE OF OPERATION

Oil pressure inside the ring body is created by a hydraulic pump and causes the axial advance of the ring piston. This displacement pushes the rolling bearing onto its tapered seat. In order to ensure precise positioning of the rolling bearing, drive up distance should be checked by using a dial gauge.

The ring piston is automatically pushed back to the starting position when the pump pressure is released. The oil automatically flows back into the reservoir of the pump.

3. SPARE PARTS, ACCESSORIES AND TECHNICAL DATA

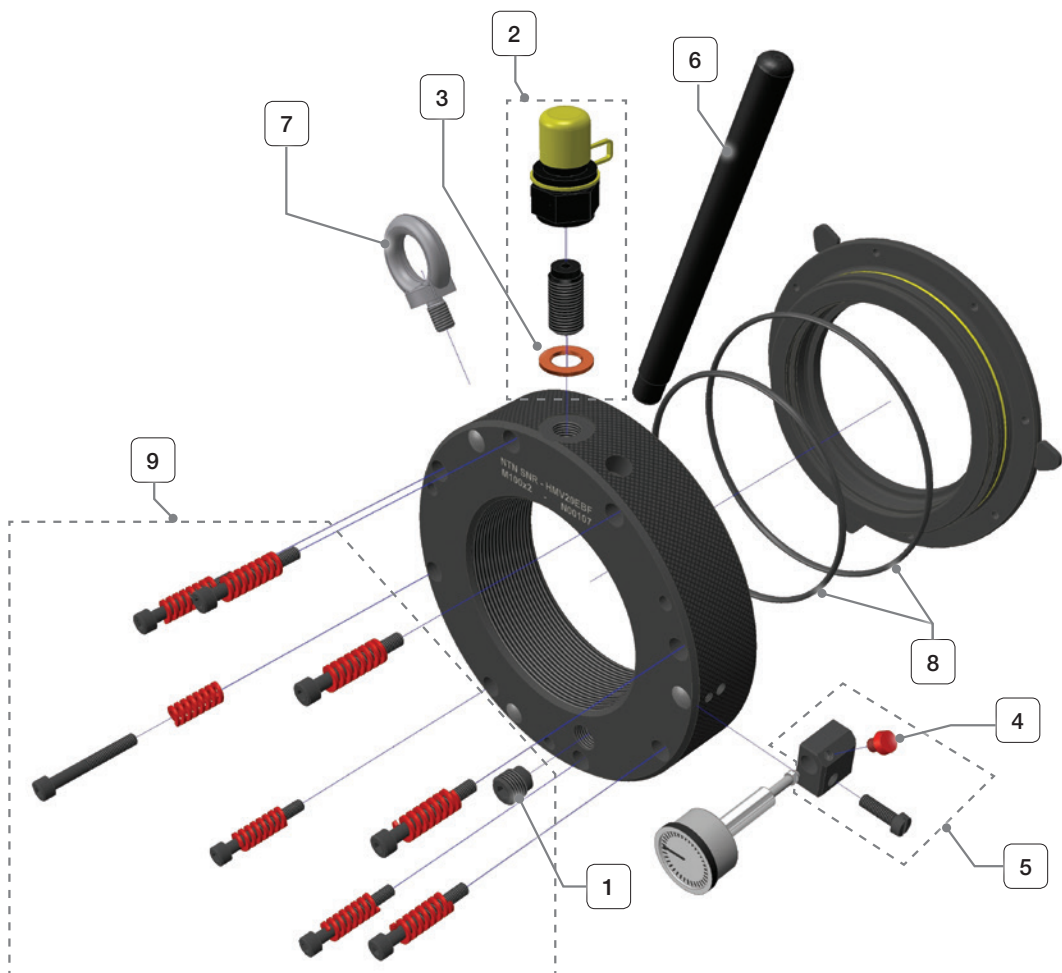

3.1. HYDRAULIC NUT

Pos	Article		Notice
1	TOOL HMV BALL PLUG 1/4	Sealing plug with ball *	
2	TOOL HMV NIPPLE 1/4	Hydraulic connection *	Consisting of: 1x quick-action coupling with cover 1x adapter thread 1x sealing ring
3	TOOL HMV SW 1/4	Sealing ring for hydraulic connection *	
4	TOOL HMV PAS M5	Plastic set screw for dial gauge locking *	
5	TOOL HMV DG HOLDER	Dial gauge holder *	Consisting of: 1x M5 plastic set screw 1x M5 Knurled head screw 1x Holder with centre pin
6	TOOL HMV TBAR 11x150 TOOL HMV TBAR 16x200	Tommy bar *	HMV10EBF - HMV58EBF: 11x150 HMV60EBF - HMV200EBF: 16x200
7	TOOL HMV EBO M12 TOOL HMV EBO M16	Eye bolt DIN 580	HMV60EBF - HMV130EBF: M12 HMV134EBF - HMV200EBF: M16
8	TOOL HMV... PISTON SEALS	Set of piston seals	Consisting of: 1x O-ring (inside) 1x O-ring (outside)
9	TOOL HMV... SET-PSK	Set of pressure springs	

* Parts included in delivery

3.2. ACCESSORIES

Order Number	Description
TOOL PUMP SET 700B-0.3L / Pump with accessories	Hydraulic pump with 0.3 l oil volume Incl. hydraulic hose, connection nipple, pressure gauge (analogue), 0.3 l pre-filled with hydraulic oil max. working pressure 700 bar
TOOL PUMP SET 700B-0.9L / Pump with accessories	Hydraulic pump with 0.9 l oil volume Incl. hydraulic hose, connection nipple, pressure gauge (analogue), 0.9 pre-filled with hydraulic oil max. working pressure 700 bar
TOOL PUMP SET 1500B-2.5L / Pump with accessories	Pump with accessories Hydraulic pump with 2.55 l oil volume Incl. hydraulic hose, connection nipple, pressure gauge (analogue), 2.55 l pre-filled with hydraulic oil max. working pressure 1,500 bar
TOOL PUMP GAUGE 700	Gauge up to max. 700 bar (analogue)
TOOL HYDRAULIC OIL 1L	Hydraulic fluid 1.0 l
TOOL FEELER GAUGES 100 TOOL FEELER GAUGES 150 TOOL FEELER GAUGES 300	Feeler gauge (length 100 mm) Feeler gauge (length 150 mm) Feeler gauge (length 300 mm)
TOOL DIAL GAUGE 050	Dial gauge for a displacement distance up to 5 mm
TOOL DIAL GAUGE 100	Dial gauge for a displacement distance up to 10 mm
TOOL DIAL EXTENSION SET	Extension adapter set for dial gauge

3.3. TECHNICAL DATA HMV..EBF

Nut thread	HMV 10 EBF to HMV 40 EBF HMV 41 EBF to HMV 200 EBF	ISO 965/III-1980, Tolerance class 6H ISO 2901-1977, Tolerance class 7H
Required pump volume for hydraulic nuts	HMV 10 EBF to HMV 54 EBF HMV 56 EBF to HMV 92 EBF HMV 94 EBF to HMV 200 EBF	TOOL PUMP SET 700B-0,3L TOOL PUMP SET 700B-0,9L TOOL PUMP SET 1500B-2,5L
Thread size of eye bolt	HMV 60 EBF to HMV 130 EBF > HMV 130 EBF	M12 M16
Fastening torque Sealing plug with ball		45 Nm
Max. permitted operating pressure* at max. piston stroke	HMV 10 EBF to HMV 25 EBF HMV 26 EBF to HMV 40 EBF HMV 41 EBF to HMV 60 EBF HMV 62 EBF to HMV 100 EBF HMV 102 EBF to HMV 120 EBF HMV 126 EBF to HMV 160 EBF HMV 170 EBF to HMV 200 EBF	700 bar 550 bar 450 bar 400 bar 350 bar 300 bar 250 bar

* The required operating pressure for mounting and dismounting of rolling bearings is depending on various factors such as size of the bearing, bearing seat quality, numbers of contact surfaces as well as the weight of the rolling bearing.

4. PROCEDURE FOR THE MOUNTING OF ROLLER BEARINGS

Push the bearing by hand as far as possible onto the tapered seat and screw the hydraulic nut onto the thread of the shaft or the sleeve. Ensure that the inner and outer threads are aligned with each other when positioning the nut. It is recommended to use an assembly paste. The start of the thread is marked on the outer shell of the ring body to ease the positioning of larger hydraulic nuts (from HMV90EBF onwards).

Caution: Damage due to cross threading must be avoided.

4.1. BLEEDING OF THE HYDRAULIC SYSTEM

Note:

The hydraulic system must be bled when the nut is used for the first time and after each de-installation of a hydraulic connection.

Screw the whole thread length of the hydraulic nut onto the shaft or sleeve thread and connect the hydraulic pipe to the appropriate hydraulic connection (Item 2).

Turn the sealing plug with ball (Item 1) to the highest position and loosen it slightly. Then pump oil, using the hydraulic pump, until the oil exits without bubbles. Thereafter, firmly close the sealing plug (max. fastening torque 45 Nm).

4.2. USE

Screw the hydraulic nut against the rolling bearing until the full annular piston bears evenly on the bearing. The piston must be in its start position and must be fully inserted in the annular body. To absorb the forces that arise during the displacement operation via the thread, a minimum overlap with the mating thread of at least 85% must be guaranteed.

Thereafter, connect the hydraulic pipe to the appropriate hydraulic connection.

5. POSSIBLE MOUNTING / DISMOUNTING SITUATIONS FOR BEARINGS WITH SPHERICAL BORE

Mounting

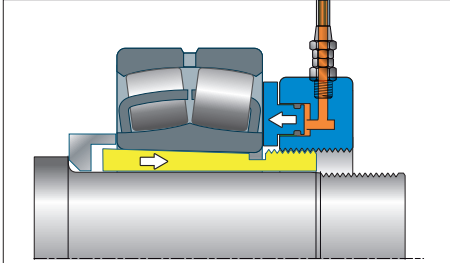

Mounting a rolling bearing on an adapter sleeve on a cylindrical shaft. The rolling bearing is supported against a stop ring or shaft shoulder.

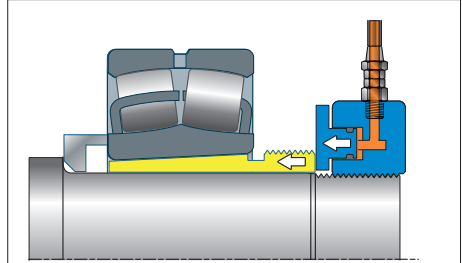

Mounting a bearing on a withdrawal sleeve on a cylindrical shaft with thread. Bearing supported against a stop ring or shaft shoulder.

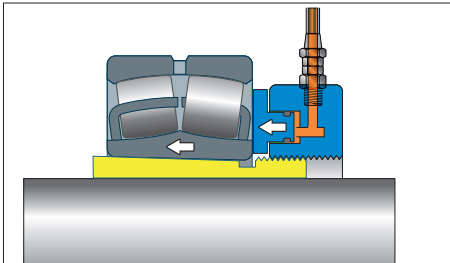

Mounting a bearing on an adapter sleeve on cylindrical shaft.

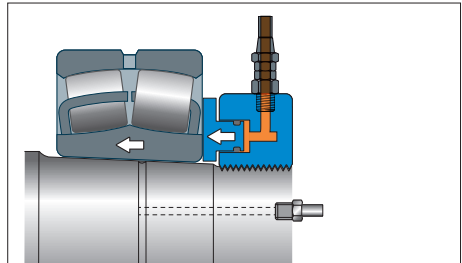

Mounting a bearing on tapered shaft seat

Dismounting

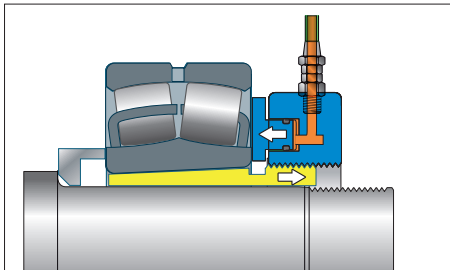

Dismounting a rolling bearing on a withdrawal sleeve. The hydraulic nut is acting against the inner ring.

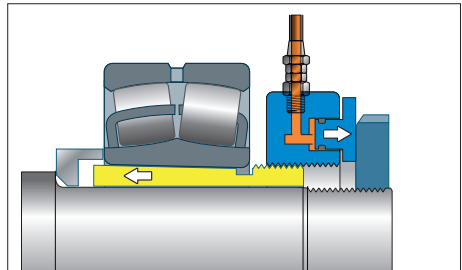

Dismounting a rolling bearing on an adapter sleeve. The hydraulic nut is acting against a nut mounted on the shaft.

5.1. POSITIONING / AXIAL DISPLACEMENT

5.1.1. Use of a dial gauge

For the mounting process of a roller bearing a dial gauge can be used for measuring the axial displacement. Therefore a dial gauge holder (item 5) can be installed on the face side of the ring body.

(The holder is included to the scope of delivery)

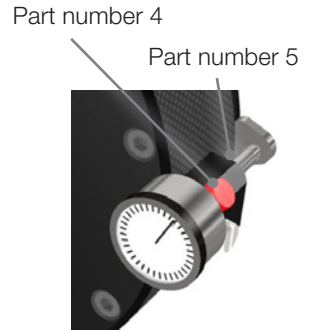

5.1.2. Mounting the dial gauge with holder

The dial gauge holder (item 5) is to be installed only when the HMV is screwed on the thread and the ring piston rests fully against the bearing. This is to prevent injury while turning the nut and to avoid damage to the sensitive dial gauge.

The dial gauge holder is mounted radially with the cap head screw (M5) in one of the three possible positions on the ring body. The dowel pin in the holder helps to locate its position. Insert the dial gauge with the extension into the bore of the holder until the tip of the extension contacts the measurement surface appropriate of the ring piston.

Lock the dial gauge with the plastic screw (M5) (Item 4) so that it cannot slide. Turn the adjustment ring of the dial gauge to the zero position set and establish what axial displacement is required for the bearing to be fitted.

Note

The axial displacement depends on the clearance group and the size of the roller bearing. The values for spherical roller-bearings are provided in the table shown in chapter 8.

Hydraulic oil is now pumped into the hydraulic nut using a hand pump. The ring piston moves the roller bearing onto the sleeve or the tapered bearing seat.

The pumping process is to be continued until the prescribed displacement has been reached. It is recommended to make a final inspection of the internal clearance in the mounted position after the pressure has been released using feeler gauges.



CAUTION!

A circumferential, yellow marking on the ring piston shows that the maximum permitted stroke has been reached. As soon as this marker is aligned with the edge of the ring body, the ring piston may not be pumped out of the ring body any further (risk of injury / damage to the hydraulic nut)

Open the pressure release valve to allow the removal of the nut. The annular piston automatically travels back to its starting position on the hand pump and presses the hydraulic oil out of the hydraulic nut and into the pump as it does so. The hydraulic nut can now be dismantled. The press-fitted assembly must now be fastened with a lock nut and a lock washer.

6. SERVICING AND MAINTENANCE

Dirt and oil residues must be removed from the surfaces after every use to ensure flawless and safe functioning of the hydraulic nut and the hydraulic components.

Hydraulic connections and threads must be checked for possible damage.

The hydraulic connections must be safely capped with covers after use and protected against the penetration of dirt.

Make sure that the employed hydraulic oil is clean and complies with the required specifications (ISO 11158). The pump tank must always be filled with sufficient oil.

If hydraulic oil emerges from the hydraulic nut during use, the O- rings may be defective (or the maximum stroke of the nut has been reached check if yellow mark is visible).

For replacement of the O- rings, please return the hydraulic nut to NTN-SNR.

For further information, please contact NTN-SNR.

7. MEASUREMENT TABLE

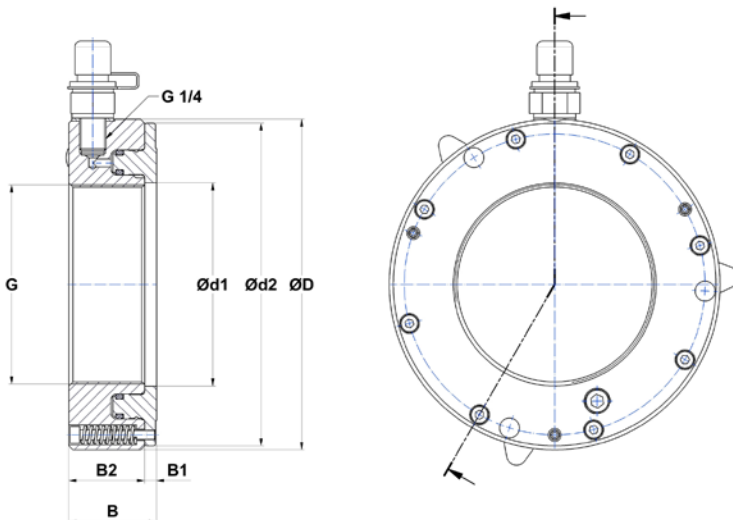

Operating instructions

NTN-SNR HYDRAULIC NUT HMV..EBF

Size	Thread	External diameter	Total width	Piston diameter	Permitted piston stroke	Flange width	Body width	Diameter	Piston surface area	Weight
		mm	mm	mm	mm	mm	mm	mm	mm ²	kg
	G	D	B	max. d2		B1	B2	d1		
HMV 10 EBF	M 50x1,5	114	43	112	5	5	38	52	2800	2,8
HMV 11 EBF	M 55x2	120	43	118	5	5	38	57	3100	3,1
HMV 12 EBF	M 60x2	125	43	123	5	5	38	62	3300	3,3
HMV 13 EBF	M 65x2	130	43	128	5	5	38	67	3500	3,4
HMV 14 EBF	M 70x2	135	43	133	5	5	38	72	3700	3,6
HMV 15 EBF	M 75x2	140	43	138	5	5	38	77	3900	3,8
HMV 16 EBF	M 80x2	145	43	143	5	5	38	82	4100	3,9
HMV 17 EBF	M 85x2	150	43	148	5	5	38	87	4300	4,1
HMV 18 EBF	M 90x2	156	43	152	5	5	38	92	4400	4,3
HMV 19 EBF	M 95x2	162	43	158	5	5	38	97	4800	4,5
HMV 20 EBF	M 100x2	166	44	162	5	6	38	102	4800	4,7
HMV 21 EBF	M 105x2	172	44	168	5	6	38	107	5200	5,0
HMV 22 EBF	M 110x2	178	44	174	5	6	38	112	5700	5,3
HMV 23 EBF	M 115x2	182	44	178	5	6	38	117	5600	5,4
HMV 24 EBF	M 120x2	188	44	184	5	6	38	122	6100	5,6
HMV 25 EBF	M 125x2	192	44	188	5	6	38	127	6000	5,7
HMV 26 EBF	M 130x2	198	44	194	5	6	38	132	6500	6,0
HMV 27 EBF	M 135x2	204	44	200	5	6	38	137	7000	6,3
HMV 28 EBF	M 140x2	208	45	204	5	7	38	142	6900	6,5
HMV 29 EBF	M 145x2	214	46	210	5	7	39	147	7400	6,9
HMV 30 EBF	M 150x2	220	46	216	5	7	39	152	7900	7,3
HMV 31 EBF	M 155x3	226	46	222	5	7	39	157	8500	7,7
HMV 32 EBF	M 160x3	232	47	228	6	7	40	162	9000	8,2
HMV 33 EBF	M 165x3	238	47	234	6	7	40	167	9600	8,5
HMV 34 EBF	M 170x3	244	48	240	6	7	41	172	10200	9,0
HMV 36 EBF	M 180x3	256	48	252	6	7	41	182	11400	9,8
HMV 38 EBF	M 190x3	270	50	266	7	8	42	192	12000	11,3
HMV 40 EBF	M 200x3	282	51	278	8	8	43	202	12500	12,4
HMV 41 EBF	Tr 205x4	288	51	284	8	8	43	209	12800	12,8
HMV 42 EBF	Tr 210x4	294	52	290	8	8	44	212	13100	13,6
HMV 43 EBF	Tr 215x4	300	52	296	8	8	44	219	13300	14,0
HMV 44 EBF	Tr 220x4	306	52	302	8	8	44	224	13600	14,5
HMV 45 EBF	Tr 225x4	312	53	308	8	8	45	229	13900	15,2
HMV 46 EBF	Tr 230x4	318	53	314	8	8	45	234	14200	15,7
HMV 47 EBF	Tr 235x4	326	54	322	9	8	46	239	15600	16,8
HMV 48 EBF	Tr 240x4	330	55	326	9	9	46	244	16400	17,2
HMV 50 EBF	Tr 250x4	342	55	338	9	9	46	254	17000	18,2
HMV 52 EBF	Tr 260x4	356	56	352	9	9	47	264	17500	20,2
HMV 54 EBF	Tr 270x4	368	57	364	10	9	48	274	18100	21,7
HMV 56 EBF	Tr 280x4	380	58	376	10	9	49	284	19800	23,3
HMV 58 EBF	Tr 290x4	390	58	386	10	9	49	294	20400	24,0
HMV 60 EBF	Tr 300x4	410	61	406	10	10	51	304	23900	29,2

Operating instructions

NTN-SNR HYDRAULIC NUT HMV..EBF

Size	Thread	External diameter	Total width	Piston diameter	Permitted piston stroke	Flange width	Body width	Diameter	Piston surface area	Weight
		mm	mm	mm	mm	mm	mm	mm	mm ²	kg
	G	D	B	max. d2		B1	B2	d1		
HMV 62 EBF	Tr 310x5	420	62	416	11	10	52	314	24600	30,9
HMV 64 EBF	Tr 320x5	430	63	426	11	10	53	324	25300	32,1
HMV 66 EBF	Tr 330x5	440	63	436	12	10	53	334	26000	33,0
HMV 68 EBF	Tr 340x5	450	64	446	12	10	54	344	26700	34,4
HMV 69 EBF	Tr 345x5	460	64	456	12	10	54	349	30200	36,5
HMV 70 EBF	Tr 350x5	470	66	466	12	10	56	354	31000	39,8
HMV 72 EBF	Tr 360x5	480	66	476	13	10	56	364	33400	40,7
HMV 73 EBF	Tr 365x5	485	68	481	13	11	57	369	33800	42,4
HMV 74 EBF	Tr 370x5	490	68	486	13	11	57	374	34300	42,9
HMV 76 EBF	Tr 380x5	500	69	496	14	11	58	384	35100	44,6
HMV 77 EBF	Tr 385x5	505	69	501	14	11	58	389	35500	45,1
HMV 80 EBF	Tr 400x5	530	71	526	14	11	60	404	35300	52,8
HMV 82 EBF	Tr 410x5	545	72	541	14	11	61	414	36900	57,0
HMV 84 EBF	Tr 420x5	555	72	551	14	11	61	424	39300	57,9
HMV 86 EBF	Tr 430x5	565	73	561	14	11	62	434	41700	59,9
HMV 88 EBF	Tr 440x5	575	73	571	14	12	62	444	40900	60,8
HMV 90 EBF	Tr 450x5	590	75	586	15	12	64	454	45100	66,3
HMV 92 EBF	Tr 460x5	600	76	596	15	12	64	464	46000	68,3
HMV 94 EBF	Tr 470x5	610	77	606	15	12	65	474	48600	70,4
HMV 96 EBF	Tr 480x5	620	77	616	16	12	65	484	50400	71,7
HMV 98 EBF	Tr 490x5	640	78	636	16	12	66	494	54300	79,9
HMV 100 EBF	Tr 500x5	650	79	646	16	12	67	504	55300	82,4
HMV 102 EBF	Tr 510x6	660	80	656	17	12	68	514	56300	85,7
HMV 104 EBF	Tr 520x6	670	81	666	17	13	68	524	57200	88,3
HMV 106 EBF	Tr 530x6	680	82	676	17	13	69	534	50500	90,4
HMV 108 EBF	Tr 540x6	690	82	686	17	13	69	544	52300	91,9
HMV 110 EBF	Tr 550x6	705	83	701	17	13	70	554	55200	98,0
HMV 112 EBF	Tr 560x6	715	84	711	18	13	71	564	56100	100,3
HMV 114 EBF	Tr 570x6	725	85	721	18	13	72	574	57000	103,2
HMV 116 EBF	Tr 580x6	735	85	731	18	13	72	584	57900	104,8
HMV 120 EBF	Tr 600x6	760	86	756	19	13	73	604	65200	113,1
HMV 126 EBF	Tr 630x6	790	88	786	19	14	74	634	68100	120,8
HMV 130 EBF	Tr 650x6	810	89	806	19	14	75	654	70100	125,7
HMV 134 EBF	Tr 670x6	840	90	836	22	14	76	674	80800	139,6
HMV 138 EBF	Tr 690x6	860	91	856	22	14	77	694	83000	145,2
HMV 142 EBF	Tr 710x7	880	93	876	23	15	78	714	85200	152,9
HMV 150 EBF	Tr 750x7	920	94	916	23	15	79	754	89600	162,4
HMV 160 EBF	Tr 800x7	970	96	966	25	16	80	804	95100	175,6
HMV 170 EBF	Tr 850x7	1030	99	1026	26	16	83	854	115600	203,2
HMV 180 EBF	Tr 900x7	1100	103	1096	28	17	86	904	153900	247,5
HMV 190 EBF	Tr 950x8	1150	103	1146	28	17	86	954	161800	261,0
HMV 200 EBF	Tr 1000x8	1200	105	1196	30	17	88	1004	169600	279,0

Operating instructions

NTN-SNR HYDRAULIC NUT HMVC..EBF

Size	Thread	Numbers of thread	Outside diameter	Total width	Piston diameter	Permitted piston stroke	Flange width	Body width	Diameter	Piston surface area	Weight
		inch	inch	inch	inch	inch	inch	inch	inch	inch ²	Kg
HMVC ... EBF	G		D	B	max. d2		B1	B2	d1		
10	1,967	18	4,5	1,7	4,4	0,20	0,20	1,5	2,0	4,4	6,3
11	2,157	18	4,7	1,7	4,6	0,20	0,20	1,5	2,2	4,8	6,8
12	2,360	18	4,9	1,7	4,8	0,20	0,20	1,5	2,4	5,1	7,2
13	2,548	18	5,1	1,7	5,0	0,20	0,20	1,5	2,6	5,4	7,6
14	2,751	18	5,3	1,7	5,2	0,20	0,20	1,5	2,8	5,8	7,9
15	2,933	12	5,5	1,7	5,4	0,20	0,20	1,5	3,0	6,1	8,3
16	3,137	12	5,7	1,7	5,6	0,20	0,20	1,5	3,2	6,4	8,7
17	3,340	12	5,9	1,7	5,8	0,20	0,20	1,5	3,4	6,7	9,1
18	3,527	12	6,1	1,7	6,0	0,20	0,20	1,5	3,6	6,8	9,5
19	3,730	12	6,4	1,7	6,2	0,20	0,20	1,5	3,8	7,5	10,0
20	3,918	12	6,5	1,7	6,4	0,20	0,24	1,5	4,0	7,5	10,4
21	4,122	12	6,8	1,7	6,6	0,20	0,24	1,5	4,2	8,1	11,0
22	4,325	12	7,0	1,7	6,9	0,20	0,24	1,5	4,4	8,8	11,6
24	4,716	12	7,4	1,7	7,2	0,20	0,24	1,5	4,8	9,4	12,4
26	5,106	12	7,8	1,7	7,6	0,20	0,24	1,5	5,2	10,1	13,2
28	5,497	12	8,2	1,8	8,0	0,20	0,28	1,5	5,6	10,7	14,3
30	5,888	12	8,7	1,8	8,5	0,20	0,28	1,5	6,0	12,3	16,0
32	6,284	8	9,1	1,9	9,0	0,24	0,28	1,6	6,4	14,0	18,0
34	6,659	8	9,6	1,9	9,4	0,24	0,28	1,6	6,8	15,8	19,9
36	7,066	8	10,1	1,9	9,9	0,24	0,28	1,6	7,2	17,7	21,5
38	7,472	8	10,6	2,0	10,5	0,28	0,31	1,7	7,6	18,5	24,9
40	7,847	8	11,1	2,0	10,9	0,31	0,31	1,7	8,0	19,4	27,3
44	8,628	8	12,0	2,0	11,9	0,31	0,31	1,7	8,8	21,1	31,9
46	9,125	8	12,5	2,1	12,4	0,31	0,31	1,8	9,2	21,9	34,7
48	9,442	6	13,0	2,2	12,8	0,35	0,35	1,8	9,6	25,4	37,8
52	10,192	6	14,0	2,2	13,9	0,35	0,35	1,9	10,4	27,2	44,4
56	11,004	6	15,0	2,3	14,8	0,39	0,35	1,9	11,2	30,7	51,4
60	11,785	6	16,1	2,4	16,0	0,39	0,39	2,0	12,0	37,0	64,4
64	12,562	6	16,9	2,5	16,8	0,43	0,39	2,1	12,8	39,2	70,8
68	13,339	5	17,7	2,5	17,6	0,47	0,39	2,1	13,5	41,4	75,7
72	14,170	5	18,9	2,6	18,7	0,51	0,39	2,2	14,3	51,8	89,7
76	14,957	5	19,7	2,7	19,5	0,55	0,43	2,3	15,1	54,4	98,2
80	15,745	5	20,9	2,8	20,7	0,55	0,43	2,4	15,9	54,8	116,4
84	16,532	5	21,9	2,8	21,7	0,55	0,43	2,4	16,7	60,8	127,7
88	17,319	5	22,6	2,9	22,5	0,55	0,43	2,4	17,5	63,4	134,1
92	18,107	5	23,6	3,0	23,5	0,59	0,47	2,5	18,3	71,3	150,6
96	18,894	5	24,4	3,0	24,3	0,63	0,47	2,6	19,1	78,2	158,0
100	19,682	5	25,6	3,1	25,4	0,63	0,47	2,6	19,8	85,7	181,6
106	20,867	4	26,8	3,2	26,6	0,67	0,51	2,7	21,0	78,3	199,4
112	22,048	4	28,1	3,3	28,0	0,71	0,51	2,8	22,2	87,0	221,1
120	23,623	4	29,9	3,4	29,8	0,75	0,51	2,9	23,8	101,0	249,2
126	24,804	4	31,1	3,5	30,9	0,75	0,55	2,9	25,0	105,6	266,4
134	26,379	4	33,1	3,5	32,9	0,87	0,55	3,0	26,5	125,3	307,8
142	27,961	3	34,6	3,7	34,5	0,91	0,59	3,1	28,1	132,1	337,1
150	29,536	3	36,2	3,7	36,1	0,91	0,59	3,1	29,7	138,9	358,1
160	31,504	3	38,2	3,8	38,0	0,98	0,63	3,1	31,7	147,4	387,1
170	33,473	3	40,6	3,9	40,4	1,02	0,63	3,3	33,6	179,2	448,0
180	35,441	3	43,3	4,1	43,1	1,10	0,67	3,4	35,6	238,6	545,6
190	37,410	3	45,3	4,1	45,1	1,10	0,67	3,4	37,6	250,8	575,3

8. TABLE FOR RADIAL CLEARANCE REDUCTION / AXIAL DISPLACEMENT

Nominal dimensions of bearing bore		Radial clearance before mounting and clearance group						Reduction of radial clearance		Displacement on taper 1 : 12				Displacement on taper 1 : 30				Check value for minimum radial clearance after mounting				
																					normal	
above	to	min	max	min	max	min	max	min	max	min	max	min	max	min	max	min	max	min	max	normal	C3	C4
mm		mm		mm		mm		mm		mm		mm		mm		mm		mm		mm		
30	40	0,035	0,05	0,05	0,065	0,065	0,085	0,02	0,025	0,35	0,4	0,35	0,45							0,015	0,025	0,04
40	50	0,045	0,06	0,06	0,08	0,8	0,1	0,025	0,03	0,4	0,45	0,45	0,5							0,02	0,03	0,05
50	65	0,055	0,075	0,075	0,095	0,095	0,12	0,03	0,04	0,45	0,6	0,5	0,7							0,025	0,035	0,055
65	80	0,07	0,095	0,095	0,12	0,12	0,15	0,04	0,05	0,6	0,75	0,7	0,85							0,025	0,04	0,07
80	100	0,08	0,11	0,11	0,14	0,14	0,18	0,045	0,06	0,7	0,9	0,75	1			1,7	2,2	1,8	2,4	0,035	0,05	0,08
100	120	0,1	0,135	0,135	0,17	0,17	0,22	0,05	0,07	0,7	1,1	0,8	1,2	1,9	2,7	2	2,8			0,05	0,065	0,1
120	140	0,12	0,16	0,16	0,2	0,2	0,26	0,065	0,09	1,1	1,4	1,2	1,5	2,7	3,5	2,8	3,6			0,055	0,08	0,11
140	160	0,13	0,18	0,18	0,23	0,23	0,3	0,075	0,1	1,2	1,6	1,3	1,7	3	4	3,1	4,2			0,055	0,09	0,13
160	180	0,14	0,2	0,2	0,26	0,26	0,34	0,08	0,11	1,3	1,7	1,4	1,9	3,2	4,2	3,3	4,6			0,06	0,1	0,15
180	200	0,16	0,22	0,22	0,29	0,29	0,37	0,09	0,13	1,4	2	1,5	2,2	3,5	4,5	3,6	5			0,07	0,1	0,16
200	225	0,18	0,25	0,25	0,32	0,32	0,41	0,1	0,14	1,6	2,2	1,7	2,4	4	5,5	4,2	5,7			0,08	0,12	0,18
225	250	0,2	0,27	0,27	0,35	0,35	0,45	0,11	0,15	1,7	2,4	1,8	2,6	4,2	6	4,6	6,2			0,09	0,13	0,2
250	280	0,22	0,3	0,3	0,39	0,39	0,49	0,12	0,17	1,9	2,6	2	2,9	4,7	6,7	4,8	6,9			0,1	0,14	0,22
280	315	0,24	0,33	0,33	0,43	0,43	0,54	0,13	0,19	2	3	2,2	3,2	5	7,5	5,2	7,7			0,11	0,15	0,24
315	355	0,27	0,36	0,36	0,47	0,47	0,59	0,15	0,21	2,4	3,4	2,6	3,6	6	8,2	6,2	8,4			0,12	0,17	0,26
355	400	0,3	0,4	0,4	0,52	0,52	0,65	0,17	0,23	2,6	3,6	2,9	3,9	6,5	9	6,8	9,2			0,13	0,19	0,29
400	450	0,33	0,44	0,44	0,57	0,57	0,72	0,2	0,26	3,1	4,1	3,4	4,4	7,7	10	8	10,4			0,13	0,2	0,31
450	500	0,37	0,49	0,49	0,63	0,63	0,79	0,21	0,28	3,3	4,4	3,6	4,8	8,2	11	8,4	11,2			0,16	0,23	0,35
500	560	0,41	0,54	0,54	0,68	0,68	0,87	0,24	0,32	3,7	5	4,1	5,4	9,2	12,5	9,6	12,8			0,17	0,25	0,36
560	630	0,46	0,6	0,6	0,76	0,76	0,98	0,26	0,35	4	5,4	4,4	5,9	10	13,5	10,4	14			0,2	0,29	0,41
630	710	0,51	0,67	0,67	0,85	0,85	1,09	0,3	0,4	4,6	6,2	5,1	6,8	11,5	15,5	12	16			0,21	0,31	0,45
710	800	0,57	0,75	0,75	0,96	0,96	1,22	0,34	0,45	5,3	7	5,8	7,6	13,3	17,5	13,6	18			0,23	0,35	0,51
800	900	0,64	0,84	0,84	1,07	1,07	1,37	0,37	0,5	5,7	7,8	6,3	8,5	14,3	19,5	14,8	20			0,27	0,39	0,57
900	1000	0,71	0,93	0,93	1,19	1,19	1,52	0,41	0,55	6,3	8,5	7	9,4	15,8	21	16,4	22			0,3	0,43	0,64
1000	1120	0,78	1,02	1,02	1,3	1,3	1,65	0,45	0,6	6,8	9	7,6	10,2	17	23	18	24			0,32	0,48	0,7
1120	1250	0,86	1,12	1,12	1,42	1,42	1,8	0,49	0,65	7,4	9,8	8,3	11	18,5	25	19,6	26			0,34	0,54	0,77

Push the rolling bearing onto the taper bearing seat and manually screw the hydraulic nut onto the thread of the shaft or sleeve until it is in full contact with the bearing. The hydraulic nut is in the starting position. Connect the hydraulic pump to the hydraulic nut and push the rolling bearing into its mounted position by means of hydraulic pressure. After the correct axial displacement has been achieved, the hydraulic pressure should be released allowing the piston to return. The internal clearance should then be checked with feeler gauges.

9. SELECTION TABLE FOR HYDRAULIC NUT

9.1. FOR DISMOUNTING / MOUNTING WITH WITHDRAWAL SLEEVE

Size	HMV.. EBF Thread Hydraulic Nut	Shaft-Ø mm	Bearing Bore mm	WITHDRAWAL SLEEVE																			
10	M50x1,5	40	45	AH2309	AH309																		
11	M55x2	45	50	AHX2310	AHX310																		
12	M60x2	45	50	AH2310	AH310																		
12	M60x2	50	55	AHX2311	AHX311																		
13	M65x2	50	55	AH2311	AH311																		
13	M65x2	55	60	AHX2312	AHX312																		
14	M70x2	55	60	AH2312	AH312																		
14	M70x2	60	65	AH2313G	AH313G																		
15	M75x2	60	65	AH2313	AH313																		
15	M75x2	65	70	AHX2314G	AH314G																		
16	M80x2	65	70	AHX2314	AH314																		
16	M80x2	70	75	AHX2315G	AH315G																		
17	M85x2	65	70	AH2314																			
17	M85x2	70	75	AHX2315	AH315																		
18	M90x2	70	75	AH2315																			
18	M90x2	75	80	AHX2316	AH316																		
19	M95x2	75	80	AH2316																			
19	M95x2	80	85	AHX2317	AHX317																		
20	M100x2	80	85	AH2317	AH317																		
20	M100x2	85	90	AHX2318	AHX318	AHX3218																	
21	M105x2	85	90	AH2318	AH318																		
21	M105x2	90	95	AHX2319	AHX319																		
22	M110x2	90	95	AH2319	AH319																		
22	M110x2	95	100	AHX2320	AHX320	AHX3120	AHX3220																
23	M115x2	95	100	AH320																			
23	M115x2	105	110	AH24122																			
24	M120x2	95	100	AH2320																			
24	M120x2	105	110	AHX2322G	AHX3122	AHX3222G																	
25	M125x2	100	110	AH3122																			
25	M125x2	105	110	AHX2322	AHX3222																		
25	M125x2	115	120	AH24024																			
26	M130x2	100	110	AH2322	AH322																		
26	M130x2	110	120	AH3024																			
26	M130x2	115	120	AHX2324G	AH24124	AHX3024	AHX3124	AHX3224G															
27	M135x2	115	120	AHX2324	AHX3224																		
27	M135x2	125	130	AH24026																			
28	M140x2	110	120	AH2324	AH3124																		
28	M140x2	120	130	AH3026																			
28	M140x2	125	130	AHX2326G	AH24126	AHX3026	AHX3126	AHX3226G															
29	M145x2	125	130	AHX2326	AHX3226																		
29	M145x2	135	140	AH24028																			
30	M150x2	120	130	AH2326	AH3126																		
30	M150x2	130	140	AH3028																			

Operating instructions

NTN-SNR HYDRAULIC NUT HMV..EBF

Size	HMV.. EBF Thread Hydraulic Nut	Shaft-Ø mm	Bearing Bore mm	WITHDRAWAL SLEEVE																
30	M150x2	135	140	AHX2328G	AH24128	AHX3028	AHX3128	AHX3228G												
31	M155x3	135	140	AHX2328	AHX3228															
31	M155x3	145	150	AH24030																
32	M160x3	130	140	AH2328	AH3128															
32	M160x3	140	150	AH3030																
32	M160x3	145	150	AHX2330G	AH24130	AHX3030	AHX3130G	AHX3230G												
33	M165x3	145	150	AHX2330	AHX3130	AHX3230														
34	M170x3	140	150	AH2330	AH3130															
34	M170x3	150	160	AH2332G	AH24032	AH24132	AH3032	AH3132G	AH3232G											
36	M180x3	150	160	AH2332	AH3132	AH3232														
36	M180x3	160	170	AH2334G	AH24034	AH24134	AH3034	AH3134G	AH3234G											
38	M190x3	160	170	AH2334	AH3134	AH3234														
38	M190x3	170	180	AH2236G	AH2336G	AHX2336G	AH24036	AH24136	AH3036	AH3136G	AH3236G									
40	M200x3	170	180	AH2236	AH2336	AH3136	AH3236													
40	M200x3	180	190	AH2238G	AH2338G	AH24038	AH24138	AH3038G	AH3138G	AH3238G										
41	Tr205x4	180	190	AH3038																
42	Tr210x4	180	190	AH2238	AH2338	AH3138	AH3238													
42	Tr210x4	190	200	AH24040	AH24140	AH3040G														
43	Tr215x4	190	200	AH3040																
44	Tr220x4	190	200	AH2240	AH2340	AH3140	AH3240													
46	Tr230x4	200	220	AOH24044	AOH24144	AH3044G	AOH3044G													
47	Tr235x4	200	220	AH3044	AOH3044															
48	Tr240x4	200	220	AH2244	AOH2244	AH2344	AOH2344	AH3144	AOH3144											
50	Tr250x4	220	240	AOH24048																
52	Tr260x4	220	240	AH2248	AOH2248	AH2348	AOH2348	AOH24148	AH3048	AOH3048	AH3148	AOH3148								
54	Tr270x4	240	260	AOH24052																
56	Tr280x4	240	260	AH2252G	AOH2252G	AH2352G	AOH2352G	AOH24052G	AOH24152	AH3052	AOH3052	AH3152G	AOH3152G							
58	Tr290x4	240	260	AH2252	AOH2252	AH2352	AOH2352	AH3152	AOH3152											
58	Tr290x4	260	280	AOH24056																
60	Tr300x4	260	280	AH2256G	AOH2256G	AH2356G	AOH2356G	AOH24056G	AOH24156	AH3056	AOH3056	AH3156G	AOH3156G							
62	Tr310x5	260	280	AH2256	AOH2256	AH2356	AOH2356	AH3156	AOH3156											
62	Tr310x5	280	300	AOH24060																
64	Tr320x5	280	300	AH2260G	AOH2260G	AOH24060G	AOH24160	AH3060	AOH3060	AH3160G	AOH3160G	AH3260G	AOH3260G							
66	Tr330x5	280	300	AH2260	AOH2260	AH3160	AOH3160	AH3260	AOH3260											
66	Tr330x5	300	320	AOH24064																
68	Tr340x5	300	320	AH2264G	AOH2264G	AOH24064G	AOH24164	AH3064G	AOH3064G	AH3164G	AOH3164G	AH3264G	AOH3264G							
69	Tr345x5	300	320	AH3064	AOH3064															
70	Tr350x5	300	320	AH2264	AOH2264	AH3164	AOH3164	AH3264	AOH3264											
72	Tr360x5	320	340	AOH24068	AOH24168	AH3068G	AOH3068G	AH3168G	AOH3168G	AH3268G	AOH3268G									
73	Tr365x5	320	340	AH3068	AOH3068															
74	Tr370x5	320	340	AH3168	AOH3168	AH3268	AOH3268													
76	Tr380x5	340	360	AOH24072	AOH24172	AH3072G	AOH3072G	AH3172G	AOH3172G	AH3272G	AOH3272G									
77	Tr385x5	340	360	AH3072	AOH3072															

9.2. FOR DISMOUNTING / MOUNTING WITH ADAPTER SLEEVE

Size	HMV.. EBF Thread Hydraulic Nut	Soft-Ø mm	Bearing Bore mm	ADAPTER SLEEVE																	
				[H200]	[H300]	[H2300]	[H3900]	[H3000]	[H3100]	[H3200]	[H39]	[H30]	[H31]	[H32]							
10	M50x1.5	45	50	H210	H310	H2310															
11	M55x2	50	55	H211	H311	H2311															
12	M60x2	55	60	H212	H312	H2312															
13	M65x2	60	65	H213	H313	H2313															
14	M70x2	60	70	H214	H314	H2314															
15	M75x2	65	75	H215	H315	H2315															
16	M80x2	70	80	H216	H316	H2316															
18	M90x2	80	90	H218	H318	H2318															
19	M95x2	85	95	H219	H319	H2319															
20	M100x2	90	100	H220	H320	H2320				H3120											
21	M105x2	95	105	H221	H321	H2321															
22	M110x2	100	110	H222	H322	H2322				H3122											
24	M120x2	110	120			H2324		H3024	H3124												
26	M130x2	115	130			H2326		H3026	H3126												
28	M140x2	125	140			H2328		H3028	H3128												
30	M150x2	135	150			H2330		H3030	H3130												
32	M160x3	140	160			H2332		H3032	H3132												
36	M180x3	150	170			H2334		H3034	H3134												
36	M180x3	160	180			H2336	H3936	H3036	H3136												
38	M190x3	170	190			H2338	H3938	H3038	H3138												
48	Tr240x4	220	240			H2348	H3948	H3048	H3148												
56	Tr280x4	260	280			H2356	H3956	H3056	H3156												
60	Tr300x4	280	300				H3960	H3060	H3160	H3260											
64	Tr320x5	300	320				H3964	H3064	H3164	H3264											
72	Tr360x5	340	360				H3972	H3072	H3172	H3272											
76	Tr380x5	360	380				H3976	H3076	H3176	H3276											
80	Tr400x5	380	400				H3980	H3080	H3180	H3280											
84	Tr420x5	400	420				H3984	H3084	H3184	H3284											
88	Tr440x5	410	440				H3988	H3088	H3188	H3288											
92	Tr460x5	430	460				H3992	H3092	H3192	H3292											
96	Tr480x5	450	480				H3996	H3096	H3196	H3296											
100	Tr500x5	470	500								H39/500	H30/500	H31/500	H32/500							
106	Tr530x6	500	530								H39/530	H30/530	H31/530	H32/530							
112	Tr560x6	530	560								H39/560	H30/560	H31/560	H32/560							
120	Tr600x6	560	600								H39/600	H30/600	H31/600	H32/600							
126	Tr630x6	600	630								H39/630	H30/630	H31/630	H32/630							
134	Tr670x6	630	670								H39/670	H30/670	H31/670	H32/670							
150	Tr750x7	710	750								H39/750	H30/750	H31/750	H32/750							
160	Tr800x7	750	800								H39/800	H30/800	H31/800	H32/800							
170	Tr850x7	800	850									H30/850	H31/850								
180	Tr900x7	850	900									H30/900	H31/900								
190	Tr950x8	900	950									H30/950	H31/950								
200	Tr1000x8	950	1000									H30/1000	H31/1000								

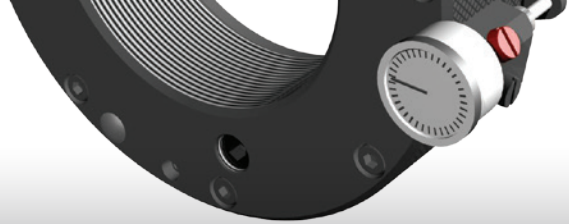

HYDRAULIC NUT

HMV..EBF



DOC.I_HMV...EBF_MANUAL_ARG1.GBa - Non contractual document - NTN-SNR Copyright International 02/2017 Printed in France - Photos : Pedro Studio Photo

