



TIMKEN
Where You Turn

Industrial Bearing Maintenance Manual

 **WARNING**

Failure to observe the following warnings could create a risk of serious injury.

Proper maintenance and handling practices are critical.
Always follow installation instructions and maintain proper lubrication.

Never spin a bearing with compressed air.
The rolling elements may be forcefully expelled.

 **CAUTION**

Failure to observe the following cautions could create a risk of serious injury.

Do not attempt to disassemble unitized bearings.

Remove oil or rust inhibitor from parts before heating to avoid fire or fumes.

If a hammer and bar are used for installation or removal of a part, use a mild steel bar (e.g. 1010 or 1020 grade). Mild steel bars are less likely to cause release of high speed fragments from the hammer, bar or the bearing.

NOTE

This manual is not intended to substitute for the specific recommendations of your equipment supplier.

Every reasonable effort has been made to ensure the accuracy of the information contained in this catalog, but no liability is accepted for errors, omissions or for any other reason.

INDEX

A	<i>TIMKEN - WHERE YOU TURN</i>	5
B	<i>GENERAL BEARING HANDLING AND INSPECTION</i>	9
C	<i>INTERNAL CLEARANCES</i>	19
D	<i>SHAFT AND HOUSING REQUIREMENTS</i>	31
E	<i>SHAFT AND HOUSING TOLERANCES ABMA STANDARD 7</i>	37
F	<i>TAPERED ROLLER BEARINGS</i>	55
G	<i>SPHERICAL ROLLER BEARINGS</i>	89
H	<i>CYLINDRICAL ROLLER BEARINGS</i>	101
I	<i>THRUST BEARINGS</i>	109
J	<i>BALL BEARINGS</i>	117
K	<i>MAINTENANCE TOOLS</i>	143
L	<i>LUBRICATION AND SEALS</i>	147



TIMKEN - WHERE YOU TURN

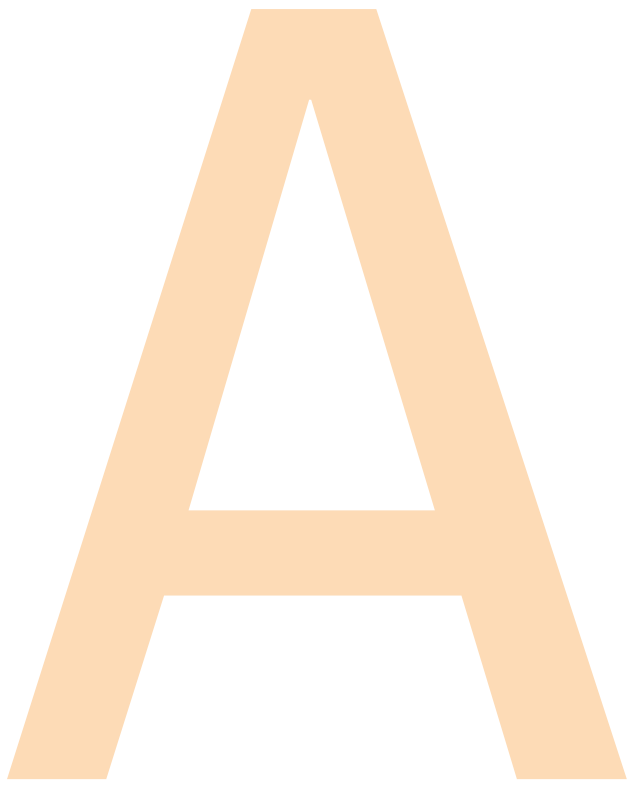

A TIMKEN - WHERE YOU TURN

A

TIMKEN - WHERE YOU TURN

A

TIMKEN - WHERE YOU TURN

Maintenance professionals around the world turn to Timken to help improve the performance and extend the life of their equipment. The information in this manual will help you follow proper industrial maintenance practices to get the most out of your Timken products and the equipment in which they operate. You will find practical information describing how to install, adjust, lubricate and maintain all of the primary types of anti-friction bearings. We have also included additional information on maintenance tools and proper lubrication.

ENGINEERING EXPERTISE

Timken has more than a century of experience developing bearings and related products that reduce friction, improve efficiency and minimize customer maintenance. Our advancements in bearing design, quality and materials create a customer advantage we call "power density." This means we are increasing bearing load-carrying capability, enabling a smaller bearing to carry the same load for the same predicted life as a previously larger one. Power density gives equipment designers greater flexibility and leads to lower total system cost.

CUSTOMER SERVICE AND SUPPORT

Practices such as bearing mounting, adjustment and proper lubrication are very specific to an application. While we are not able to encompass every practice for every application in this manual, additional Timken publications and resources are available to assist with specialized tasks for a wide range of applications.

In addition, our Timken sales representatives are available to help you address unique bearing-related application problems. Backed by a global team of experts that include metallurgists, lubrication specialists, scientists, service engineers and customer service representatives, they comprise an unmatched technical resource for our customers.

A COMPLETE LINE OF FRICTION MANAGEMENT PRODUCTS AND SERVICES

Our friction management knowledge is being applied to a broader array of products and services than ever before. We have a total system approach to our engineering philosophy and our product and service offering, which impacts uptime, maintenance costs and your bottom line. Turn to us today for one of the world's most complete friction management offerings, including:

- Condition Monitoring
- Lubrication
- Maintenance Tools
- Remanufacture and Repair
- Seals
- Training

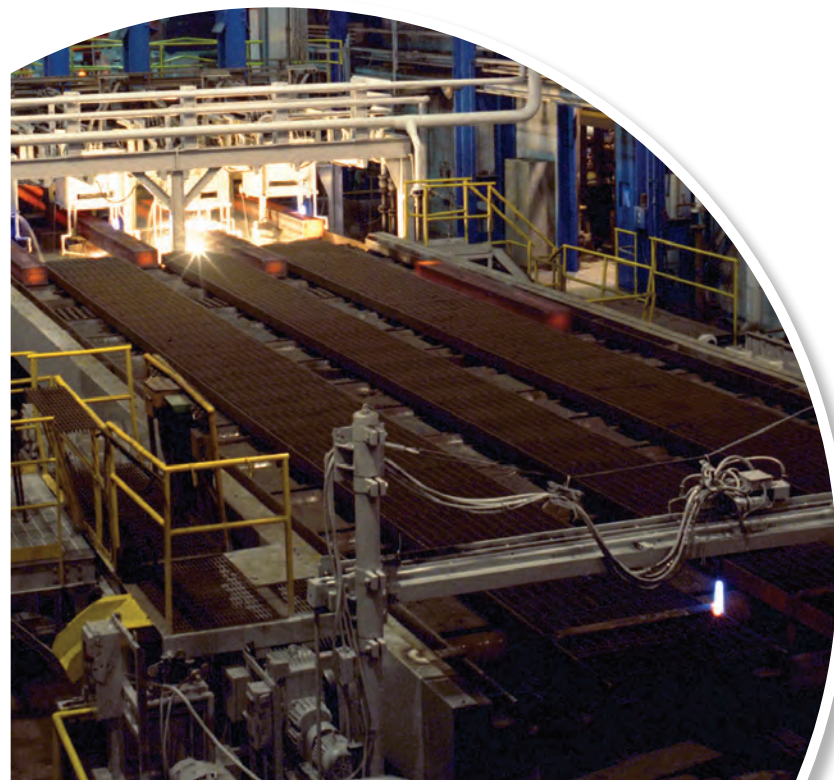



GENERAL BEARING HANDLING

B

B GENERAL BEARING HANDLING AND INSPECTION

General Bearing Handling And Inspection.....	11
Bearing Storage	11
Removing Bearings From Equipment.....	12
Damaged Bearings	14
Installation	14
Lubrication	17

AND INSPECTION

B

GENERAL BEARING HANDLING AND INSPECTION

B

GENERAL BEARING HANDLING AND INSPECTION

Bearings are a vital component in major industrial equipment. Bearing problems can result in costly downtime, equipment damage and breakdowns. In addition, large industrial bearings represent a significant capital investment.

To attain reliable operation with high equipment performance and the lowest possible maintenance costs, it is essential to follow proper handling practices. This includes bearing storage, removal, cleaning, inspection and installation.

The useful life of any bearing depends to a great extent on the care and maintenance it receives. This is especially true in industrial applications, where operating conditions tend to be harsh, loads are heavy, and contamination from dirt and scale are common.

Details about specific handling and inspection processes for different types of bearings are included in those sections of this manual. This section addresses general processes and practices that apply to all anti-friction bearing designs.

BEARING STORAGE

Bearings with special anti-corrosion coatings are available, but most bearings are not manufactured from corrosion resistant materials. When handling and storing bearings, care must be taken to ensure that they will not rust or corrode. Even a small amount of moisture or chemical left on an unprotected bearing by a glove or hand can result in a small etched area, which may initiate bearing fatigue.

New and remanufactured Timken bearings are shipped with a protective coating, are typically covered in a protective paper or other wrapping, and are shipped in a carton or crate. When receiving a new or remanufactured bearing, do not remove it from its packaging until ready to install in the application.

Do not store bearings directly on concrete floors, where water can condense and collect on the bearing. Store the bearings on a pallet or shelf, in an area where the bearings will not be subjected to high humidity or sudden and severe temperature changes that may result in condensation forming.

Always put oiled paper or, if not available, plastic sheets between rollers and cup races of tapered roller bearings.



B

REMOVING BEARINGS FROM EQUIPMENT

Each type of bearing design has a unique removal process. Regardless of the bearing type, the bearing must be removed with extreme care. If done incorrectly, you can damage the bearings, shafts or housings, requiring expensive repairs.

For smaller bearings, there are a variety of pullers available to assist with bearing removal (Fig. 1). Information concerning special pullers or other removal devices can be obtained by contacting your Timken representative.

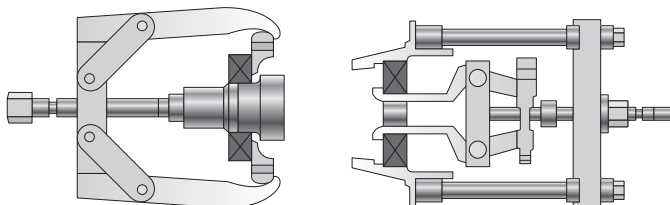

Fig. 1. Pullers for bearing removal.

For bearings installed with a tight or press fit, or that have become locked in place on a shaft and cannot be removed with a mechanical puller, the inner ring of the bearing can be heated to ease removal. Heat lamps or other heating devices can be used. If a torch is used, it will change the properties of the bearing steel and the bearing must be discarded.

WARNING Failure to observe the following warnings could create a risk of serious bodily harm.

Tensile stresses can be very high in tightly fitted bearing components. Attempting to remove such components by cutting the cone (inner race) may result in a sudden shattering of the component causing fragments of metal to be forcefully expelled. Always use properly guarded presses or bearing pullers to remove bearings from shafts, and always use suitable personal protective equipment, including safety glasses.

Lifting large bearings

Large bearings can be lifted and moved using a variety of slings, hooks, chains and mechanical devices. Some large bearings are manufactured with tapped holes in the face of inner rings or outer rings. Eyebolts or other points of attachment can be inserted in these lifting holes (Fig. 2).

Many large bearings have threaded lifting holes in the cage ring that can be used to lift the inner ring assembly.



Fig. 2. Eyebolts can be inserted into lifting holes.

CAUTION Failure to observe the following cautions could create a risk of injury.

If the bearing is to be reused or returned for repair, do not use heat from a torch. Extreme heat from a torch can alter the bearing hardness and metallurgical structure, resulting in irreparable damage.

A clean, heavy duty nylon sling provides one of the best means of handling large bearing components because it eliminates the possibility of burring or scratching.

Regardless of what method is used to lift the bearings, use care to avoid damaging any of the bearing surfaces. Be especially cautious when lifting or moving bearings that are equipped with a cage. The cage is typically the most deformable component of the bearing and is more susceptible to damage.

Cleaning

After removing a bearing from a piece of equipment, thoroughly clean it to remove all scale, water, lubricant, debris and any other contaminants. Bearings must be cleaned thoroughly to allow for proper bearing inspection.

Smaller bearings can be cleaned in a wash tank that circulates a cleaning solution such as kerosene, mineral spirits or a commercial solvent through the bearing (Fig. 3). Use the cleaning solution to remove all lubricant and contamination, making sure that the internal rolling elements are completely clean.



Fig. 3. Smaller bearings can be cleaned in a wash tank.

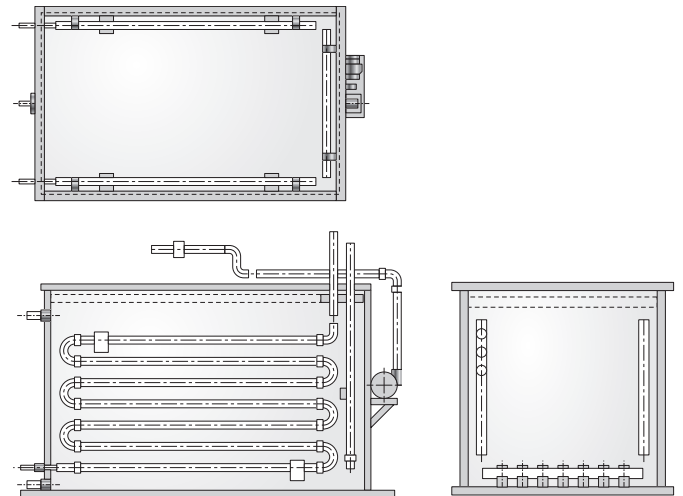

Fig. 4. Tanks are heated with electric coils and a pump is used to agitate the cleaning solution.

⚠ WARNING Failure to observe the following warnings could create a risk of serious bodily harm.

Proper maintenance and handling practices are critical. Failure to follow installation instructions and to maintain proper lubrication can result in equipment failure.

Never spin a bearing with compressed air. The rolling elements may be forcefully expelled.

Alkali cleaners, such as trisodium phosphate (TSP) mixed two or three ounces per gallon of hot water, may also be used. Hot cleaning solutions are often used as a final cleaning or rinse after the initial cleaning.

For large bearings, or to clean large numbers of bearings, special cleaning equipment such as a large tank containing appropriate cleaning solution is required. Tanks are typically heated with electrical coils, and a pump is used to agitate the cleaning solution (Fig. 4). Final cleaning is done by suspending the bearing and using a hose to flush away any contamination.

To reduce bearing contamination from other sources, all parts of the housing, shaft and gears should also be thoroughly cleaned. After the bearing has been cleaned, it can be dried with compressed air, taking care not to let the bearing spin.

After cleaning, the bearing should be carefully inspected for damage and wear. If the bearing is not going to be returned to service immediately, it should be covered with a coating of light oil to protect against rust and corrosion.

Inspection

When a piece of equipment is taken out of service for routine inspection or maintenance, take the opportunity to also inspect and measure the bearings to ensure that they are still within tolerance specifications for the application. In some applications, the expected bearing life may be the limiting factor in the equipment maintenance schedule.

The schedule for equipment tear downs for bearing inspection will vary depending on operating conditions. Consult your equipment maker for the appropriate inspection schedule.

Between equipment tear downs where full bearing inspections are conducted, you should conduct routine inspections to ensure that bearings are operating normally and have proper lubrication. To reduce the need for these inspections, and to more closely monitor bearing and equipment health, Timken condition monitoring systems are available that sense the vibration and temperature in bearings.

The inspection area must be clean and free from dirt and debris to avoid contaminating the bearing. Even a small piece of debris that enters a bearing can create a point of high stress that could lead to spalling and early fatigue.

B

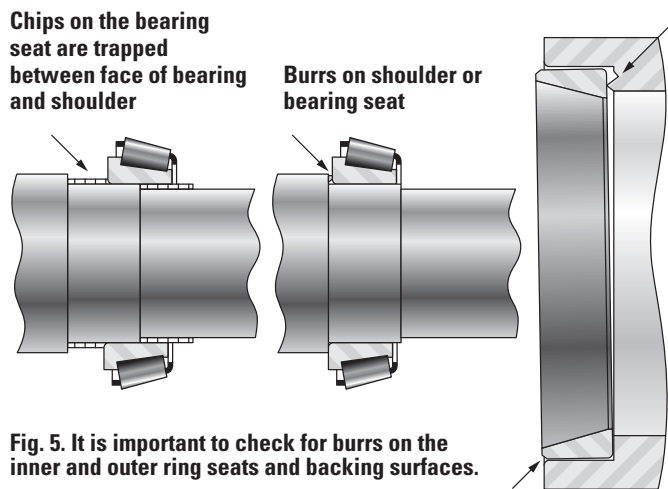

Fig. 5. It is important to check for burrs on the inner and outer ring seats and backing surfaces.

In addition to examining the bearing, a full inspection should include the housing and shaft. Check for burrs or metal chips on the inner and outer ring seats and backing surfaces (Fig. 5). Burrs or chips can be removed by scraping or filing the damaged surfaces.

Inspect the shaft for proper size, roundness, burrs or other damage. A 12-point check of the shaft with a micrometer is suggested (see page 33). If there is evidence of shaft or housing wear, it should be checked against original equipment manufacturer's specifications.

⚠ CAUTION *Failure to observe the following cautions could create a risk of injury.*

Do not attempt to disassemble unitized bearings.
Remove oil or rust inhibitor from parts before heating to avoid fire or fumes.

If a hammer and bar are used for installation or removal of a part, use a mild steel bar (e.g. 1010 or 1020 grade). Mild steel bars are less likely to cause release of high speed fragments from the hammer, bar or the bearing.

DAMAGED BEARINGS

Despite taking proper precautions, bearings may become damaged either through improper storage and handling or through normal wear in use. Bearings that have been damaged or are no longer within specifications may still be returned to service after repair or refurbishment. Some bearings can be refurbished more than once. Eventually all bearings will sustain sufficient wear or damage and will have to be replaced.

If a bearing is damaged or worn beyond repair sooner than expected, do not discard it. The nature of the damage can provide

valuable clues that can help analyze and identify possible causes, leading to corrective actions that will help ensure longer bearing life in the replacement bearing.

There are several Timken resources available to assist you in analyzing bearing damage, including online resources at timken.com and publications with photos representing common types of bearing damage. Contact your Timken representative for more information.

Bearing repair

Small areas of damage on bearing races, and on the contact surface of the rolling elements, can sometimes be repaired by grinding out the loose metal. Any raised or rough areas should be smoothed flat with grinding and polishing tools.

Light rust or corrosion should be removed with emery paper (240 – 320 # grit). As much of the damage should be removed as possible to prevent it from contaminating the bearing when it is returned to service.

For more complex bearing repairs, Timken offers remanufacture and repair services.

INSTALLATION

Do not remove the bearing from its packaging until you are ready to mount it. The packaging provides protection from contamination.

When installing a new bearing, do not remove the lubricant or preservative applied by the manufacturer. The preservatives used on almost all bearings are fully compatible with commonly used oils and other lubricants. Leaving it in place will protect the bearing from fingerprints and corrosion.

Bearings should be installed in a clean environment, free from dust, debris, moisture and other contaminants. When installing a bearing in the field, make an effort to ensure a clean work area. Use protective screens around the work area, and provide a clean resting surface for the bearing and other components until they can be installed.

Before beginning the installation, plan your work. Be certain that you have the correct replacement bearing and necessary additional components. Also determine what tools will be required, including adjustment tools if appropriate, and have them on hand. Finally, if the bearing needs to be lubricated as part of the installation process, have the appropriate lubricants and tools available. Planning your work will enable you to perform the installation more quickly with few delays, shortening the amount of time the bearing is out of the equipment and exposed to contamination and possible handling damage.



Fig. 6. Bearings can be heated in a pan or metal container filled with oil.

Thoroughly clean all machine components near where the bearing will be installed, giving special attention to the mounting surfaces and housings. Housings should be cleaned, including blowing out the oil holes. If the equipment has blind holes where air is ineffective, use a magnetic rod to remove metal chips that might have become lodged there during machining or maintenance.

Shaft surfaces that will support and contact the bearing must be clean and free from nicks or burrs. Shaft shoulders and spacer rings contacting the bearing should be square with the shaft axis. The shaft fillet must be small enough to clear the radius of the bearing.

Do not install bearings in a damaged or worn housing, or on a damaged or worn shaft. Inner and outer ring seat damage should be repaired by using properly fitted sleeves. Shafts can be built up by metal spray and machined to the correct size. If there is not a press fit on the shaft, a weld overlay and re-grind process is recommended to bring the shaft back to specification.

Heating bearings

In applications that require a tight fit of the inner ring on the shaft, it can be easier to install the bearing if it is first heated to expand slightly. For applications that require a tight fit of the outer ring in a housing, it may also be possible to heat the housing to expand it, allowing the bearing to install more easily.

Small bearings can be heated using several methods. They can be heated in a pan or metal container filled with oil (Fig. 6). A screen or platform should be used to keep the bearing from resting on the bottom of the pan where heat is applied.



Fig. 7. Induction heater.

A heat lamp can also be used to heat rings, and the temperature regulated by adjusting the distance from the light to the ring.

The fastest method of safely heating bearings is an induction heater (Fig. 7). Induction heaters work very quickly. Take care to avoid heating the bearing to temperatures higher than 120°C (250°F).

For larger bearings, you may need to use an oil bath to heat the bearing (Fig. 8). Maximum temperature of the oil bath should not exceed 120°C (250°F). The bearing should be positioned in the center of the tank, and allowed to heat long enough to fully expand. Do not allow the bearing to come in direct contact with the heat source.

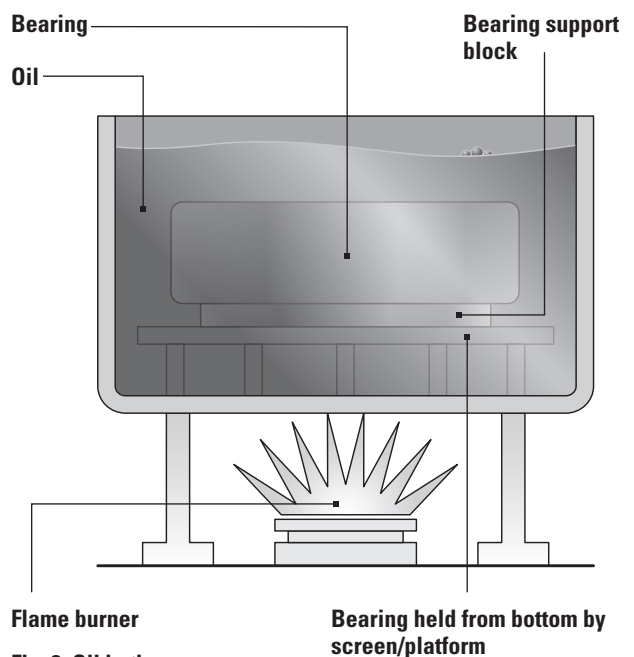

Fig. 8. Oil bath.

CAUTION Failure to observe the following cautions could create a risk of injury.

If the bearing is to be reused or returned for repair, do not use heat from a torch.

Extreme heat from a torch can alter the bearing hardness and metallurgical structure, resulting in irreparable damage.

Keep the bearings away from any localized high-heat source that may raise the bearing temperature too high, resulting in race hardness reduction.

When heating bearings, be sure that they have enough time to fully heat. Bearings typically require 20 to 30 minutes of soak time per inch of inner-ring cross section to fully heat in an oil tank.

While the bearing is still warm, remove it from the heater or tank and place it on the shaft. Slide the bearing up the shaft until it squarely contacts the shaft shoulder. Then install the locknut/washer or clamping plate to prevent the bearing from backing off the shoulder while cooling. As the bearing cools, the locknut or clamping plate should be tightened.

Thermal growth of components can be calculated using the formula:

$$d \times \Delta T \times \alpha = \text{Thermal Growth}$$

Where:

d = bearing bore diameter

ΔT = maximum bearing temperature after heating minus ambient temperature

α = coefficient of linear expansion: $11 \times 10^{-6}/^{\circ}\text{C}$ ($6.1 \times 10^{-6}/^{\circ}\text{F}$) for ferrous metal shaft and housing materials

Sample calculation

Example:

For a bearing with a 3-1/2 in. bore heated from an ambient temperature of 70° F to 200° F, the thermal growth of the bearing bore diameter can be calculated as follows:

$$\text{Thermal Growth} = 3.500'' \times (200^{\circ} - 70^{\circ}) \times 6.1 \times 10^{-6} = 0.0028 \text{ in.}$$

For a bearing with a 90 mm bore heated from an ambient temperature of 21° C to 93° C:

$$\text{Thermal Growth} = 90 \text{ mm} \times (93^{\circ} - 21^{\circ}) \times 11 \times 10^{-6} = 0.071 \text{ mm}$$

TEMPERATURE GUIDELINES FOR HEATING OR COOLING ROLLING ELEMENT BEARINGS FOR INSTALLATION

These maximum and minimum temperatures, as well as maximum time-at-temperature limits, have been established to prevent metallurgical transformation of steel components, and potential, detrimental physical changes in seals or non-metallic components. During the manufacturing process, bearing rings and rolling elements are heat treated to define the strength, hardness and dimensional stability for proper operation. Heating or cooling bearings or bearing components beyond these limits may affect performance.

These suggestions are merely guidelines and, as new data is developed, the values as shown may change. These guidelines do not cover all Timken® products.

NOTE: Always use protective safety equipment and clothing when handling parts that have been heated or cooled.

Never heat a bearing with a torch, as localized heating will irreparably damage bearing components.

Never rapidly heat or freeze a bearing or bearing component.

Only use approved equipment, methods and controls to achieve desired temperature.

Always follow OEM instructions to ensure bearings and rings are properly positioned after heating or cooling.

Heating

Standard class bearings or rings (with metallic cages and without seals):

- Include Class 2, 4, 7, K, N, ABEC-1 and ABEC-3
- 93°C (200°F) - 24 Hours
- 121°C (250°F) - 8 Hours

Precision bearings or rings (with non-metallic cages and polymer or elastomer seals):

- Special considerations may apply for phenolic cages or special fluorocarbon lip seals.
- Include Class 3, 0, 00, 000, C, B, A, AA, ABEC 5 and 7

Precision and superprecision class bearings and rings (any)

- 66°C (150°F) - 24 Hours

Cooling (Freezing)

Freezing standard class bearings and rings

- 54°C (-65°F) - 1 Hour

Freezing precision class outer rings or cups

- -29°C (-20°F) - 2 Hours

Note: This temperature can be obtained by commercial freezer/ refrigeration equipment.

Cone bore temperature reading in degrees

Cone Bore	Thermometer Temperature Reading in Degrees		
	65° C 150° F	90° C 200° F	120° C 250° F
mm in.	mm in.	mm in.	mm in.
25.4 1	0.012 0.0005	0.020 0.0008	0.027 0.0011
50.8 2	0.025 0.0010	0.040 0.0016	0.055 0.0022
76.2 3	0.036 0.0014	0.058 0.0023	0.081 0.0032
101.6 4	0.048 0.0019	0.078 0.0031	0.109 0.0043
127 5	0.061 0.0024	0.099 0.0039	0.137 0.0054
152.4 6	0.073 0.0029	0.119 0.0047	0.165 0.0065
177.8 7	0.086 0.0034	0.139 0.0055	0.193 0.0076
203.2 8	0.096 0.0038	0.157 0.0062	0.218 0.0086
228.6 9	0.109 0.0043	0.177 0.0070	0.246 0.0097
254 10	0.121 0.0048	0.198 0.0078	0.274 0.0108
279.4 11	0.134 0.0053	0.218 0.0086	0.302 0.0119
304.8 12	0.147 0.0058	0.238 0.0094	0.330 0.013
330 13	0.157 0.0062	0.256 0.0101	0.355 0.014
355.6 14	0.170 0.0067	0.276 0.0109	0.383 0.0151
381 15	0.182 0.0072	0.297 0.0117	0.411 0.0162
406.4 16	0.195 0.0077	0.317 0.0125	0.439 0.0173
431.8 17	0.208 0.0082	0.337 0.0133	0.467 0.0184
457.2 18	0.218 0.0086	0.355 0.014	0.492 0.0194

Cone Bore	Thermometer Temperature Reading in Degrees		
	65° C 150° F	90° C 200° F	120° C 250° F
mm in.	mm in.	mm in.	mm in.
482.6 19	0.231 0.0091	0.375 0.0148	0.520 0.0205
508 20	0.243 0.0096	0.396 0.0156	0.548 0.0216
533.4 21	0.256 0.0101	0.416 0.0164	0.576 0.0227
558.8 22	0.269 0.0106	0.436 0.0172	0.604 0.0238
584.2 23	0.279 0.011	0.454 0.0179	0.629 0.0248
609.6 24	0.292 0.0115	0.475 0.0187	0.657 0.0259
635 25	0.304 0.012	0.495 0.0195	0.685 0.027
660.4 26	0.317 0.0125	0.515 0.0203	0.713 0.0281
685.8 27	0.330 0.013	0.535 0.0211	0.741 0.0292
711.2 28	0.340 0.0134	0.553 0.0218	0.767 0.0302
736.6 29	0.353 0.0139	0.574 0.0226	0.795 0.0313
762 30	0.365 0.0144	0.594 0.0234	0.823 0.0324
787.4 31	0.378 0.0149	0.614 0.0242	0.85 0.0335
812.8 32	0.391 0.0154	0.635 0.025	0.878 0.0346
838.2 33	0.401 0.0158	0.652 0.0257	0.904 0.0356
863.6 34	0.414 0.0163	0.673 0.0265	0.932 0.0367
889 35	0.426 0.0168	0.693 0.0273	0.960 0.0378
914.4 36	0.439 0.0173	0.713 0.0281	0.988 0.0389

Pressing on bearings

Smaller bearings may be pressed onto the shaft or into a housing with an arbor press and mounting tube. Between the press ram and the bearing, use a tube of soft steel with an inside diameter slightly larger than the shaft. The outside diameter of the tube should not exceed the maximum shoulder height for the bearings. The tube should be square at both ends, thoroughly clean inside and out, and long enough to clear the end of the shaft after the bearing is mounted.

- Inspect the shaft and housing for proper size, roundness, burrs or other damage. A 12-point check of the shaft with a micrometer is suggested (see page 33).
- Coat the shaft with light machine oil or assembly paste to reduce the force needed to press the bearing on the shaft.
- Use a tube or pipe with an inner diameter (I.D.) that is slightly larger than the outer diameter (O.D.) of the shaft. The O.D. of the tube or pipe should be small enough that it does not contact the rolling elements or cage of the bearing.
- Position the tube on the inner ring and apply steady pressure with sufficient force to smoothly press the ring into place, and firmly against the shoulder or backing surface (Fig. 9).

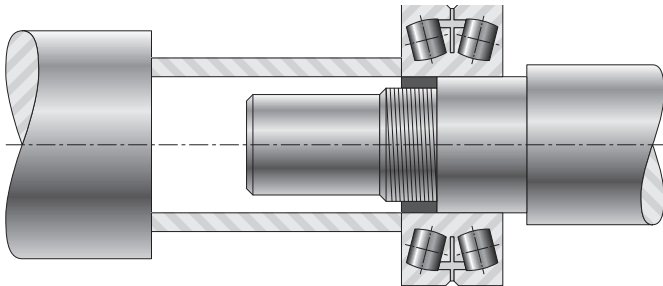

Fig. 9. Positioning the tube on the inner ring.

Never attempt to make a press fit on a shaft by applying pressure to the outer ring of an assembled bearing. However, because they have a separable outer ring, the outer ring of tapered roller bearings can be pressed into a housing. See page 61.

For specific information regarding bearing installation in your equipment, contact the equipment manufacturer.

Adjusting bearing clearance

The space between the rolling elements and the races of an anti-friction bearing is known as the bearing clearance, referred to in tapered roller bearings as the lateral, lateral clearance or end play. In other types of anti-friction bearings such as spherical, cylindrical, or ball bearings, the radial internal clearance or RIC, is specified. Clearance is desirable in applications where allowance must be provided for thermal growth of components, to accommodate for slight misalignment or other application requirements.

Bearings may also have zero clearance, with the contact surfaces of the rolling elements brought into contact with the races in line-to-line contact.

Finally, bearings may have the rolling elements and races brought into contact with a defined initial force, a condition known as preload. This enables precise control over the internal geometry of the mating parts, and is desirable where runout must be held within critical limits, such as high precision applications.

Bearings with separable races, such as tapered roller bearings, allow the clearance (preload) to be “adjusted” to meet application requirements. Other types of bearings are manufactured with a known clearance or preload, but the clearance can be slightly reduced through an interference fit on the inner or outer race.

For information about adjusting various types of bearings, see the section of this manual for each bearing design.

LUBRICATION

See the Lubrication Section of this manual beginning on page 155.

INTERNAL CLEARANCES



C INTERNAL CLEARANCES

Tapered Roller Bearings.....	21
Radial Ball Bearings.....	22
Spherical Roller Bearings.....	25
Cylindrical Roller Bearings.....	27

INTERNAL CLEARANCES

c

INTERNAL CLEARANCES

TAPERED ROLLER BEARINGS

In tapered roller bearings, internal clearance is usually defined as a specific amount of either end play or preload. Establishing this clearance, or setting, at the time of assembly is an inherent advantage of tapered roller bearings. They can be set to provide optimum performance in almost any application. Fig. 10 gives an example of the relationship between fatigue life and bearing setting. Unlike some types of anti-friction bearings, tapered roller bearings do not rely strictly on housing or shaft fits to obtain a certain bearing setting. One race can be moved axially relative to the other to obtain the desired bearing setting.

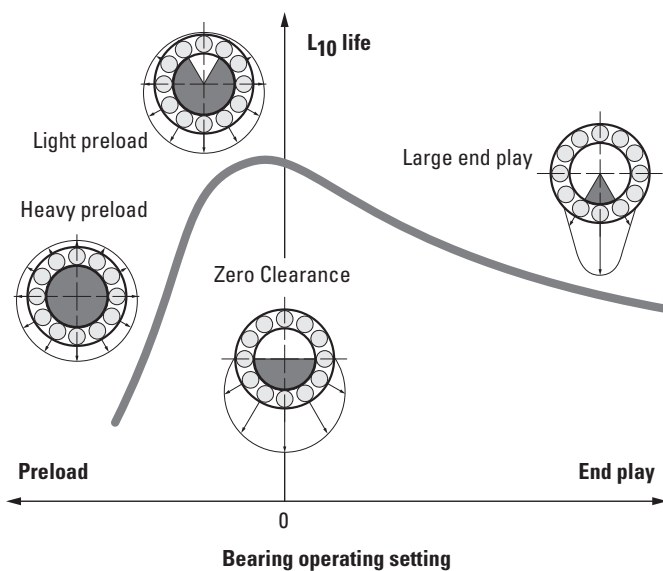

Fig. 10. Relationship between fatigue life and bearing setting.

At assembly, the conditions of bearing setting are defined as:

- End play – An axial clearance between rollers and races producing a measurable axial shaft movement when a small axial force is applied - first in one direction, then in the other, while oscillating or rotating the shaft (Fig. 11).
- Preload – An axial interference between rollers and races such that there is no measurable axial shaft movement when a small axial force is applied - in both directions, while oscillating or rotating the shaft.
- Line-to-line – A zero setting condition; the transitional point between end play and preload.

Bearing setting obtained during initial assembly and adjustment is the cold or ambient bearing setting and is established before the equipment is subjected to service.

Bearing setting during operation is known as the operating bearing setting and is a result of changes in the ambient bearing setting due to thermal expansion and deflections encountered during service.

The ambient bearing setting necessary to produce the optimum operating bearing setting varies with the application. Application experience, or testing, generally permits the determination of optimum settings. Frequently, however, the exact relationship of ambient to operating bearing setting is an unknown and an educated estimate has to be made. To determine a suggested ambient bearing setting for a specific application, consult with your Timken representative.

Generally, the ideal operating bearing setting is near zero to maximize bearing life. Most bearings are set with end play at assembly to reach the desired near zero setting at operating temperature when mounted.

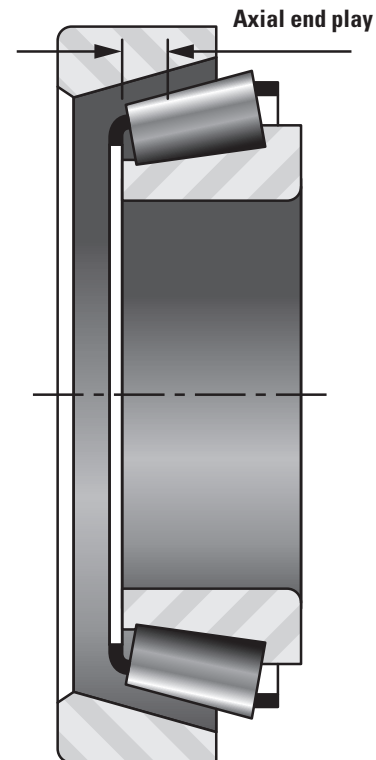

Fig. 11. Axial force is applied in both directions while rotating the shaft.

RADIAL BALL BEARINGS

In the manufacture of ball bearings, it is standard practice to assemble rings and balls with a specified internal clearance. This characteristic is necessary to absorb the effect of press fitting the bearing rings at mounting.

Internal clearances sometimes are used to compensate for thermal expansion of bearings, shafts and housings or to provide a contact angle in the bearing after mounting. Internal clearance can be measured either by gaging radially or axially.

Radial measurement is accepted as the more significant characteristic because it is more directly related to shaft and housing fits. It also is the method prescribed by the American Bearing Manufacturers Association (ABMA).

Radial internal clearance

The radial internal clearance (RIC) of a radial contact ball bearing can be defined as the average outer ring raceway diameter minus

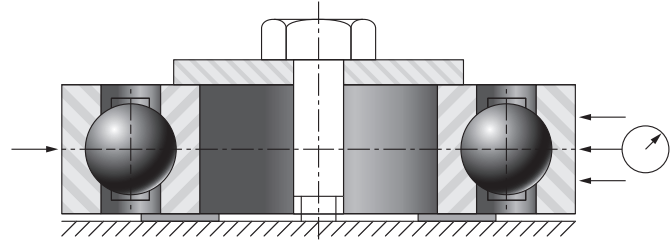

Fig. 12. RIC can be measured mechanically by moving the outer ring horizontally.

the average inner ring raceway diameter minus twice the ball diameter.

RIC can be measured mechanically by moving the outer ring horizontally as pictured in Fig. 12. The total movement of the outer ring when the balls are properly seated in the raceways determines the radial internal clearance. Several readings should be taken using different circumferential orientations of the rings in order to get a comprehensive average reading.

Limits for radial internal clearance of single-row, radial contact ball bearings under no load

(Applies to bearings of ABEC-1, ABEC-3, ABEC-5, ABEC-7, and ABEC-9 Tolerances)

Timken® Prefix (ABMA designation)		H (C2)		R (C0)		P (C3)		J (C4)		JJ (C5)	
Basic Bore Diameter mm		Acceptance Limits		Acceptance Limits		Acceptance Limits		Acceptance Limits		Acceptance Limits	
over	incl.	Max.	Min.	Max.	Min.	Max.	Min.	Max.	Min.	Max.	Min.
		mm in.	mm in.	mm in.	mm in.	mm in.	mm in.	mm in.	mm in.	mm in.	mm in.
2.5	10	0.007 0.0003	0.000 0.0000	0.013 0.0005	0.002 0.0001	0.023 0.0009	0.008 0.0003	0.029 0.0011	0.014 0.0006	0.037 0.0015	0.020 0.0008
10	18	0.009 0.00035	0.000 0.0000	0.018 0.0007	0.003 0.0001	0.025 0.001	0.011 0.0004	0.033 0.0013	0.018 0.0007	0.045 0.0018	0.025 0.0010
18	24	0.010 0.0004	0.000 0.0000	0.020 0.0008	0.005 0.0002	0.028 0.0011	0.013 0.0005	0.036 0.0014	0.020 0.0008	0.048 0.0019	0.028 0.0011
24	30	0.011 0.00045	0.001 0.0001	0.020 0.0008	0.005 0.0002	0.028 0.0011	0.013 0.0005	0.041 0.0016	0.023 0.0009	0.053 0.0021	0.030 0.0012
30	40	0.011 0.00045	0.001 0.0001	0.020 0.0008	0.006 0.0002	0.033 0.0013	0.015 0.0006	0.046 0.0018	0.028 0.0011	0.064 0.0025	0.040 0.0016
40	50	0.011 0.00045	0.001 0.0001	0.023 0.0009	0.006 0.00025	0.036 0.0014	0.018 0.0007	0.051 0.0020	0.030 0.0012	0.073 0.0029	0.045 0.0018
50	65	0.015 0.0006	0.001 0.0001	0.028 0.0011	0.008 0.00035	0.043 0.0017	0.023 0.0009	0.061 0.0024	0.038 0.0015	0.090 0.0035	0.055 0.0022
65	80	0.015 0.0006	0.001 0.0001	0.030 0.0012	0.010 0.0004	0.051 0.0020	0.025 0.0010	0.071 0.0028	0.046 0.0018	0.105 0.0041	0.065 0.0026

Continued on next page.

Timken® Prefix (ABMA designation)		H (C2)		R (C0)		P (C3)		J (C4)		JJ (C5)	
Basic Bore Diameter mm		Acceptance Limits		Acceptance Limits		Acceptance Limits		Acceptance Limits		Acceptance Limits	
		Max.	Min.	Max.	Min.	Max.	Min.	Max.	Min.	Max.	Min.
over	incl.	mm in.	mm in.	mm in.	mm in.	mm in.	mm in.	mm in.	mm in.	mm in.	mm in.
80	100	0.018 0.0007	0.001 0.0001	0.036 0.0014	0.012 0.00045	0.058 0.0023	0.030 0.0012	0.084 0.0033	0.053 0.0021	0.120 0.0047	0.075 0.0030
100	120	0.020 0.0008	0.002 0.0001	0.041 0.0016	0.015 0.0006	0.066 0.0026	0.036 0.0014	0.097 0.0038	0.061 0.0024	0.140 0.0055	0.090 0.0035
120	140	0.023 0.0009	0.002 0.0001	0.048 0.0019	0.018 0.0007	0.081 0.0032	0.041 0.0016	0.114 0.0045	0.071 0.0028	0.160 0.0063	0.105 0.0041
140	160	0.023 0.0009	0.002 0.0001	0.053 0.0021	0.018 0.0007	0.091 0.0036	0.046 0.0018	0.130 0.0051	0.081 0.0032	0.180 0.0071	0.120 0.0047
160	180	0.025 0.0010	0.002 0.0001	0.061 0.0024	0.020 0.0008	0.102 0.0040	0.053 0.0021	0.147 0.0058	0.091 0.0036	0.200 0.0079	0.135 0.0053
180	200	0.030 0.0012	0.002 0.0001	0.071 0.0028	0.025 0.0010	0.117 0.0046	0.063 0.0025	0.163 0.0064	0.107 0.0042	0.230 0.0091	0.150 0.0059
200	240	0.036 0.0014	0.003 0.0001	0.081 0.0032	0.030 0.0012	0.137 0.0054	0.074 0.0029	0.193 0.0076	0.127 0.0050	0.267 0.0105	0.183 0.0072
240	280	0.041 0.0016	0.003 0.0001	0.097 0.0038	0.033 0.0013	0.157 0.0062	0.086 0.0034	0.224 0.0088	0.147 0.0058	0.310 0.0122	0.213 0.0084
280	320	0.048 0.0019	0.005 0.0002	0.114 0.0045	0.041 0.0016	0.180 0.0071	0.104 0.0041	0.257 0.0101	0.170 0.0067	0.353 0.0139	0.246 0.0097
320	370	0.053 0.0021	0.005 0.0002	0.127 0.0050	0.046 0.0018	0.208 0.0082	0.117 0.0046	0.295 0.0116	0.198 0.0078	0.409 0.0161	0.284 0.0112
370	430	0.064 0.0025	0.008 0.0003	0.147 0.0058	0.056 0.0022	0.241 0.0095	0.137 0.0054	0.340 0.0134	0.231 0.0091	0.475 0.0187	0.330 0.013
430	500	0.074 0.0029	0.010 0.0004	0.170 0.0067	0.066 0.0026	0.279 0.0110	0.160 0.0063	0.396 0.0156	0.269 0.0106	0.551 0.0217	0.386 0.0152
500	570	0.081 0.0032	0.010 0.0004	0.193 0.0076	0.074 0.0029	0.318 0.0125	0.183 0.0072	0.450 0.0177	0.307 0.0121	0.630 0.0248	0.439 0.0173
570	640	0.091 0.0036	0.013 0.0005	0.216 0.0085	0.085 0.0033	0.356 0.0140	0.206 0.0081	0.505 0.0199	0.345 0.0136	0.706 0.0278	0.495 0.0195
640	710	0.114 0.0045	0.020 0.0008	0.239 0.0094	0.107 0.0042	0.394 0.0155	0.229 0.0090	0.564 0.0222	0.384 0.0151	0.780 0.0307	0.554 0.0218
710	800	0.140 0.0055	0.020 0.0008	0.269 0.0106	0.130 0.0051	0.445 0.0175	0.259 0.0102	0.630 0.0248	0.434 0.0171	0.879 0.0346	0.620 0.0244
800	1060	0.211 0.0083	0.028 0.0011	0.353 0.0139	0.201 0.0079	0.587 0.0231	0.345 0.0136	0.833 0.0328	0.577 0.0227	1.148 0.0452	0.823 0.0324

■ : Standard fits for Timken radial ball bearings. P(C3) for bearing O.D. greater than 52 mm.



INTERNAL CLEARANCES

Timken Bearing Number Prefix	ISO/ABMA Symbol	Description
H	C2	Snug fit; slight internal clearance; sometimes used to achieve a minimum of radial or axial play in an assembly. Example: H204K.
R	C0	Medium fit; internal clearance generally satisfactory with recommended shaft and housing fits. Example: RMM204K.
P	C3	Loose fit; considerable internal clearance required for applications involving press fits on both inner and outer rings, extra interference fits, or temperature differentials. Example: P204K.
J	C4	Extra loose fit; large amount of internal clearance for applications involving large interference fits or temperature differentials. Example: J204K.
JJ	C5	Extra-extra loose fit; extra large amount of internal clearance for applications with large temperature differential and interference fits on both rings.

Table 1. Radial clearance designations correlate with ISO/ABMA symbols.

End Play

End play is an alternate method of measuring internal clearance and is rarely used except for certain special applications. End play is determined by mounting the bearing, as shown in Fig. 13, with one of its rings clamped to prevent axial movement. A reversing measuring load is applied to the unclamped ring so the resulting movement of that ring is parallel to the bearing axis. End play is the total movement of the unclamped ring when the load is applied first in one direction and then in the other.

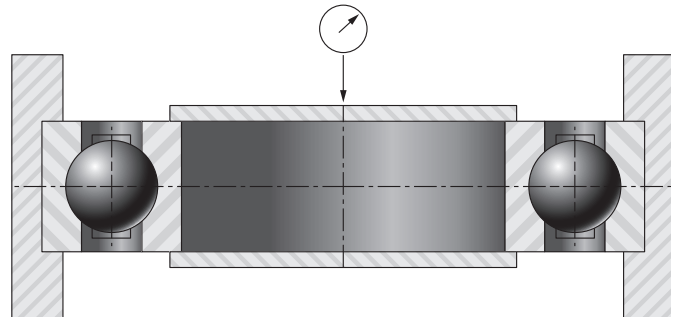

Fig. 13. End play is determined by mounting the bearing with one of its rings clamped.

SPHERICAL ROLLER BEARINGS

RIC is the radial internal clearance or radial play within a bearing. The bearing’s RIC allows a tight fit, with sufficient internal clearance after installation for normal operating conditions.

Spherical roller bearings with tapered bore (K) require a slightly greater interference fit on the shaft than a cylindrical bore bearing. The effect of this greater interference fit is a reduction of RIC. For tapered bore bearings, it is critical to select the RIC that allows for this reduction.

Example #1 - Calculating RIC Reduction Using a Spherical Roller Bearing with Tapered Bore

Given bearing number 22328K C3 (140 mm bore with a C3 clearance) is to be mounted on a tapered shaft. Using a set of feeler gauges, RIC is found to be –

$$RIC = 0.178 \text{ mm (0.007 in.)}$$

Suggested Reduction of RIC Due to Installation = 0.064 to 0.089 mm (0.0025 in. to 0.0035 in.), found in chart on page 26.

Calculate the clearance after mounting –

$$0.178 \text{ mm} - 0.077 \text{ mm} = 0.101 \text{ mm or}$$

$$0.007 \text{ in.} - 0.003 \text{ in.} = 0.004 \text{ in.}$$

NOTE: For this example, the value of 0.077 mm (0.003 in.) was obtained by taking the mid-range value of the upper and lower limits found in the table on page 26.

Therefore, the locking nut should be tightened until RIC reaches 0.101 mm (0.004 in.).

It should also be noted that the value obtained by reading the Suggested RIC after Installation directly from the table on page 97 is 0.075 mm (0.0030 in.). This differs from the value calculated in the above example. The value taken directly from the table is provided as a minimum value. It is not suggested to use a calculated value that falls below this minimum.

Several factors influence RIC reduction. Inner rings pressed onto solid steel shafts expand approximately 80 percent of the interference fit. Outer rings pressed into steel or cast iron housings reduce RIC by about 60 percent of the interference fit. For RIC reduction on hollow shafts or non-steel materials, consult a Timken representative.

Timken® brand bearings are supplied with normal RIC, unless specified otherwise. The desired RIC code must be added to the bearing number, following all other suffixes.

Minimum/maximum values for each RIC are shown in the two adjacent columns directly beneath the selected RIC. For example, the minimum values shown for C5 are also the maximum values for C4; minimum values for C4 are also the maximum values for C3; etc.

Radial internal clearance limits - radial spherical roller bearings

Bore (Nominal) mm	Cylindrical Bore						Tapered Bore						Suggested Reduction of RIC Due to Installation		Suggested RIC after installation ⁽¹⁾		
	Normal CO		C4		Normal CO		C4		C2		C3					C5	
	Min.	Max.	Min.	Max.	Min.	Max.	Min.	Max.	Min.	Max.	Min.	Max.				Min.	Max.
	Min.	Max.	Min.	Max.	Min.	Max.	Min.	Max.	Min.	Max.	Min.	Max.				Min.	Max.
Over	Incl.	mm in.		mm in.		mm in.		mm in.		mm in.		mm in.		mm in.	mm in.		
24	30	0.015 0.0006	0.025 0.0010	0.040 0.0016	0.055 0.0022	0.075 0.0030	0.095 0.0037	0.020 0.0008	0.030 0.0012	0.040 0.0016	0.055 0.0022	0.075 0.0030	0.095 0.0037	0.015 0.0006	0.020 0.0008	0.015 0.0006	
30	40	0.015 0.0006	0.030 0.0012	0.045 0.0018	0.060 0.0024	0.080 0.0031	0.100 0.0039	0.025 0.0010	0.035 0.0014	0.050 0.0020	0.065 0.0026	0.085 0.0033	0.105 0.0041	0.020 0.0008	0.025 0.0010	0.015 0.0006	
40	50	0.020 0.0008	0.035 0.0014	0.055 0.0022	0.075 0.0030	0.100 0.0039	0.125 0.0049	0.030 0.0012	0.045 0.0018	0.060 0.0024	0.080 0.0031	0.100 0.0039	0.130 0.0051	0.025 0.0010	0.030 0.0012	0.020 0.0008	
50	65	0.020 0.0008	0.040 0.0016	0.065 0.0026	0.090 0.0035	0.120 0.0047	0.150 0.0059	0.040 0.0016	0.055 0.0022	0.075 0.0030	0.095 0.0037	0.120 0.0047	0.160 0.0063	0.030 0.0012	0.038 0.0015	0.025 0.0010	
65	80	0.030 0.0012	0.050 0.0020	0.080 0.0031	0.110 0.0043	0.145 0.0057	0.180 0.0071	0.050 0.0020	0.070 0.0028	0.095 0.0037	0.120 0.0047	0.150 0.0059	0.200 0.0079	0.038 0.0015	0.051 0.0020	0.025 0.0010	
80	100	0.035 0.0014	0.060 0.0024	0.100 0.0039	0.135 0.0053	0.180 0.0071	0.225 0.0089	0.055 0.0022	0.080 0.0030	0.110 0.0043	0.140 0.0055	0.180 0.0071	0.230 0.0091	0.046 0.0018	0.064 0.0025	0.036 0.0014	

⁽¹⁾ For bearings with normal initial clearance.

Continued on next page.

INTERNAL CLEARANCES

Bore (Nominal) mm		Cylindrical Bore						Tapered Bore						Suggested Reduction of RIC Due to Installation		Suggested RIC after Installation ⁽¹⁾
		Normal CO		C4				Normal CO		C4						
		Min.	Max.	Min.	Max.			Min.	Max.	Min.	Max.					
		C2		C3		C5		C2		C3		C5				
Over	Incl.	mm in.	mm in.	mm in.	mm in.	mm in.	mm in.	mm in.	mm in.	mm in.	mm in.	mm in.	mm in.	mm in.	mm in.	
100	120	0.040 0.0016	0.075 0.0030	0.120 0.0047	0.160 0.0063	0.210 0.0083	0.260 0.0102	0.065 0.0026	0.100 0.0039	0.135 0.0053	0.170 0.0067	0.220 0.0087	0.280 0.0110	0.051 0.0020	0.071 0.0028	0.051 0.0020
120	140	0.050 0.0020	0.095 0.0037	0.145 0.0057	0.190 0.0075	0.240 0.0094	0.300 0.0118	0.080 0.0031	0.120 0.0047	0.160 0.0063	0.200 0.0079	0.260 0.0102	0.330 0.0130	0.064 0.0025	0.089 0.0035	0.056 0.0022
140	160	0.060 0.0024	0.110 0.0043	0.170 0.0067	0.220 0.0087	0.280 0.0110	0.350 0.0138	0.090 0.0035	0.130 0.0051	0.180 0.0071	0.230 0.0091	0.300 0.0118	0.380 0.0150	0.076 0.0030	0.102 0.0040	0.056 0.0022
160	180	0.065 0.0026	0.120 0.0047	0.180 0.0071	0.240 0.0094	0.310 0.0122	0.390 0.0154	0.100 0.0039	0.140 0.0055	0.200 0.0079	0.260 0.0102	0.340 0.0134	0.430 0.0169	0.076 0.0030	0.114 0.0045	0.061 0.0024
180	200	0.070 0.0028	0.130 0.0051	0.200 0.0079	0.260 0.0102	0.340 0.0134	0.430 0.0169	0.110 0.0043	0.160 0.0063	0.220 0.0087	0.290 0.0114	0.370 0.0146	0.470 0.0185	0.089 0.0035	0.127 0.0050	0.071 0.0028
200	225	0.080 0.0031	0.140 0.0055	0.220 0.0087	0.290 0.0114	0.380 0.0150	0.470 0.0185	0.120 0.0047	0.180 0.0071	0.250 0.0098	0.320 0.0126	0.410 0.0161	0.520 0.0205	0.102 0.0040	0.140 0.0055	0.076 0.0030
225	250	0.090 0.0035	0.150 0.0059	0.240 0.0094	0.320 0.0126	0.420 0.0165	0.520 0.0205	0.140 0.0055	0.200 0.0079	0.270 0.0106	0.350 0.0138	0.450 0.0177	0.570 0.0224	0.114 0.0045	0.152 0.0060	0.089 0.0035
250	280	0.100 0.0039	0.170 0.0067	0.260 0.0102	0.350 0.0138	0.460 0.0181	0.570 0.0224	0.150 0.0059	0.220 0.0087	0.300 0.0118	0.390 0.0154	0.490 0.0193	0.620 0.0244	0.114 0.0045	0.165 0.0065	0.102 0.0040
280	315	0.110 0.0043	0.190 0.0075	0.280 0.0110	0.370 0.0146	0.500 0.0197	0.630 0.0248	0.170 0.0067	0.240 0.0094	0.330 0.0130	0.430 0.0169	0.540 0.0213	0.680 0.0268	0.127 0.0050	0.178 0.0070	0.102 0.0040
315	355	0.120 0.0047	0.200 0.0079	0.310 0.0122	0.410 0.0161	0.550 0.0217	0.690 0.0272	0.190 0.0075	0.270 0.0106	0.360 0.0142	0.470 0.0185	0.590 0.0232	0.740 0.0291	0.140 0.0055	0.190 0.0075	0.114 0.0045
355	400	0.130 0.0051	0.220 0.0087	0.340 0.0134	0.450 0.0177	0.600 0.0236	0.750 0.0295	0.210 0.0083	0.300 0.0118	0.400 0.0157	0.520 0.0205	0.650 0.0256	0.820 0.0323	0.152 0.0060	0.203 0.0080	0.127 0.0050
400	450	0.140 0.0055	0.240 0.0094	0.370 0.0146	0.500 0.0197	0.660 0.0260	0.820 0.0323	0.230 0.0091	0.330 0.0130	0.440 0.0173	0.570 0.0224	0.720 0.0283	0.910 0.0358	0.165 0.0065	0.216 0.0085	0.152 0.0060
450	500	0.140 0.0055	0.260 0.0102	0.410 0.0161	0.550 0.0217	0.720 0.0283	0.900 0.0354	0.260 0.0102	0.370 0.0146	0.490 0.0193	0.630 0.0248	0.790 0.0311	1.000 0.0394	0.178 0.0070	0.229 0.0090	0.165 0.0065
500	560	0.150 0.0059	0.280 0.0110	0.440 0.0173	0.600 0.0236	0.780 0.0307	1.000 0.0394	0.290 0.0114	0.410 0.0161	0.540 0.0213	0.680 0.0268	0.870 0.0343	1.100 0.0433	0.203 0.0080	0.254 0.0100	0.178 0.0070
560	630	0.170 0.0067	0.310 0.0122	0.480 0.0189	0.650 0.0256	0.850 0.0335	1.100 0.0433	0.320 0.0126	0.460 0.0181	0.600 0.0236	0.760 0.0299	0.980 0.0386	1.230 0.0484	0.229 0.0090	0.279 0.0110	0.203 0.0080
630	710	0.190 0.0075	0.350 0.0138	0.530 0.0209	0.700 0.0276	0.920 0.0362	1.190 0.0469	0.350 0.0138	0.510 0.0201	0.670 0.0264	0.850 0.0335	1.090 0.0429	1.360 0.0535	0.254 0.0100	0.305 0.0120	0.203 0.0080
710	800	0.210 0.0083	0.390 0.0154	0.580 0.0228	0.770 0.0303	1.010 0.0398	1.300 0.0512	0.390 0.0154	0.570 0.0224	0.750 0.0295	0.960 0.0378	1.220 0.0480	1.500 0.0591	0.279 0.0110	0.356 0.0140	0.229 0.0090
800	900	0.230 0.0091	0.430 0.0169	0.650 0.0256	0.860 0.0339	1.120 0.0441	1.440 0.0567	0.440 0.0173	0.640 0.0252	0.840 0.0331	1.070 0.0421	1.370 0.0539	1.690 0.0665	0.305 0.0120	0.381 0.0150	0.252 0.0100
900	1000	0.260 0.0102	0.480 0.0189	0.710 0.0280	0.930 0.0366	1.220 0.0480	1.57 0.0618	0.490 0.0193	0.710 0.0280	0.930 0.0366	1.190 0.0469	1.520 0.0598	1.860 0.0732	0.356 0.0140	0.432 0.0170	0.279 0.0110

⁽¹⁾ For bearings with normal initial clearance.

■ : For bearings with normal initial clearance.

Min./Max. values for each RIC are shown in the two adjacent columns directly beneath the selected RIC. Each single column represents a boundary between adjacent RIC's. For example, the minimum values shown for C5 are also the maximum values for C4; minimum values for C4 are also the maximum values for C3; etc.

* Special clearances can be provided (C6, C7, etc.)

CYLINDRICAL ROLLER BEARINGS

Cylindrical roller bearings are available with RIC designations per either of the following tables: “Timken ‘R’ Clearance” or “ISO/ABMA ‘C’ Clearance.” Non-standard values are also available by special request. Standard radial internal clearance values are listed in the following tables based on bore size. The clearance

required for a given application depends on the desired operating precision, rotational speed of the bearing, and the fitting practice used. Most applications use a normal, or C0, clearance. Typically, a larger clearance reduces the operating zone of the bearing, increases the maximum roller load, and reduces the bearing’s expected life.

ISO/ABMA radial internal clearance limits

Bore mm in.		C2		C0		C3		C4		C5	
Over	Incl.	Max.	Min.	Max.	Min.	Max.	Min.	Max.	Min.	Max.	Min.
		mm in.		mm in.		mm in.		mm in.		mm in.	
0 0	10 0.3937	0.025 0.0010	0.000 0.0000	0.045 0.0018	0.020 0.0008	0.060 0.0024	0.035 0.0014	0.075 0.0030	0.050 0.0020	- -	- -
10 0.3937	24 0.9449	0.025 0.0010	0.000 0.0000	0.045 0.0018	0.020 0.0008	0.060 0.0024	0.035 0.0014	0.075 0.0030	0.050 0.0020	0.090 0.0035	0.065 0.0026
24 0.9449	30 1.1811	0.025 0.0010	0.000 0.0000	0.045 0.0018	0.020 0.0008	0.060 0.0024	0.035 0.0014	0.075 0.0030	0.050 0.0020	0.095 0.0037	0.070 0.0028
30 1.1811	40 1.5748	0.030 0.0012	0.005 0.0002	0.050 0.0020	0.025 0.0010	0.070 0.0028	0.045 0.0018	0.085 0.0033	0.060 0.0024	0.105 0.0041	0.080 0.0031
40 1.5748	50 1.9685	0.035 0.0014	0.005 0.0002	0.060 0.0024	0.030 0.0012	0.080 0.0031	0.050 0.0020	0.100 0.0039	0.070 0.0028	0.125 0.0049	0.095 0.0037
50 1.9685	65 2.5591	0.040 0.0016	0.010 0.0004	0.070 0.0028	0.040 0.0016	0.090 0.0035	0.060 0.0024	0.110 0.0043	0.080 0.0031	0.140 0.0055	0.110 0.0043
65 2.5591	80 3.1496	0.045 0.0018	0.010 0.0004	0.075 0.0030	0.040 0.0016	0.100 0.0039	0.065 0.0026	0.125 0.0049	0.090 0.0035	0.165 0.0065	0.130 0.0051
80 3.1496	100 3.9370	0.050 0.0020	0.015 0.0006	0.085 0.0033	0.050 0.0020	0.110 0.0043	0.075 0.0030	0.140 0.0055	0.105 0.0041	0.190 0.0075	0.155 0.0061
100 3.9370	120 4.7244	0.055 0.0022	0.015 0.0006	0.090 0.0035	0.050 0.0020	0.125 0.0049	0.085 0.0033	0.165 0.0065	0.125 0.0049	0.220 0.0087	0.180 0.0071
120 4.7244	140 5.5118	0.060 0.0024	0.015 0.0006	0.105 0.0041	0.060 0.0024	0.145 0.0057	0.100 0.0039	0.190 0.0075	0.145 0.0057	0.245 0.0096	0.200 0.0079
140 5.5118	160 6.2992	0.070 0.0028	0.020 0.0008	0.120 0.0047	0.070 0.0028	0.165 0.0065	0.115 0.0045	0.215 0.0085	0.165 0.0065	0.275 0.0108	0.225 0.0089
160 6.2992	180 7.0866	0.075 0.0030	0.025 0.0010	0.125 0.0049	0.075 0.0030	0.170 0.0067	0.120 0.0047	0.220 0.0087	0.170 0.0067	0.300 0.0118	0.250 0.0098

These values indicate the expected range of mounted RIC following suggested push up values. Timken suggests that customers consult with our engineers to evaluate unique applications or requirements for special operating conditions.

Continued on next page.

INTERNAL CLEARANCES

Bore mm in.		C2		C0		C3		C4		C5	
Over	Incl.	Max.	Min.	Max.	Min.	Max.	Min.	Max.	Min.	Max.	Min.
		mm in.		mm in.		mm in.		mm in.		mm in.	
180 7.0866	200 7.8740	0.090 0.0035	0.035 0.0014	0.145 0.0057	0.090 0.0035	0.195 0.0077	0.140 0.0055	0.250 0.0098	0.195 0.0077	0.330 0.0130	0.275 0.0108
200 7.8740	225 8.8583	0.105 0.0041	0.045 0.0018	0.165 0.0065	0.105 0.0041	0.220 0.0087	0.160 0.0063	0.280 0.0110	0.220 0.0087	0.365 0.0144	0.305 0.0120
225 8.8583	250 9.8425	0.110 0.0043	0.045 0.0018	0.175 0.0069	0.110 0.0043	0.235 0.0093	0.170 0.0067	0.300 0.0118	0.235 0.0093	0.395 0.0156	0.330 0.0130
250 9.8425	280 11.0236	0.125 0.0049	0.055 0.0022	0.195 0.0077	0.125 0.0049	0.260 0.0102	0.190 0.0075	0.330 0.0130	0.260 0.0102	0.440 0.0173	0.370 0.0146
280 11.0236	315 12.4016	0.130 0.0051	0.055 0.0022	0.205 0.0081	0.130 0.0051	0.275 0.0108	0.200 0.0079	0.350 0.0138	0.275 0.0108	0.485 0.0191	0.410 0.0161
315 12.4016	355 13.9764	0.145 0.0057	0.065 0.0026	0.225 0.0089	0.145 0.0057	0.305 0.0120	0.225 0.0089	0.385 0.0152	0.305 0.0120	0.535 0.0211	0.455 0.0179
355 13.9764	400 15.7480	0.190 0.0075	0.100 0.0039	0.280 0.0110	0.190 0.0075	0.370 0.0146	0.280 0.0110	0.460 0.0181	0.370 0.0146	0.600 0.0236	0.510 0.0201
400 15.7480	450 17.7165	0.210 0.0083	0.110 0.0043	0.310 0.0122	0.210 0.0083	0.410 0.0161	0.310 0.0122	0.510 0.0201	0.410 0.0161	0.665 0.0262	0.565 0.0222
450 17.7165	500 19.6850	0.220 0.0087	0.110 0.0043	0.330 0.0130	0.220 0.0087	0.440 0.0173	0.330 0.0130	0.550 0.0217	0.440 0.0173	0.735 0.0289	0.625 0.0246
500 19.6850	560 22.0472	0.240 0.00945	0.120 0.00472	0.360 0.01417	0.240 0.00945	0.480 0.0189	0.360 0.01417	0.600 0.02362	0.480 0.0189	0.810 0.03189	0.690 0.02717
560 22.0472	630 24.8031	0.260 0.01024	0.140 0.00551	0.380 0.01496	0.260 0.01024	0.500 0.01969	0.380 0.01496	0.620 0.02441	0.500 0.01969	0.900 0.03543	0.780 0.03071
630 24.8031	710 27.9528	0.285 0.01122	0.145 0.00571	0.425 0.01673	0.285 0.01122	0.565 0.02224	0.425 0.01673	0.705 0.02776	0.565 0.02224	1.005 0.03957	0.865 0.03406
710 27.9528	800 31.4961	0.310 0.0122	0.150 0.00591	0.470 0.0185	0.310 0.0122	0.630 0.0248	0.470 0.0185	0.790 0.0311	0.630 0.0248	1.135 0.04469	0.975 0.03839
800 31.4961	900 35.4331	0.350 0.01378	0.180 0.00709	0.520 0.02047	0.350 0.01378	0.690 0.02717	0.520 0.02047	0.860 0.03386	0.690 0.02717	1.265 0.0498	1.095 0.04311
900 35.4331	1000 39.3701	0.390 0.01535	0.200 0.00787	0.580 0.02283	0.390 0.01535	0.770 0.03031	0.580 0.02283	0.960 0.0378	0.770 0.03031	1.405 0.05531	1.215 0.04783

These values indicate the expected range of mounted RIC following suggested push up values. Timken suggests that customers consult with our engineers to evaluate unique applications or requirements for special operating conditions.

Min./Max. values for each RIC are shown in the two adjacent columns directly beneath the selected RIC. Each single column represents a boundary between adjacent RIC's. For example, the minimum values shown for R5 are also the maximum values for R4;

minimum values for R4 are also the maximum values for R3; etc. The desired RIC code (R1, R2, etc.) must be added to the bearing number, following all other suffixes.

Timken radial internal clearance limits

Bore (Nominal)		R2		R4			
		Min.	Max.	Min.	Max.		
		R1		R3		R5	
Over	Incl.	Min.	Max.	Min.	Max.	Min.	Max.
mm in.		mm in.		mm in.		mm in.	
80 3.1496	100 3.9370	0.013 0.0005	0.041 0.0016	0.081 0.0032	0.130 0.0051	0.196 0.0077	0.272 0.0107
100 3.9370	120 4.7244	0.013 0.0005	0.046 0.0018	0.091 0.0036	0.152 0.0060	0.226 0.0089	0.310 0.0122
120 4.7244	140 5.5118	0.023 0.0009	0.056 0.0022	0.104 0.0041	0.170 0.0067	0.256 0.0101	0.353 0.0139
140 5.5118	160 6.2992	0.025 0.0010	0.066 0.0026	0.124 0.0049	0.196 0.0077	0.284 0.0112	0.384 0.0151
160 6.2992	180 7.0866	0.028 0.0011	0.069 0.0027	0.132 0.0052	0.208 0.0082	0.300 0.0118	0.401 0.0158
180 7.0866	200 7.8740	0.036 0.0014	0.081 0.0032	0.152 0.0060	0.234 0.0092	0.330 0.0130	0.437 0.0172
200 7.8740	220 8.6614	0.041 0.0016	0.086 0.0034	0.157 0.0062	0.239 0.0094	0.335 0.0132	0.4420 0.0174
220 8.6614	260 10.2362	0.056 0.0022	0.102 0.0040	0.173 0.0068	0.254 0.0100	0.351 0.0138	0.455 0.018
260 10.2362	300 11.8110	0.061 0.0024	0.107 0.0042	0.178 0.0070	0.259 0.0102	0.356 0.0140	0.462 0.0182
300 11.8110	350 13.7795	0.081 0.0032	0.127 0.0050	0.198 0.0078	0.279 0.0110	0.376 0.0148	0.483 0.0190
350 13.7795	400 15.7480	0.107 0.0042	0.165 0.0065	0.236 0.0093	0.318 0.0125	0.414 0.0163	0.521 0.0205
400 15.7480	450 17.7165	0.14 0.0055	0.203 0.0080	0.279 0.0110	0.361 0.0142	0.457 0.0180	0.564 0.0222
450 17.7165	500 19.6850	0.152 0.0060	0.216 0.0085	0.292 0.0115	0.381 0.0150	0.508 0.0200	0.645 0.0254
500 19.6850	560 22.0472	0.165 0.0065	0.229 0.0090	0.305 0.0120	0.406 0.0160	0.533 0.0210	0.671 0.0264
560 22.0472	630 24.8031	0.178 0.0070	0.254 0.0100	0.356 0.0140	0.483 0.0190	0.610 0.0240	0.747 0.0294
630 24.8031	710 27.9528	0.190 0.0075	0.279 0.0110	0.381 0.0150	0.508 0.0200	0.635 0.0250	0.772 0.0304
710 27.9528	800 31.4961	0.216 0.0085	0.330 0.0130	0.457 0.0180	0.584 0.0230	0.711 0.0280	0.848 0.0334





SHAFT AND HOUSING REQUIREMENTS

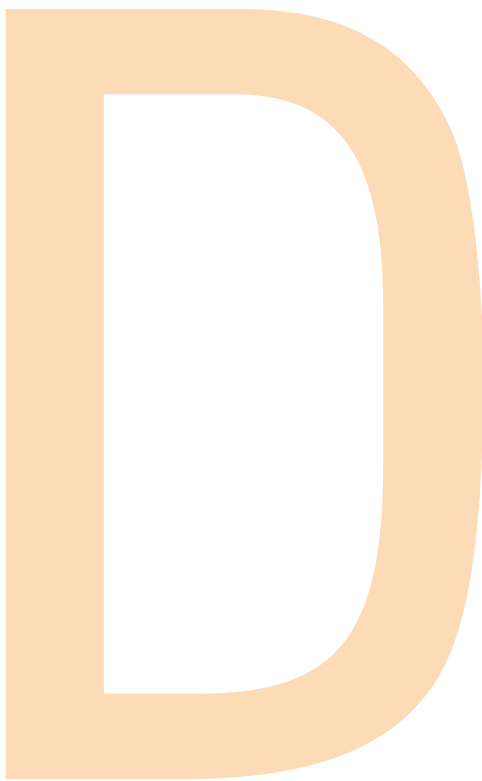

D SHAFT AND HOUSING REQUIREMENTS

Shaft And Housing Requirements	33
The 12-Point Measurement Procedure	33



SHAFT AND HOUSING REQUIREMENTS

D

SHAFT AND HOUSING REQUIREMENTS

The bearings are only one element in mechanical systems designed to precisely support shafts in machines and equipment. The life of even the highest quality bearings will be dramatically shortened unless the other supporting elements (e.g. journals, housings and shafts) are machined to the appropriate dimensions and are within specifications for squareness, surface finish and other parameters.

A 12-point inspection is suggested to properly inspect a bearing journal or housing bore.

Verify the geometry of mating components by comparing the inspection measurements to the suggested mating component tolerance limits. Shaft and housing limits are selected using specific application criteria. Tables of these limits may be found in the bearing-specific section of this manual. Diameter size, roundness and taper form can be confirmed after the 12 measurements are recorded.

THE 12-POINT MEASUREMENT PROCEDURE

Use two-point gauges that are accurate to 0.002 mm or 0.0001 inches. Gages with accuracy to 1/10 of the units being inspected are suggested, providing resolution to 0.0002 mm or 0.00001 inches.

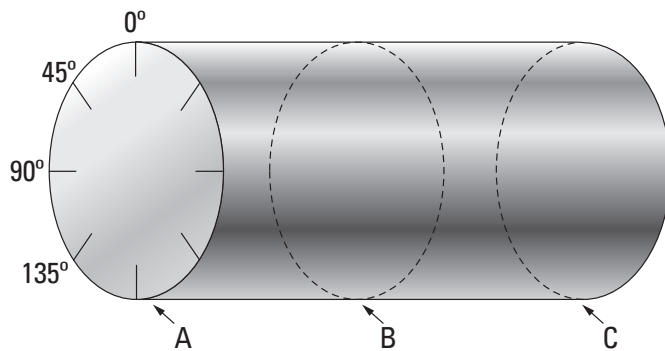

Fig. 14. Gauge the shaft in four positions.

	0°	45°	90°	135°	AVERAGES	AVERAGES
PLANE A					A =	
PLANE B					B =	
PLANE C					C =	

Fig. 15. Record measurements using a chart.

Gauge the shaft in four positions, beginning at 0° and then working around the shaft 45°, 90°, and 135° (Fig. 14). Repeat these measurements at three different planes along the shaft, measuring at the mating surfaces where the shaft will be in direct contact with the bearing. The three planes should be evenly spaced across the contact area. The outboard measurements should be approximately 5 mm (0.2 in.) from the ends of the shaft.

Record the measurements on a chart (Fig. 15), being sure to record each measurement for the respective plane and angle. Then calculate the average diameter at each plane.

Diameter (Size) Evaluation

Compare the average diameter measurement of planes A, B and C to the suggested tolerance limits. Each average diameter should be within the suggested limits. The mating component diameter is out of specification if any average is over or under the suggested limits.

Roundness (Form) Evaluation

Also compare the individual measurements at each angle of measurement (e.g. compare each of the three measurements taken at 45°) to the suggested limit. If any measurement is larger or smaller than one half the suggested limit, an out-of-round condition exists.



SHAFT AND HOUSING REQUIREMENTS

12-point measurement worksheet

Application: _____ Machine: _____

Comments: _____

Shaft Tolerances Required: _____ Max: _____ Min: _____ 1/2 Limit: _____

Housing Tolerances Required: _____ Max: _____ Min: _____ 1/2 Limit: _____

Measurements (gages accurate to 0.002 mm/0.0001 in. minimum are recommended)

	0°	45°	90°	135°	AVERAGES	AVERAGES
PLANE A					A =	
PLANE B					B =	
PLANE C					C =	

Diameter size evaluation: Compare the average diameter measurement taken at each of planes A, B and C to the suggested tolerance limits. The mating component diameter is out of specification if any average is over or under the suggested limits.

Roundness form evaluation: Compare the individual measurements at each angle of measurement to one other. An out-of-round condition exists if any of the measurements are more than one half of the suggested limit.

Taper (form) evaluation

Taper is determined by taking the difference between the plane averages as follows:

AVERAGE A =	AVERAGE B =	AVERAGE A =
- AVERAGE B =	- AVERAGE C =	- AVERAGE C =
DIFFERENCE =	DIFFERENCE =	DIFFERENCE =

Excessive taper exists if any of the differences exceeds the specified tolerance range by more than one half.

Surface finish reference

Common surface finishes for shafts are:

- ≤ 2 in. diameter = 32 R_a finish maximum
- > 2 in. diameter = 65 R_a finish maximum for straight shafts
- 50 R_a finish maximum for tapered shafts

Common surface finishes required for housings are:

- Stationary outer ring required to float = 65 R_a maximum
- Stationary outer ring not required to float = 125 R_a maximum

Example

A 22324YMW33W800C4 bearing is specified for shaker screens. This application requires a P6 housing tolerance limit. The P6 housing diameters are 10.2331 in./10.2343 inches.

The housing plane average diameters are verified to be between the limits of 10.2331 in. and 10.2343 inches. Roundness and taper inspections require one half of the permissible tolerance limits be calculated. Thus:

$$\begin{array}{r} 10.2343 \text{ in.} \\ - 10.2331 \text{ in.} \\ \hline .0012 \text{ in.} \quad \text{maximum limit} \\ \text{and} \\ \frac{.0012 \text{ in.}}{2} = .0006 \text{ in.} \end{array}$$

Roundness is verified by comparing the differences of the four measurements of a given plane. No difference should exceed 0.0006 inches.

Straightness is verified by comparing the differences of the three averages. No difference should exceed 0.0006 inches.

Other factors to consider

The performance and life of anti-friction rolling element bearings can be greatly enhanced by following these practices and specifications:

- Working environment must be clean during installation.
- Accepted care, handling techniques, tools and fixtures must be used during the removal and installation of bearings.
- Mating component geometry and materials should meet industry standards. These standards are available in the Timken Products Catalog.



SHAFT AND HOUSING TOLERANCES



E SHAFT AND HOUSING TOLERANCES ABMA STANDARD 7

Radial Ball, Spherical, Cylindrical And Metric Series Tapered Roller Bearings.....	39
Shaft Tolerances.....	40
Housing Tolerances.....	46

ABMA STANDARD 7



SHAFT AND HOUSING TOLERANCES ABMA STANDARD 7

E

SHAFT AND HOUSING TOLERANCES ABMA STANDARD 7

RADIAL BALL, SPHERICAL AND CYLINDRICAL ROLLER BEARINGS

Fig. 16 is a graphical representation of shaft and housing fit selection for these bearings conforming to ANSI/ABMA Standard 7. The bars designated by g6, h6, etc. represent shaft/housing diameter and tolerance ranges to achieve various loose and interference fits required for various load and ring rotation conditions.

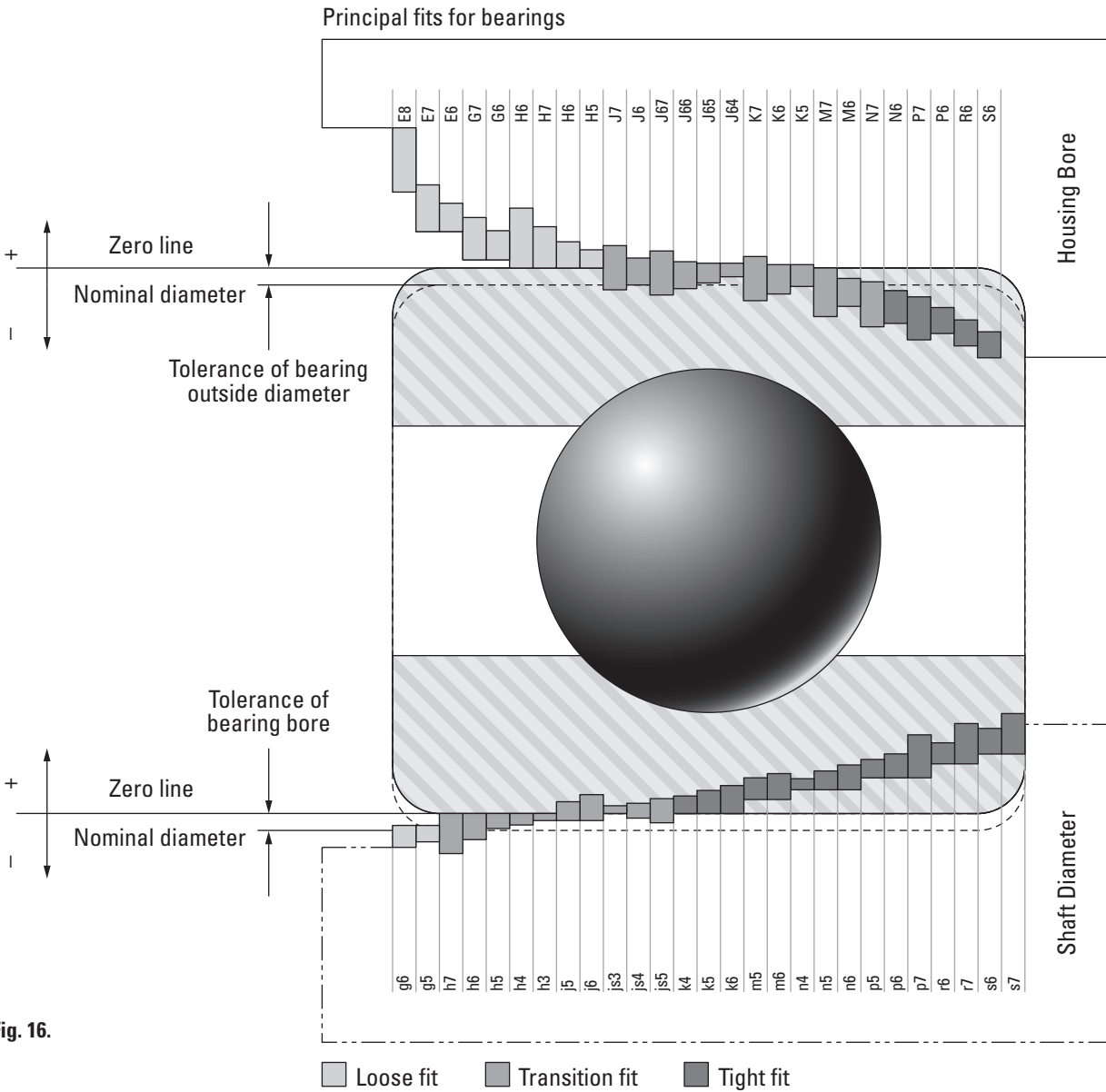

Fig. 16.



SHAFT AND HOUSING TOLERANCES ABMA STANDARD 7

Shaft tolerances: radial ball, spherical and cylindrical roller bearings

Bearing Bore		g6				h6			h5			j5		
Nominal (Max.)		Tolerance 0.000 mm 0.0000 in. To	Shaft Diameter		Fit	Shaft Diameter		Fit	Shaft Diameter		Fit	Shaft Diameter		Fit
Over	Incl.		Max.	Min.		Max.	Min.		Max.	Min.		Max.	Min.	
mm		mm in.	mm in.		mm in.			mm in.			mm in.			
3	6	-0.008 -0.0003	-0.004 -0.0002	-0.012 -0.0005	0.012L 0.004T 0.0005L 0.0001T	0.000 0.0000	-0.008 -0.0003	0.008L 0.008T 0.0003L 0.0003T	0.000 0.0000	-0.005 -0.0002	0.005L 0.008T 0.0002L 0.0003T	+0.003 +0.0001	-0.002 -0.0001	0.002L 0.011T 0.0001L 0.0004T
6	10	-0.008 -0.0003	-0.005 -0.0002	-0.014 -0.0006	0.014L 0.003T 0.0006L 0.0001T	0.000 0.0000	-0.009 -0.0004	0.009L 0.008T 0.0004L 0.0003T	0.000 0.0000	-0.006 -0.0002	0.006L 0.008T 0.0002L 0.0003T	+0.002 +0.0004	-0.002 -0.0001	0.002L 0.012T 0.0001L 0.0005T
10	18	-0.008 -0.0003	-0.006 -0.0002	-0.017 -0.0007	0.017L 0.002T 0.0007L 0.0001T	0.000 0.0000	-0.011 -0.0004	0.011L 0.008T 0.0004L 0.0003T	0.000 0.0000	-0.008 -0.0003	0.008L 0.008T 0.0003L 0.0003T	+0.005 +0.0002	-0.003 -0.0001	0.003L 0.013T 0.0001L 0.0005T
18	30	-0.010 -0.0004	-0.007 -0.0003	-0.020 -0.0008	0.020L 0.003T 0.0008L 0.0001T	0.000 0.0000	-0.013 -0.0005	0.013L 0.010T 0.0005L 0.0004T				+0.005 +0.0002	-0.004 -0.0002	0.004L 0.015T 0.0002L 0.0006T
30	50	-0.012 -0.00045	-0.009 -0.0004	-0.025 -0.0010	0.025L 0.003T 0.0010L 0.00005T	0.000 0.0000	-0.016 -0.0006	0.016L 0.012T 0.0006L 0.00045T				+0.006 +0.0002	-0.005 -0.0002	0.005L 0.018T 0.0002L 0.00065T
50	80	-0.015 -0.0006	-0.010 -0.0004	-0.029 -0.0011	0.029L 0.005T 0.0011L 0.0002T	0.000 0.0000	-0.019 -0.0007	0.019L 0.015T 0.0007L 0.0006T				+0.006 +0.0002	-0.007 -0.0003	0.007L 0.021T 0.0003L 0.0008T
80	120	-0.020 -0.0008	-0.012 -0.0005	-0.034 -0.0013	0.034L 0.008T 0.0013L 0.0003T	0.000 0.0000	-0.022 -0.0009	0.022L 0.020T 0.0009L 0.0008T				+0.006 +0.0002	-0.009 -0.0004	0.009L 0.026T 0.0004L 0.0010T
120	180	-0.025 -0.0010	-0.014 -0.0006	-0.039 -0.0015	0.039L 0.011T 0.0015L 0.0004T	0.000 0.0000	-0.025 -0.0010	0.025L 0.025T 0.0010L 0.0010T				+0.007 +0.0003	-0.011 -0.0004	0.011L 0.032T 0.0004L 0.0013T
180	200	-0.030 -0.0012	-0.015 -0.0006	-0.044 -0.0017	0.044L 0.015T 0.0017L 0.0006T	0.000 0.0000	-0.029 -0.0011	0.029L 0.030T 0.0011L 0.0012T				+0.007 +0.0003	-0.013 -0.0005	0.013L 0.037T 0.0005L 0.0015T
200	225	-0.030 -0.0012	-0.015 -0.0006	-0.044 -0.0017	0.044L 0.015T 0.0017L 0.0006T	0.000 0.0000	-0.029 -0.0011	0.029L 0.030T 0.0011L 0.0012T				+0.007 +0.0003	-0.013 -0.0005	0.013L 0.037T 0.0005L 0.0015T
225	250	-0.030 -0.0012	-0.015 -0.0006	-0.044 -0.0017	0.044L 0.015T 0.0017L 0.0006T	0.000 0.0000	-0.029 -0.0011	0.029L 0.030T 0.0011L 0.0012T				+0.007 +0.0003	-0.013 -0.0005	0.013L 0.037T 0.0005L 0.0015T
250	280	-0.035 -0.0014	-0.017 -0.0007	-0.049 -0.0019	0.049L 0.018T 0.0019L 0.0007T	0.000 0.0000	-0.032 -0.0013	0.032L 0.035T 0.0013L 0.0014T				+0.007 +0.0003	-0.016 -0.0006	0.016L 0.042T 0.0006L 0.0017T
280	315	-0.035 -0.0014	-0.017 -0.0007	-0.049 -0.0019	0.049L 0.018T 0.0019L 0.0007T	0.000 0.0000	-0.032 -0.0013	0.032L 0.035T 0.0013L 0.0014T				+0.007 +0.0003	-0.016 -0.0006	0.016L 0.042T 0.0006L 0.0017T

NOTE: Tolerance and shaft diameters are shown in the table as variances from nominal bearing bore.

See pages 125-133 for actual shaft and housing diameters for normal loading of ABEC-1 and ABEC-3 radial ball bearings and 7000WN Series angular contact ball bearings.

See appropriate pages for particular operating conditions of radial ball (page 134), spherical (pages 92-93) and cylindrical roller bearings (page 106).

SHAFT AND HOUSING TOLERANCES ABMA STANDARD 7

j6			k5			k6			m5		
Shaft Diameter		Fit	Shaft Diameter		Fit	Shaft Diameter		Fit	Shaft Diameter		Fit
Max.	Min.		Max.	Min.		Max.	Min.		Max.	Min.	
mm in.			mm in.			mm in.			mm in.		
+0.006 +0.0002	-0.002 -0.0001	0.002L 0.014T 0.0001L 0.0005T	+0.006 +0.0002	+0.001 +0.0000	0.001T 0.014T 0.0000T 0.0005T				+0.009 +0.0004	+0.004 +0.0002	0.004T 0.017T 0.0002T 0.0007T
+0.007 +0.0003	-0.002 -0.0001	0.002L 0.015T 0.0001L 0.0006T	+0.007 +0.0003	+0.001 +0.0000	0.001T 0.015T 0.0000T 0.0006T				+0.012 +0.0005	+0.006 +0.0002	0.006T 0.020T 0.0002T 0.0008T
+0.008 +0.0003	-0.003 -0.0001	0.003L 0.016T 0.0001L 0.0006T	+0.009 +0.0004	+0.001 +0.0000	0.001T 0.017T 0.0000T 0.0007T				+0.015 +0.0006	+0.007 +0.0003	0.007T 0.023T 0.0003T 0.0009T
+0.009 +0.0004	-0.004 -0.0002	0.004L 0.019T 0.0002L 0.0008T	+0.011 +0.0004	+0.002 +0.0001	0.002T 0.021T 0.0001T 0.0008T				+0.017 +0.0007	+0.008 +0.0003	0.008T 0.027T 0.0003T 0.0011T
+0.011 +0.0004	-0.005 -0.0002	0.005L 0.023T 0.0002L 0.00085T	+0.013 +0.0005	+0.002 +0.0001	0.002T 0.021T 0.0001T 0.0008T	+0.018 +0.0007	+0.002 +0.0001	0.002T 0.030T 0.0001T 0.00115T	+0.020 +0.0008	+0.009 +0.0004	0.009T 0.032T 0.0004T 0.00125T
+0.012 +0.0005	-0.007 -0.0003	0.007L 0.027T 0.0003L 0.0011T	+0.015 +0.0006	+0.002 +0.0001	0.002T 0.030T 0.0001T 0.0012T	+0.021 +0.0008	+0.002 +0.0001	0.002T 0.036T 0.0001T 0.0014T	+0.024 +0.0009	+0.011 +0.0004	0.011T 0.039T 0.0004T 0.0015T
+0.013 +0.0005	-0.009 -0.0004	0.009L 0.033T 0.0004L 0.0013T	+0.018 +0.0007	+0.003 +0.0001	0.003T 0.038T 0.0001T 0.0015T	+0.025 +0.0010	+0.003 +0.0001	0.003T 0.045T 0.0001T 0.0018T	+0.028 +0.0011	+0.013 +0.0005	0.013T 0.048T 0.0005T 0.0019T
+0.014 +0.0006	-0.011 -0.0004	0.011L 0.039T 0.0004L 0.0016T	+0.021 +0.0008	+0.003 +0.0001	0.003T 0.046T 0.0001T 0.0018T	+0.028 +0.0011	+0.003 +0.0001	0.003T 0.053T 0.0001T 0.0021T	+0.033 +0.0013	+0.015 +0.0006	0.015T 0.058T 0.0006T 0.0023T
+0.016 +0.0006	-0.013 -0.0005	0.013L 0.046T 0.0005L 0.0018T	+0.024 +0.0009	+0.004 +0.0002	0.003T 0.046T 0.0001T 0.0018T				+0.037 +0.0015	+0.017 +0.0007	0.017T 0.067T 0.0007T 0.0027T
+0.016 +0.0006	-0.013 -0.0005	0.013L 0.046T 0.0005L 0.0018T	+0.024 +0.0009	+0.004 +0.0002	0.003T 0.046T 0.0001T 0.0018T				+0.037 +0.0015	+0.017 +0.0007	0.017T 0.067T 0.0007T 0.0027T
+0.016 +0.0006	-0.013 -0.0005	0.013L 0.046T 0.0005L 0.0018T	+0.024 +0.0009	+0.004 +0.0002	0.003T 0.046T 0.0001T 0.0018T				+0.037 +0.0015	+0.017 +0.0007	0.017T 0.067T 0.0007T 0.0027T
+0.016 +0.0006	-0.016 -0.0006	0.016L 0.051T 0.0006L 0.0020T	+0.027 +0.0011	+0.004 +0.0002	0.004T 0.062T 0.0002T 0.0025T				+0.043 +0.0017	+0.020 +0.0008	0.020T 0.078T 0.0008T 0.0031T
+0.016 +0.0006	-0.016 -0.0006	0.016L 0.051T 0.0006L 0.0020T	+0.027 +0.0011	+0.004 +0.0002	0.004T 0.062T 0.0002T 0.0025T				+0.043 +0.0017	+0.020 +0.0008	0.020T 0.078T 0.0008T 0.0031T

Continued on next page.

SHAFT AND HOUSING TOLERANCES ABMA STANDARD 7

Shaft tolerances: radial ball, spherical and cylindrical roller bearings

Bearing Bore			g6			h6			j5		
Nominal (Max.)		Tolerance 0.000 mm 0.0000 in. To	Shaft Diameter		Fit	Shaft Diameter		Fit	Shaft Diameter		Fit
Over	Incl.		Max.	Min.		Max.	Min.		Max.	Min.	
mm		mm in.	mm in.			mm in.			mm in.		
315	355	-0.040 -0.0016	-0.018 -0.0007	-0.054 -0.0021	0.054L 0.022T 0.0021L 0.0009T	0.000 0.0000	-0.036 -0.0014	0.036L 0.040T 0.0014L 0.0016T	+0.007 +0.0003	-0.018 -0.0007	0.018L 0.047T 0.0007L 0.0019T
355	400	-0.040 -0.0016	-0.018 -0.0007	-0.054 -0.0021	0.054L 0.022T 0.0021L 0.0009T	0.000 0.0000	-0.036 -0.0014	0.036L 0.040T 0.0014L 0.0016T	+0.007 +0.0003	-0.018 -0.0007	0.018L 0.047T 0.0007L 0.0019T
400	450	-0.045 -0.0018	-0.020 -0.0008	-0.060 -0.0024	0.060L 0.025T 0.0024L 0.0010T	0.000 0.0000	-0.040 -0.0016	0.040L 0.045T 0.0016L 0.0018T	+0.007 +0.0003	-0.020 -0.0008	0.020L 0.052T 0.0008L 0.0021T
450	500	-0.045 -0.0018	-0.020 -0.0008	-0.060 -0.0024	0.060L 0.025T 0.0024L 0.0010T	0.000 0.0000	-0.040 -0.0016	0.040L 0.045T 0.0016L 0.0018T	+0.007 +0.0003	-0.020 -0.0008	0.020L 0.065T 0.0008L 0.0021T
500	560	-0.050 -0.0020	-0.022 -0.0009	-0.066 -0.0026	0.066L 0.028T 0.0026L 0.0011T	0.000 0.0000	-0.044 -0.0017	0.044L 0.050T 0.0017L 0.0020T	+0.008 +0.0003	-0.022 -0.0009	0.022L 0.058T 0.0009L 0.0023T
560	630	-0.050 -0.0020	-0.022 -0.0009	-0.066 -0.0026	0.066L 0.028T 0.0026L 0.0011T	0.000 0.0000	-0.044 -0.0017	0.044L 0.050T 0.0017L 0.0020T	+0.008 +0.0003	-0.022 -0.0009	0.022L 0.058T 0.0009L 0.0023T
630	710	-0.075 -0.0030	-0.024 -0.0009	-0.074 -0.0029	0.074L 0.051T 0.0029L 0.0021T	0.000 0.0000	-0.050 -0.0020	0.050L 0.075T 0.0020L 0.0030T	+0.010 +0.0004	-0.025 -0.0010	0.25L 0.85T 0.0010L 0.0034T
710	800	-0.075 -0.0030	-0.024 -0.0009	-0.074 -0.0029	0.074L 0.051T 0.0029L 0.0021T	0.000 0.0000	-0.050 -0.0020	0.050L 0.075T 0.0020L 0.0030T	+0.010 +0.0004	-0.025 -0.0010	0.025L 0.085T 0.0010L 0.0034T
800	900	-0.100 -0.0039	-0.026 -0.0010	-0.082 -0.0032	0.082L 0.074T 0.0032L 0.0029T	0.000 0.0000	-0.056 -0.0022	0.056L 0.100T 0.0022L 0.0039T	+0.012 +0.0005	-0.028 -0.0011	0.028L 0.112T 0.0011L 0.0044T
900	1000	-0.100 -0.0039	-0.026 -0.0010	-0.082 -0.0032	0.082L 0.074T 0.0032L 0.0029T	0.000 0.0000	-0.056 -0.0022	0.056L 0.100T 0.0022L 0.0039T	+0.012 +0.0005	-0.028 -0.0011	0.028L 0.112T 0.0011L 0.0044T
1000	1120	-0.125 -0.0049	-0.028 -0.0011	-0.094 -0.0037	0.094L 0.097T 0.0037L 0.0038T	0.000 0.0000	-0.066 -0.0026	0.066L 0.125T 0.0022L 0.0039T	+0.013 +0.0005	-0.033 -0.0013	0.033L 0.138T 0.0013L 0.0054T
1120	1250	-0.125 -0.0049	-0.028 -0.0011	-0.094 -0.0037	0.094L 0.097T 0.0037L 0.0038T	0.000 0.0000	-0.066 -0.0026	0.066L 0.125T 0.0022L 0.0039T	+0.013 +0.0005	-0.033 -0.0013	0.033L 0.138T 0.0013L 0.0054T

SHAFT AND HOUSING TOLERANCES ABMA STANDARD 7

j6			k5			m5		
Shaft Diameter		Fit	Shaft Diameter		Fit	Shaft Diameter		Fit
Max.	Min.		Max.	Min.		Max.	Min.	
mm in.			mm in.			mm in.		
+0.018 +0.0007	-0.018 -0.0007	0.018L 0.058T 0.0007L 0.0023T	+0.029 +0.0011	+0.046 +0.0002	0.004T 0.009T 0.0002T 0.0027T	+0.046 +0.0018	+0.021 +0.0008	0.021T 0.086T 0.0008T 0.0034T
+0.018 +0.0007	-0.018 -0.0007	0.018L 0.058T 0.0007L 0.0023T	+0.029 +0.0011	+0.004 +0.0002	0.004T 0.009T 0.0002T 0.0027T	+0.046 +0.0018	+0.021 +0.0008	0.021T 0.086T 0.0008T 0.0034T
+0.020 +0.0008	-0.020 -0.0008	0.020L 0.065T 0.0008L 0.0026T	+0.032 +0.0013	+0.005 +0.0002	0.005T 0.077T 0.0002T 0.0031T	+0.050 +0.0020	+0.023 +0.0009	0.021T 0.086T 0.0009T 0.0038T
+0.020 +0.0008	-0.020 -0.0008	0.020L 0.065T 0.0008L 0.0026T	+0.032 +0.0013	+0.005 +0.0002	0.005T 0.077T 0.0002T 0.0031T	+0.050 +0.0020	+0.023 +0.0009	0.021T 0.086T 0.0009T 0.0038T
+0.022 +0.0009	-0.022 -0.0009	0.022L 0.072T 0.0009L 0.0029T	+0.030 +0.0012	0.000 0.0000	0.000T 0.080T 0.0000T 0.0032T	+0.056 +0.0022	+0.026 +0.0010	0.026T 0.106T 0.0010T 0.0042T
+0.022 +0.0009	-0.022 -0.0009	0.022L 0.072T 0.0009L 0.0029T	+0.030 +0.0012	0.000 0.0000	0.000T 0.080T 0.0000T 0.0032T	+0.056 +0.0022	+0.026 +0.0010	0.026T 0.106T 0.0010T 0.0042T
+0.025 +0.0010	-0.025 -0.0010	0.025L 0.100T 0.0010L 0.0040T	+0.035 +0.0014	0.000 0.0000	0.000T 0.110T 0.0000T 0.0044T	+0.028 +0.0026	+0.013 +0.0012	0.030T 0.140T 0.0012T 0.0056T
+0.025 +0.0010	-0.025 -0.0010	0.025L 0.100T 0.0010L 0.0040T	+0.035 +0.0014	0.000 0.0000	0.000T 0.110T 0.0000T 0.0044T	+0.028 +0.0026	+0.013 +0.0012	0.030T 0.140T 0.0012T 0.0056T
+0.025 +0.0010	-0.025 -0.0010	0.025L 0.100T 0.0010L 0.0040T	+0.035 +0.0014	0.000 0.0000	0.000T 0.110T 0.0000T 0.0044T	+0.028 +0.0026	+0.013 +0.0012	0.030T 0.140T 0.0012T 0.0056T
+0.028 +0.0011	-0.028 -0.0011	0.028L 0.128T 0.0011L 0.0050T	+0.040 +0.0016	0.000 0.0000	0.000T 0.140T 0.0000T 0.0055T	+0.074 +0.0029	+0.034 +0.0013	0.034T 0.174T 0.0013T 0.0068T
+0.028 +0.0011	-0.028 -0.0011	0.013L 0.046T 0.0005L 0.0018T	+0.040 +0.0016	0.000 0.0000	0.003T 0.046T 0.0001T 0.0018T	+0.074 +0.0029	+0.034 +0.0013	0.34T 0.174T 0.0013T 0.0068T
+0.033 +0.0013	-0.033 -0.0013	0.033L 0.158T 0.0013L 0.0054T	+0.046 +0.0018	0.000 0.0000	0.000T 0.171T 0.0000T 0.0067T	+0.086 +0.0034	+0.040 +0.0016	0.040T 0.211T 0.0016T 0.0083T

Continued on next page.



Shaft tolerances: radial ball, spherical and cylindrical roller bearings

Bearing Bore			m6			n6			p6			r6			r7		
Nominal (Max.)		Tolerance 0.000 mm 0.0000 in. To	Shaft Diameter		Fit	Shaft Diameter		Fit	Shaft Diameter		Fit	Shaft Diameter		Fit	Shaft Diameter		Fit
Over	Incl.		Max.	Min.		Max.	Min.		Max.	Min.		Max.	Min.		Max.	Min.	
mm		mm in.	mm in.		mm in.		mm in.		mm in.		mm in.		mm in.		mm in.		
3	6	-0.008 -0.0003															
6	10	-0.008 -0.0003															
10	18	-0.008 -0.0003															
18	30	-0.010 -0.0004															
30	50	-0.012 -0.0005	+0.025 +0.0010	+0.009 +0.0004	0.009T 0.037T 0.0004T 0.0145T												
50	80	-0.015 -0.0006	+0.030 +0.0012	+0.011 +0.0004	0.011T 0.045T 0.0004T 0.0018T	+0.039 +0.0015	+0.020 +0.0008	0.020T 0.054T 0.0008T 0.0021T									
80	120	-0.020 -0.0008	+0.035 +0.0014	+0.013 +0.0005	0.013T 0.055T 0.0005T 0.0022T	+0.045 +0.0018	+0.023 +0.0009	0.023T 0.065T 0.0009T 0.0026T	+0.059 +0.0023	+0.037 +0.0015	0.037T 0.079T 0.0015T 0.0031T						
120	180	-0.025 -0.0010	+0.040 +0.0016	+0.015 +0.0006	0.015T 0.065T 0.0006T 0.0026T	+0.052 +0.0020	+0.027 +0.0011	0.027T 0.077T 0.0011T 0.0030T	+0.068 +0.0027	+0.043 +0.0017	0.043T 0.093T 0.0017T 0.0037T	+0.090 +0.0035	-0.065 +0.0026	0.065T 0.115T 0.0026T 0.0045T			
180	200	-0.030 -0.0012	+0.046 +0.0018	+0.017 +0.0007	0.017T 0.076T 0.0007T 0.0030T	+0.060 +0.0024	+0.031 +0.0012	0.031L 0.090T 0.0012L 0.0036T	+0.079 +0.0031	+0.050 +0.0020	0.050T 0.109T 0.0020T 0.0043T	+0.106 +0.0042	+0.077 +0.0030	0.077T 0.136T 0.0030T 0.0054T			
200	225	-0.030 -0.0012	+0.046 +0.0018	+0.017 +0.0007	0.017T 0.076T 0.0007T 0.0030T	+0.060 +0.0024	+0.031 +0.0012	0.031L 0.090T 0.0012L 0.0036T	+0.079 +0.0031	+0.050 +0.0020	0.050T 0.109T 0.0020T 0.0043T	+0.109 +0.0043	+0.080 +0.0031	0.080T 0.139T 0.0031T 0.0055T	+0.126 +0.0050	+0.080 +0.0031	0.080T 0.156T 0.0031T 0.0062T
225	250	-0.030 -0.0012	+0.046 +0.0018	+0.017 +0.0007	0.017T 0.076T 0.0007T 0.0030T	+0.060 +0.0024	+0.031 +0.0012	0.031L 0.090T 0.0012L 0.0036T	+0.079 +0.0031	+0.050 +0.0020	0.050T 0.109T 0.0020T 0.0043T	+0.113 +0.0044	+0.084 +0.0033	0.084T 0.143T 0.0033T 0.0056T	+0.130 +0.0051	+0.084 +0.0033	0.084T 0.160T 0.0033T 0.0063T
250	280	-0.035 -0.0014	+0.052 +0.0020	+0.020 +0.0008	0.020T 0.087T 0.0008T 0.0034T	+0.066 +0.0026	+0.034 +0.0013	0.034T 0.101T 0.0013T 0.0040T	+0.088 +0.0035	+0.056 +0.0022	0.0056T 0.123T 0.0022T 0.0049T	+0.126 +0.0050	+0.094 +0.0037	0.094T 0.161T 0.0037T 0.0064T	+0.146 +0.0057	+0.094 +0.0037	0.094T 0.181T 0.0037T 0.0071T
280	315	-0.035 -0.0014	+0.052 +0.0020	+0.020 +0.0008	0.020T 0.087T 0.0008T 0.0034T	+0.066 +0.0026	+0.034 +0.0013	0.034T 0.101T 0.0013T 0.0040T	+0.088 +0.0035	+0.056 +0.0022	0.056T 0.123T 0.0022T 0.0049T	+0.130 +0.0051	+0.098 +0.0039	0.098T 0.165T 0.0039T 0.0065T	+0.150 +0.0059	+0.098 +0.0039	0.098T 0.185T 0.0039T 0.0073T

SHAFT AND HOUSING TOLERANCES ABMA STANDARD 7

Bearing Bore			m6			n6			p6			r6			r7		
Nominal (Max.)		Tolerance 0.000 mm 0.0000 in. To	Shaft Diameter		Fit	Shaft Diameter		Fit	Shaft Diameter		Fit	Shaft Diameter		Fit	Shaft Diameter		Fit
Over	Incl.		Max.	Min.		Max.	Min.		Max.	Min.		Max.	Min.		Max.	Min.	
mm		mm in.	mm in.		mm in.		mm in.		mm in.		mm in.		mm in.				
315	355	-0.040 -0.0016	+0.057 +0.0022	+0.021 +0.0008	0.021T 0.097T 0.0008T 0.0038T	+0.073 +0.0029	+0.037 +0.0015	0.037T 0.113T 0.0015T 0.0045T	+0.098 +0.0039	+0.062 +0.0024	0.062T 0.138T 0.0024T 0.0055T	+0.144 +0.0057	+0.108 +0.0043	0.108T 0.184T 0.0043T 0.0073T	+0.165 +0.0065	+0.108 +0.0043	0.108T 0.205T 0.0043T 0.0081T
355	400	-0.040 -0.0016				+0.073 +0.0029	+0.037 +0.0015	0.037T 0.113T 0.0015T 0.0045T	+0.098 +0.0039	+0.062 +0.0024	0.062T 0.138T 0.0024T 0.0055T	+0.150 +0.0059	+0.114 +0.0045	0.114T 0.190T 0.0045T 0.0075T	+0.171 +0.0067	+0.114 +0.0045	0.114T 0.211T 0.0045T 0.0083T
400	450	-0.045 -0.0018				+0.080 +0.0031	+0.040 +0.0016	0.040T 0.125T 0.0016T 0.0049T	+0.108 +0.0043	+0.068 +0.0027	0.068T 0.153T 0.0027T 0.0061T	+0.166 +0.0065	+0.126 +0.0050	0.126T 0.211T 0.0050T 0.0086T	+0.189 +0.0074	+0.126 +0.0050	0.126T 0.234T 0.0050T 0.0092T
450	500	-0.045 -0.0018				+0.080 +0.0031	+0.040 +0.0016	0.040T 0.125T 0.0016T 0.0049T	+0.108 +0.0043	+0.068 +0.0027	0.068T 0.153T 0.0027T 0.0061T	+0.172 +0.0068	+0.132 +0.0052	0.132T 0.217T 0.0052T 0.0086T	+0.195 +0.0077	+0.132 +0.0052	0.132T 0.240T 0.0052T 0.0095T
500	560	-0.050 -0.0020							+0.122 +0.0048	+0.078 +0.0031	0.078T 0.172T 0.0031T 0.0068T	+0.194 +0.0076	+0.150 +0.0059	0.150T 0.244T 0.0059T 0.0096T	+0.220 +0.0087	+0.150 +0.0059	0.150T 0.270T 0.0059T 0.0107T
560	630	-0.050 -0.0020							+0.122 +0.0048	+0.078 +0.0031	0.078T 0.172T 0.0031T 0.0068T	+0.199 +0.0078	+0.155 +0.0061	0.155T 0.249T 0.0061T 0.0098T	+0.225 +0.0089	+0.155 +0.0061	0.155T 0.275T 0.0061T 0.0109T
630	710	-0.075 -0.0030							+0.138 +0.0054	+0.088 +0.0035	0.088T 0.213T 0.0035T 0.0084T	+0.225 +0.0089	+0.175 +0.0069	0.175T 0.300T 0.0069T 0.0119T	+0.255 +0.0100	+0.175 +0.0069	0.175T 0.330T 0.0069T 0.0130T
710	800	-0.075 -0.0030							+0.138 +0.0054	+0.088 +0.0035	0.088T 0.213T 0.0035T 0.0084T	+0.235 +0.0093	+0.185 +0.0073	0.185T 0.310T 0.0073T 0.0123T	+0.265 +0.0104	+0.185 +0.0073	0.185T 0.340T 0.0073T 0.0134T
800	900	-0.100 -0.0039							+0.156 +0.0061	+0.100 +0.0039	0.100T 0.256T 0.0039T 0.0100T	+0.266 +0.0105	+0.210 +0.0083	0.210T 0.366T 0.0083T 0.0144T	+0.300 +0.0118	+0.210 +0.0083	0.210T 0.400T 0.0083T 0.0157T
900	1000	-0.100 -0.0039							+0.156 +0.0061	+0.100 +0.0039	0.100T 0.256T 0.0039T 0.0100T	+0.276 +0.0109	+0.220 +0.0087	0.220T 0.376T 0.0087T 0.0148T	+0.310 +0.0122	+0.220 +0.0087	0.220T 0.410T 0.0087T 0.0161T
1000	1120	-0.125 -0.0049							+0.186 +0.0073	+0.120 +0.0047	0.120T 0.311T 0.0047T 0.0122T	+0.316 +0.0124	+0.250 +0.0098	0.250T 0.441T 0.0098T 0.0173T	+0.355 +0.0140	+0.250 +0.0098	0.250T 0.480T 0.0098T 0.0189T
1120	1250	-0.125 -0.0049							+0.186 +0.0073	+0.120 +0.0047	0.120T 0.311T 0.0047T 0.0122T	+0.326 +0.0128	+0.260 +0.0102	0.260T 0.451T 0.0102T 0.0177T	+0.365 +0.0144	+0.260 +0.0102	0.260T 0.490T 0.0102T 0.0193T



SHAFT AND HOUSING TOLERANCES ABMA STANDARD 7

Housing tolerances: radial ball, spherical and cylindrical roller bearings

Bearing O.D.		F7				G7			H6			H7		
Nominal (Max.)		Tolerance 0.000 mm 0.0000 in. To	Housing Bore		Fit	Housing Bore		Fit	Housing Bore		Fit	Housing Bore		Fit
Over	Incl.		Max.	Min.		Max.	Min.		Max.	Min.		Max.	Min.	
mm		mm in.	mm in.		mm in.			mm in.			mm in.			
10	18	-0.008 -0.0003	+0.034 +0.0013	+0.016 +0.0006	0.016L 0.042L 0.0006L 0.0016L	+0.024 +0.0009	+0.002 +0.0002	0.006L 0.032L 0.0002L 0.0012L	+0.011 +0.0004	0.000 0.0000	0.000L 0.019L 0.0000L 0.0007L	+0.018 +0.0007	0.000 0.0000	0.000L 0.026L 0.0000L 0.0010L
18	30	-0.009 -0.0035	+0.041 +0.0016	+0.020 +0.0008	0.020L 0.050L 0.0008L 0.0195L	+0.028 +0.0011	+0.007 +0.0003	0.007L 0.037L 0.0003L 0.0145L	+0.013 +0.0008	0.000 0.0000	0.000L 0.022L 0.0000L 0.0085L	+0.021 +0.0008	0.000 0.0000	0.000L 0.030L 0.0000L 0.0115L
30	50	-0.011 -0.0045	+0.050 +0.0020	+0.025 +0.0010	0.025L 0.061L 0.0010L 0.0245L	+0.034 +0.0013	+0.009 +0.0004	0.009L 0.045L 0.0004L 0.0175L	+0.016 +0.0006	0.000 0.0000	0.000L 0.027L 0.0000L 0.0105L	+0.025 +0.0010	0.000 0.0000	0.000L 0.036L 0.0000L 0.0145L
50	80	-0.023 -0.0005	+0.060 +0.0024	+0.030 +0.0012	0.030L 0.073L 0.0012L 0.0029L	+0.040 +0.0016	+0.010 +0.0004	0.010L 0.053L 0.0004L 0.0021L	+0.019 +0.0007	0.000 0.0000	0.000L 0.032L 0.0000L 0.0012L	+0.030 +0.0012	0.000 0.0000	0.000L 0.059L 0.0000L 0.0023L
80	120	-0.015 -0.0006	+0.071 +0.0028	+0.036 +0.0014	0.036L 0.086L 0.0014L 0.0034L	+0.047 +0.0019	+0.012 +0.0005	0.012L 0.062L 0.0005L 0.0025L	+0.022 +0.0009	0.000 0.0000	0.000L 0.037L 0.0000L 0.0015L	+0.035 +0.0014	0.000 0.0000	0.000L 0.050L 0.0000L 0.0020L
120	150	-0.018 -0.0007	+0.083 +0.0033	+0.043 +0.0017	0.043L 0.101L 0.0017L 0.0040L	+0.054 +0.0021	+0.014 +0.0006	0.014L 0.072L 0.0006L 0.0028L	+0.025 +0.0010	0.000 0.0000	0.000L 0.043L 0.0000L 0.0017L	+0.040 +0.0016	0.000 0.0000	0.000L 0.058L 0.0000L 0.0023L
150	180	-0.025 -0.0010	+0.083 +0.0033	+0.043 +0.0017	0.043L 0.108L 0.0017L 0.0043L	+0.054 +0.0021	+0.014 +0.0006	0.014L 0.079L 0.0006L 0.0031L	+0.025 +0.0010	0.000 0.0000	0.000L 0.050L 0.0000L 0.0020L	+0.040 +0.0016	0.000 0.0000	0.000L 0.065L 0.0000L 0.0026L
180	250	-0.030 -0.0012	+0.096 +0.0038	+0.050 +0.0020	0.050L 0.126L 0.0020L 0.0050L	+0.061 +0.0024	+0.015 +0.0006	0.015L 0.091L 0.0006L 0.0036L	+0.029 +0.0011	0.000 0.0000	0.00L 0.059L 0.0000L 0.0023L	+0.046 +0.0018	0.000 0.0000	0.000L 0.076L 0.0000L 0.0030L
250	315	-0.035 -0.0014	+0.108 +0.0043	+0.056 +0.0022	0.056L 0.143L 0.0022L 0.0057L	+0.069 +0.0027	+0.017 +0.0007	0.017L 0.104L 0.0007L 0.0041L	+0.032 +0.0013	0.000 0.0000	0.000L 0.067L 0.0000L 0.0027L	+0.052 +0.0020	0.000 0.0000	0.000L 0.087L 0.0000L 0.0034L

NOTE: Tolerance and housing bore diameters are shown in the table as variances from nominal bearing O.D.

See pages 125-133 for actual shaft and housing diameters for normal loading of ABEC-1 and ABEC-3 radial ball bearings and 7000WN Series angular contact ball bearings.

See appropriate pages for particular operating conditions of radial ball (page 132), spherical (pages 92-93) and cylindrical roller bearings (page 104).

SHAFT AND HOUSING TOLERANCES ABMA STANDARD 7

H8			J6			J7			K6			K7		
Housing Bore		Fit	Housing Bore		Fit	Housing Bore		Fit	Housing Bore		Fit	Housing Bore		Fit
Max.	Min.		Max.	Min.		Max.	Min.		Max.	Min.		Max.	Min.	
mm in.			mm in.			mm in.			mm in.			mm in.		
+0.027 +0.0011	0.000 0.0000	0.000L 0.035L 0.0000L 0.0014L	+0.006 +0.0002	-0.005 -0.0002	0.005T 0.014L 0.0002T 0.0005L	+0.010 +0.0004	-0.008 -0.0003	0.008T 0.018L 0.0003T 0.0007L	+0.002 +0.0001	-0.009 -0.0004	0.009T 0.010L 0.0004T 0.0004L	+0.006 +0.0002	-0.012 -0.0005	0.012T 0.014L 0.0005T 0.0005L
+0.033 +0.0013	0.000 0.0000	0.000L 0.030L 0.0000L 0.0165L	+0.008 +0.0003	-0.005 -0.0002	0.005T 0.017L 0.0002T 0.0065L	+0.012 +0.0005	-0.009 -0.0004	0.009T 0.021L 0.0004T 0.0085L	+0.002 +0.0001	-0.011 -0.0004	0.011T 0.011L 0.0004T 0.0045L	+0.0006 +0.0002	-0.015 -0.0006	0.015T 0.015L 0.0006T 0.0055L
+0.039 +0.0015	0.000 0.0000	0.000L 0.050L 0.0000L 0.0195L	+0.010 +0.0002	-0.006 -0.0002	0.006T 0.021L 0.0002T 0.0085L	+0.014 +0.0006	-0.011 -0.0004	0.011T 0.025L 0.0004T 0.0105L	+0.003 +0.0001	-0.014 -0.0005	0.013T 0.014L 0.0005T 0.0055L	+0.007 +0.0003	-0.018 -0.0007	0.018T 0.018L 0.0007T 0.0075L
+0.046 +0.0018	0.000 0.0000	0.000L 0.069L 0.0000L 0.0023L	+0.013 +0.0005	-0.006 -0.0002	0.006T 0.026L 0.0002T 0.0010L	+0.018 +0.0007	-0.012 -0.0005	0.012T 0.031L 0.0005T 0.0012L	+0.004 +0.0002	-0.015 -0.0006	0.015T 0.017L 0.0006T 0.0007L	+0.0009 +0.0004	-0.021 -0.0008	0.021T 0.022L 0.0008T 0.0009L
+0.054 +0.0021	0.000 0.0000	0.000L 0.069L 0.0000L 0.0027L	+0.016 +0.0006	-0.006 -0.0002	0.006T 0.031L 0.0002T 0.0012L	+0.022 +0.0009	-0.013 -0.0005	0.013T 0.037L 0.0005T 0.0015L	+0.004 +0.0002	-0.018 -0.0007	0.018T 0.019L 0.0007T 0.0008L	+0.010 +0.0004	-0.025 -0.0010	0.025T 0.025L 0.0010T 0.0010L
+0.063 +0.0025	0.000 0.0000	0.000L 0.081L 0.0000L 0.0032L	+0.018 +0.0007	-0.007 -0.0003	0.007T 0.043L 0.0003T 0.0014L	+0.026 +0.0010	-0.014 -0.0006	0.014T 0.044L 0.0006T 0.0017L	+0.004 +0.0002	-0.021 -0.0008	0.021T 0.022L 0.0008T 0.0009L	+0.012 +0.0005	-0.028 -0.0011	0.028T 0.030L 0.0011T 0.0012L
+0.063 +0.0025	0.000 0.0000	0.000L 0.088L 0.0000L 0.0035L	+0.018 +0.0007	-0.007 -0.0003	0.007T 0.043L 0.0003T 0.0017L	+0.026 +0.0010	-0.014 -0.0006	0.014T 0.051L 0.0006T 0.0020L	+0.004 +0.0002	-0.021 -0.0008	0.021T 0.029L 0.0008T 0.0012L	+0.012 +0.0005	-0.028 -0.0011	0.028T 0.037L 0.0011T 0.0015L
+0.072 +0.0028	0.000 0.0000	0.000L 0.102L 0.0000L 0.0040L	+0.022 +0.0007	-0.007 -0.0003	0.007T 0.052L 0.0003T 0.0021L	+0.030 +0.0012	-0.016 -0.0006	0.016T 0.060L 0.0006T 0.0024L	+0.0005 +0.0002	-0.024 -0.0009	0.024T 0.035L 0.0009T 0.0014L	+0.013 +0.0005	-0.033 -0.0013	0.033T 0.043L 0.0013T 0.0017L
+0.081 +0.0032	0.000 0.0000	0.000L 0.116L 0.0000L 0.0046L	+0.025 +0.0010	-0.007 -0.0003	0.007T 0.060L 0.0003T 0.0024L	+0.036 +0.0014	-0.016 -0.0006	0.016T 0.071L 0.0006T 0.0028L	+0.005 +0.0002	-0.027 -0.0011	0.027T 0.040L 0.0011T 0.0016L	+0.016 +0.0006	-0.036 -0.0014	0.036T 0.051L 0.0014T 0.0020L

Continued on next page.



SHAFT AND HOUSING TOLERANCES ABMA STANDARD 7

Housing tolerances: radial ball, spherical and cylindrical roller bearings

Bearing O.D.		F7				G7			H8			H7		
Nominal (Max.)		Tolerance 0.000 mm 0.0000 in. To	Housing Bore		Fit	Housing Bore		Fit	Housing Bore		Fit	Housing Bore		Fit
Over	Incl.		Max.	Min.		Max.	Min.		Max.	Min.		Max.	Min.	
mm		mm in.	mm in.		mm in.			mm in.			mm in.			
315	400	-0.040 -0.0016	+0.119 +0.0047	+0.062 +0.0024	0.063L 0.159L 0.0024L 0.0062L	+0.075 +0.0030	+0.018 +0.0007	0.018L 0.115L 0.0007L 0.0046L	+0.089 +0.0035	0.000 0.0000	0.000L 0.129L 0.0000L 0.0051L	+0.057 +0.0022	0.000 0.0000	0.000L 0.097L 0.0000L 0.0038L
400	500	-0.045 -0.0018	+0.131 +0.0052	+0.068 +0.0027	0.068L 0.176L 0.0027L 0.0070L	+0.083 +0.0033	+0.020 +0.0008	0.020L 0.128L 0.0008L 0.0051L	+0.097 +0.0038	0.000 0.0000	0.000L 0.142L 0.0000L 0.0056L	+0.063 +0.0025	0.000 0.0000	0.000L 0.108L 0.0000L 0.0043L
500	630	-0.050 -0.0020	+0.146 +0.0057	+0.076 +0.0030	0.076L 0.196L 0.0030L 0.0077L	+0.092 +0.0036	+0.022 +0.0009	0.022L 0.142L 0.0009L 0.0056L	+0.110 +0.0043	0.000 0.0000	0.000L 0.160L 0.0000L 0.0063L	+0.070 +0.0028	0.000 0.0000	0.000L 0.120L 0.0000L 0.0048L
630	800	-0.075 -0.0030	+0.160 +0.0063	+0.080 +0.0031	0.080L 0.235L 0.0031L 0.0093L	+0.104 +0.0041	+0.024 +0.0009	0.024L 0.179L 0.0009L 0.0007L	+0.125 +0.0049	0.000 0.0000	0.000L 0.200L 0.0000L 0.0079L	+0.080 +0.0031	0.000 0.0000	0.000L 0.155L 0.0000L 0.0061L
800	1000	-0.100 -0.0039	+0.179 +0.0069	+0.086 +0.0034	0.086L 0.276L 0.0034L 0.0108L	+0.116 +0.0046	+0.026 +0.0010	0.026L 0.216L 0.0010L 0.0085L	+0.140 +0.0055	0.000 0.0000	0.000L 0.240L 0.0000L 0.0094L	+0.090 +0.0035	0.000 0.0000	0.000L 0.190L 0.0000L 0.0074L
1000	1250	-0.125 -0.0049	+0.203 +0.0080	+0.098 +0.0039	0.098L 0.328L 0.0039L 0.0129L	+0.133 +0.0052	+0.028 +0.0011	0.028L 0.258L 0.0011L 0.0101L	+0.165 +0.0065	0.000 0.0000	0.000L 0.290L 0.0000L 0.0114L	+0.105 +0.0041	0.000 0.0000	0.000L 0.230L 0.0000L 0.0090L
1250	1600	-0.160 -0.0063	+0.155 +0.0061	+0.030 +0.0012	0.110L 0.395L 0.0043L 0.0156L	+0.155 +0.0061	+0.030 +0.0012	0.030L 0.315L 0.0012L 0.0124L	+0.195 +0.0077	0.000 0.0000	0.000L 0.355L 0.0000L 0.0140L	+0.125 +0.0049	0.000 0.0000	0.000L 0.355L 0.0000L 0.0140L
1600	2000	-0.106 -0.0047	+0.270 +0.0106	+0.120 +0.0047	0.120L 0.470L 0.0047L 0.0185L	+0.182 +0.0072	+0.032 +0.0013	0.032L 0.382L 0.0013L 0.0151L	+0.230 +0.0091	0.000 0.0000	0.000L 0.430L 0.0000L 0.0170L	+0.150 +0.0059	0.000 0.0000	0.000L 0.350L 0.0000L 0.0138L
2000	2500	-0.250 -0.0098	+0.305 +0.0120	+0.130 +0.0051	0.130L 0.555L 0.0051L 0.0218L	+0.209 +0.0082	+0.034 +0.0013	0.034L 0.459L 0.0013L 0.0180L	+0.280 +0.0110	0.000 0.0000	0.000L 0.530L 0.0000L 0.0208L	+0.175 +0.0069	0.000 0.0000	0.000L 0.425L 0.0000L 0.0167L

E

H6			J6			J7			K6			K7		
Housing Bore		Fit	Housing Bore		Fit	Housing Bore		Fit	Housing Bore		Fit	Housing Bore		Fit
Max.	Min.		Max.	Min.		Max.	Min.		Max.	Min.		Max.	Min.	
mm in.			mm in.			mm in.			mm in.			mm in.		
+0.036 +0.0014	0.000 0.0000	0.000L 0.076L 0.0000L 0.0030L	+0.029 +0.0011	-0.007 -0.0003	0.007T 0.069L 0.0003T 0.0027L	+0.039 +0.0015	-0.018 -0.0007	0.018T 0.079L 0.0007T 0.0031L	+0.007 +0.0003	-0.029 -0.0011	0.029T 0.047L 0.0011T 0.0019L	+0.017 +0.0007	-0.040 -0.0016	0.040T 0.057L 0.0016T 0.0023L
+0.040 +0.0016	0.000 0.0000	0.000L 0.085L 0.0000L 0.0034L	+0.033 +0.0013	-0.007 -0.0003	0.007T 0.078L 0.0003T 0.0031L	+0.043 0.0017	-0.020 -0.0008	0.020T 0.088L 0.0008T 0.0035L	+0.008 +0.0003	-0.032 -0.0013	0.032T 0.053L 0.0013T 0.0021L	+0.018 +0.0007	-0.045 -0.0018	0.045T 0.063L 0.0018T 0.0025L
+0.044 +0.0017	0.000 0.0000	0.000L 0.094L 0.0000L 0.0037L	+0.037 +0.0015	-0.007 -0.0003	0.022T 0.098L 0.0009T 0.0039L	+0.048 +0.0019	-0.022 -0.0009	0.022T 0.098L 0.0009T 0.0039L	0.000 0.0000	-0.044 -0.0017	0.044T 0.050L 0.0017T 0.0020L	0.000 0.0000	-0.070 -0.0028	0.070T 0.050L 0.0028T 0.0029L
+0.050 +0.0020	0.000 0.0000	0.000L 0.125L 0.0000L 0.0050L	+0.040 +0.0016	-0.010 -0.0004	0.010T 0.115L 0.0004T 0.0046L	+0.056 +0.0022	-0.024 -0.0009	0.024T 0.131L 0.0009T 0.0052L	0.000 0.0000	-0.050 -0.0020	0.050T 0.075L 0.0020T 0.0030L	0.000 0.0000	-0.080 -0.0031	0.080T 0.075L 0.0031T 0.0030L
+0.056 +0.0022	0.000 0.0000	0.000L 0.156L 0.0000L 0.0061L	+0.046 +0.0018	-0.010 -0.0004	0.010T 0.146L 0.0004T 0.0057L	+0.064 +0.0025	-0.026 -0.0010	0.026T 0.164L 0.0010T 0.0064L	0.000 0.0000	-0.056 -0.0022	0.056T 0.100L 0.0022T 0.0039L	0.000 0.0000	-0.090 -0.0035	0.090T 0.100L 0.0035T 0.0039L
+0.066 +0.0026	0.000 0.0000	0.000L 0.191L 0.0000L 0.0075L	+0.056 +0.0022	-0.010 -0.0004	0.010T 0.181L 0.0004T 0.0071L	+0.077 +0.0030	-0.028 -0.0011	0.028T 0.202L 0.0011T 0.0079L	0.000 0.0000	-0.066 -0.0026	0.066T 0.125L 0.0026T 0.0049L	0.000 0.0000	-0.105 -0.0041	0.105T 0.125L 0.0041T 0.0049L
+0.078 +0.0031	0.000 0.0000	0.000L 0.238L 0.0000L 0.0094L	+0.068 +0.0027	-0.010 -0.0004	0.010T 0.228L 0.0004T 0.0090L	+0.095 +0.0037	-0.030 -0.0012	0.030T 0.255L 0.0012T 0.0100L	0.000 0.0000	-0.078 -0.0031	0.078T 0.160L 0.0031T 0.0063L	0.000 0.0000	-0.125 -0.0049	0.125T 0.160L 0.0049T 0.0063L
+0.092 +0.0036	0.000 0.0000	0.000L 0.292L 0.0000L 0.0115L	+0.082 +0.0032	-0.010 -0.0004	0.110T 0.282L 0.0004T 0.0111L	+0.118 +0.0046	-0.032 -0.0013	0.032T 0.318L 0.0013T 0.0125L	0.000 0.0000	-0.092 -0.0036	0.092T 0.200L 0.0036T 0.0079L	0.000 0.0000	-0.150 -0.0059	0.150T 0.200L 0.0059T 0.0079L
+0.110 +0.0043	0.000 0.0000	0.000L 0.360L 0.0000L 0.0141L	+0.100 +0.0039	-0.010 -0.0004	0.010T 0.350L 0.0004T 0.0137L	+0.141 +0.0056	-0.034 -0.0013	0.034T 0.391L 0.0013T 0.0154L	0.000 0.0000	-0.110 -0.0043	0.110T 0.250L 0.0043T 0.0098L	0.000 0.0000	-0.175 -0.0069	0.175T 0.250L 0.0069T 0.0098L



SHAFT AND HOUSING TOLERANCES ABMA STANDARD 7

Housing tolerances: radial ball, spherical and cylindrical roller bearings

Bearing O.D.			M6			M7			N6		
Nominal (Max.)		Tolerance 0.000 mm 0.0000 in. To	Housing Bore		Fit	Housing Bore		Fit	Housing Bore		Fit
Over	Incl.		Max.	Min.		Max.	Min.		Max.	Min.	
mm		mm in.	mm in.			mm in.			mm in.		
10	18	-0.008 -0.0003	-0.004 -0.0002	-0.015 -0.0006	0.015T 0.004L 0.0006T 0.0001L	0.000 0.0000	-0.018 -0.0007	0.018T 0.008L 0.0007T 0.0003L	-0.009 -0.0004	-0.020 -0.0008	0.020T 0.001T 0.0008T 0.0001T
18	30	-0.009 -0.0035	-0.004 -0.0002	-0.017 -0.0007	0.017T 0.005L 0.0007T 0.0015L	0.000 0.0000	-0.021 -0.0008	0.021T 0.009L 0.0008T 0.0035L	-0.007 -0.0004	-0.028 -0.0009	0.024T 0.002T 0.0009T 0.0005T
30	50	-0.011 -0.0045	-0.004 -0.0002	-0.020 -0.0008	0.020T 0.007L 0.0008T 0.0025L	0.000 0.0000	-0.025 -0.0010	0.025T 0.011L 0.0010T 0.0045L	-0.012 -0.0005	-0.028 -0.0011	0.028T 0.001T 0.0011T 0.0005T
50	80	-0.013 -0.0005	-0.005 -0.0002	-0.024 -0.0009	0.024T 0.008L 0.0009T 0.0003L	0.000 0.0000	-0.030 -0.0012	0.030T 0.013L 0.0012T 0.0005L	-0.014 -0.0006	-0.033 -0.0013	0.033T 0.001T 0.0013T 0.0001T
80	120	-0.015 -0.0006	-0.006 -0.0002	-0.028 -0.0011	0.028T 0.009L 0.0011T 0.0004L	0.000 0.0000	-0.035 -0.0014	0.035T 0.015L 0.0014T 0.0006L	-0.016 -0.0006	-0.038 -0.0015	0.038T 0.001T 0.0025T 0.0000T
120	150	-0.018 -0.0007	-0.008 -0.0003	-0.033 -0.0013	0.033T 0.010L 0.0013T 0.0004L	0.000 0.0000	-0.040 -0.0016	0.040T 0.018L 0.0016T 0.0007L	-0.020 -0.0008	-0.045 -0.0018	0.045T 0.002T 0.0018T 0.0001T
150	180	-0.025 -0.0010	-0.008 -0.0003	-0.033 -0.0013	0.033T 0.017L 0.0013T 0.0004L	0.000 0.0000	-0.040 -0.0016	0.040T 0.025L 0.0016T 0.0010L	-0.020 -0.0008	-0.045 -0.0018	0.045T 0.005T 0.0018T 0.0002T
180	250	-0.030 -0.0012	-0.008 -0.0003	-0.037 -0.0015	0.037T 0.022L 0.0015T 0.0009L	0.000 0.0000	-0.046 -0.0018	0.046T 0.030L 0.0018T 0.0012L	-0.022 -0.0009	-0.051 -0.0020	0.051T 0.008T 0.0020T 0.0003T
250	315	-0.035 -0.0014	-0.009 -0.0004	-0.041 -0.0016	0.041T 0.026L 0.0016T 0.0010L	0.000 0.0000	-0.052 -0.0020	0.052T 0.035L 0.0020T 0.0014L	-0.025 -0.0010	-0.057 -0.0022	0.057T 0.010T 0.0022T 0.0004T

E

N7			P6			P7		
Housing Bore		Fit	Housing Bore		Fit	Housing Bore		Fit
Max.	Min.		Max.	Min.		Max.	Min.	
mm in.			mm in.			mm in.		
-0.005 -0.0002	-0.023 -0.0009	0.023T 0.003L 0.0009T 0.0001L	-0.015 -0.0006	-0.026 -0.0010	0.026T 0.007T 0.0010T 0.0003T	-0.011 -0.0004	-0.029 -0.0011	0.029T 0.003T 0.0011T 0.0001T
-0.007 -0.0003	-0.028 -0.0011	0.028T 0.002L 0.0011T 0.0005L	-0.018 -0.0007	-0.031 -0.0012	0.031T 0.009T 0.0012T 0.00035T	-0.014 -0.0006	-0.035 -0.0014	0.035T 0.005T 0.0014T 0.00025T
-0.008 -0.0003	-0.033 -0.0013	0.033T 0.003L 0.0013T 0.0015L	-0.021 -0.0008	-0.037 -0.0015	0.037T 0.010T 0.0015T 0.00035T	-0.017 -0.0007	-0.042 -0.0017	0.042T 0.006T 0.0017T 0.00025T
-0.009 -0.0004	-0.039 -0.0015	0.039T 0.004L 0.0015T 0.0001L	-0.026 -0.0010	-0.045 -0.0018	0.045T 0.013T 0.0018T 0.0005T	-0.021 -0.0008	-0.051 -0.0020	0.051T 0.008T 0.0020T 0.0003T
-0.010 -0.0004	-0.045 -0.0018	0.045T 0.005L 0.0018T 0.0002L	-0.030 -0.0012	-0.052 -0.0020	0.052T 0.015T 0.0020T 0.0006T	-0.024 -0.0009	-0.059 -0.0023	0.059T 0.009T 0.0023T 0.0003T
-0.012 -0.0005	-0.052 -0.0020	0.061T 0.018L 0.0024T 0.0007L	-0.036 -0.0014	-0.061 -0.0024	0.061T 0.018T 0.0024T 0.0007T	-0.028 -0.0011	-0.068 -0.0027	0.068T 0.010T 0.0027T 0.0004T
-0.012 -0.0005	-0.052 -0.0020	0.052T 0.013L 0.0020T 0.0005L	-0.036 -0.0014	-0.061 -0.0024	0.061T 0.011T 0.0024T 0.0007T	-0.028 -0.0011	-0.068 -0.0027	0.068T 0.003T 0.0011T 0.0001T
-0.014 -0.0006	-0.060 -0.0024	0.060T 0.016L 0.0024T 0.0006L	-0.041 -0.0016	-0.070 -0.0028	0.070T 0.011T 0.0028T 0.0004T	-0.033 -0.0013	-0.079 -0.0031	0.079T 0.003T 0.0031T 0.0001T
-0.014 -0.0006	-0.066 -0.0026	0.066T 0.021L 0.0025T 0.0008L	-0.047 -0.0019	-0.079 -0.0031	0.079T 0.012T 0.0031T 0.0005T	-0.036 -0.0014	-0.088 -0.0035	0.088T 0.001T 0.0035T 0.0000T

Continued on next page.



SHAFT AND HOUSING TOLERANCES ABMA STANDARD 7

Housing tolerances: radial ball, spherical and cylindrical roller bearings

Bearing O.D.			M6			M7			N6		
Nominal (Max.)		Tolerance 0.000 mm 0.0000 in. To	Housing Bore		Fit	Housing Bore		Fit	Housing Bore		Fit
Over	Incl.		Max.	Min.		Max.	Min.		Max.	Min.	
mm		mm in.	mm in.			mm in.			mm in.		
315	400	-0.040 -0.0016	-0.010 -0.0004	-0.046 -0.0018	0.046T 0.030L 0.0018T 0.0012L	0.000 0.0000	-0.057 -0.0022	0.057T 0.040L 0.0022T 0.0016L	-0.026 -0.0006	-0.062 -0.0029	0.062T 0.014T 0.0024T 0.0006T
400	500	-0.045 -0.0018	-0.010 -0.0004	-0.050 -0.0020	0.050T 0.035L 0.0020T 0.0014L	0.000 0.0000	-0.063 -0.0025	0.063T 0.045L 0.0025T 0.0018L	-0.027 -0.0011	-0.067 -0.0026	0.067T 0.018T 0.0026T 0.0007T
500	630	-0.050 -0.0020	-0.026 -0.0010	-0.070 -0.0028	0.070T 0.024L 0.0028T 0.0010L	-0.026 -0.0010	-0.096 -0.0038	0.096T 0.024L 0.0038T 0.0010L	-0.044 -0.0017	-0.088 -0.0035	0.088T 0.006T 0.0035T 0.0003T
630	800	-0.075 -0.0030	-0.030 -0.0012	-0.080 -0.0031	0.080T 0.045L 0.0031T 0.0018L	-0.030 -0.0012	-0.110 -0.0043	0.110T 0.045L 0.0043T 0.0018L	-0.050 -0.0020	-0.100 -0.0039	0.100T 0.025T 0.0039T 0.0010T
800	1000	-0.100 -0.0039	-0.034 -0.0013	-0.090 -0.0035	0.090T 0.066L 0.0035T 0.0026L	-0.034 -0.0013	-0.124 -0.0049	0.124T 0.066L 0.0049T 0.0026L	-0.056 -0.0022	-0.112 -0.0044	0.112T 0.044T 0.0044T 0.0017T
1000	1250	-0.125 -0.0049	-0.040 -0.0016	-0.106 -0.0042	0.106T 0.085L 0.0042T 0.0033L	-0.040 -0.0016	-0.145 -0.0057	0.145T 0.085L 0.0057T 0.0033L	-0.066 -0.0026	-0.132 -0.0052	0.132T 0.059T 0.0052T 0.0023T
1250	1600	-0.160 -0.0063	-0.048 -0.0019	-0.126 -0.0050	0.126T 0.112L 0.0050T 0.0044L	-0.048 -0.0019	-0.173 -0.0068	0.173T 0.112L 0.0068T 0.0044L	-0.078 -0.0031	-0.156 -0.0061	0.156T 0.082T 0.0061T 0.0032T
1600	2000	-0.200 -0.0079	-0.058 -0.0023	-0.150 -0.0059	0.150T 0.142L 0.0059T 0.0056L	-0.058 -0.0023	-0.208 -0.0082	0.208T 0.142L 0.0082T 0.0056L	-0.092 -0.0036	-0.184 -0.0072	0.184T 0.108T 0.0072T 0.0043T
2000	2500	-0.250 -0.0098	-0.068 -0.0027	-0.178 -0.0070	0.178T 0.182L 0.0070T 0.0071L	-0.068 -0.0027	-0.243 -0.0096	0.243T 0.182L 0.0096T 0.0071L	-0.110 -0.0043	-0.220 -0.0087	0.285T 0.140T 0.112T 0.055T

E

N7			P6			P7		
Housing Bore		Fit	Housing Bore		Fit	Housing Bore		Fit
Max.	Min.		Max.	Min.		Max.	Min.	
mm in.			mm in.			mm in.		
-0.016 -0.0006	-0.073 -0.0029	0.073T 0.024L 0.0029T 0.0010L	-0.051 -0.0020	-0.087 -0.0034	0.087T 0.011T 0.0034T 0.0004T	-0.041 -0.0016	-0.098 -0.0039	0.098T 0.001T 0.0039T 0.0000T
-0.017 -0.0007	-0.080 -0.0031	0.080T 0.028L 0.0031T 0.0011L	-0.055 -0.0022	-0.095 -0.0037	0.095T 0.010T 0.0037T 0.0004T	-0.045 -0.0018	-0.108 -0.0043	0.108T 0.000T 0.0043T 0.0000T
-0.044 -0.0017	-0.114 -0.0045	0.114T 0.006L 0.0045T 0.0003L	-0.078 -0.0031	-0.122 -0.0048	0.122T 0.028T 0.0048T 0.0011T	-0.078 -0.0031	-0.148 -0.0058	0.148T 0.028T 0.0058T 0.0011T
-0.050 -0.0020	-0.130 -0.0051	0.130T 0.025L 0.0051T 0.0010L	-0.088 -0.0035	-0.138 -0.0054	0.138T 0.013T 0.0054T 0.0005T	-0.088 -0.0035	-0.168 -0.0066	0.168T 0.013T 0.0066T 0.0005T
-0.056 -0.0022	-0.146 -0.0057	0.146T 0.044L 0.0057T 0.0017L	-0.100 -0.0039	-0.156 -0.0061	0.156T 0.000T 0.0061T 0.0000T	-0.100 -0.0039	-0.190 -0.0075	0.190T 0.000T 0.0075T 0.0000T
-0.066 -0.0026	-0.171 -0.0067	0.171T 0.059L 0.0067T 0.0023L	-0.120 -0.0047	-0.186 -0.0073	0.186T 0.005L 0.0073T 0.0002L	-0.120 -0.0047	-0.225 -0.0089	0.225T 0.005T 0.0089T 0.0002T
-0.078 -0.0031	-0.203 -0.0080	0.203T 0.082L 0.0080T 0.0023L	-0.140 -0.0055	-0.218 -0.0086	0.218T 0.020L 0.0086T 0.0008L	-0.140 -0.0055	-0.265 -0.0104	0.265T 0.020L 0.0104T 0.0008L
-0.092 -0.0036	-0.242 -0.0095	0.242T 0.108L 0.0095T 0.0043L	-0.170 -0.0067	-0.262 -0.0103	0.262T 0.030L 0.0103T 0.0012L	-0.170 -0.0067	-0.320 -0.0126	0.320T 0.030L 0.0126T 0.0012L
-0.110 -0.0043	-0.285 -0.0112	0.285T 0.140L 0.0112T 0.0055L	-0.195 -0.0077	-0.305 -0.0120	0.305T 0.055L 0.0120T 0.0021L	-0.195 -0.0077	-0.370 -0.0146	0.370T 0.055L 0.0146T 0.0021L





TAPERED ROLLER BEARINGS



F TAPERED ROLLER BEARINGS

Tapered Roller Bearings.....	57
Storage And Handling.....	58
Removing Bearings.....	58
Installation.....	61
Shim Pack Fixtures.....	64
Fitting Practices.....	65

TAPERED ROLLER BEARINGS

F

F

TAPERED ROLLER BEARINGS

Timken offers the most extensive line of tapered roller bearings in the world. Tapered bearings consist of four interdependent components: the cone (inner ring), cup (outer ring), tapered rollers (rolling elements) and cage (roller retainer). They manage both thrust and radial loads on rotating shafts and are available in three configurations:

- **Single-row Tapered Roller Bearings:** Most basic and widely used tapered bearing. Usually fitted as one of an opposing pair. During equipment assembly, can be set to the required clearance (end play) or preload condition to optimize performance.
- **Double-row Bearings:** Two-row tapered bearing arrangements offer increased load capacity over single types.
- **Four-row Bearings:** Combine the inherent high-load, radial/thrust capacity and direct/indirect mounting variables of tapered roller bearings into assemblies of maximum load rating in a minimal space.

Sizes: 8 mm (0.315 in.) bore to 2222.5 mm (87.5 in.) outside diameter (O.D.).

Applications: Variety of industrial applications including rolling mills, crane wheels and sheaves.

Design Attributes: Available in single-, double- and four-row configurations. Custom surface geometries and coatings are available for enhanced performance.

Customer Benefits: Ability to manage both thrust and radial loads, providing for enhanced performance in demanding applications.



⚠ CAUTION Failure to observe the following cautions could create a risk of injury.

Do not attempt to disassemble unitized bearings.

Remove oil or rust inhibitor from parts before heating to avoid fire or fumes.

If a hammer and bar are used for installation or removal of a part, use a mild steel bar (e.g. 1010 or 1020 grade). Mild steel bars are less likely to cause release of high speed fragments from the hammer, bar or the bearing.

⚠ WARNING Failure to observe the following warnings could create a risk of serious bodily harm.

Tensile stresses can be very high in tightly fitted bearing components. Attempting to remove such components by cutting the cone (inner race) may result in a sudden shattering of the component causing fragments of metal to be forcefully expelled.

Always use properly guarded presses or bearing pullers to remove bearings from shafts, and always use suitable personal protective equipment, including safety glasses.



Fig. 17. Hydraulic bearing puller.

STORAGE AND HANDLING

See the General Bearing Handling and Inspection Section of this manual for general guidelines regarding how to handle bearings.

New Timken bearings are normally distributed in packaging that provides necessary protection against dirt and moisture. There is no need to wash new bearings because the rust preventive on the bearing is compatible with normal lubricants. To prevent bearing contamination, do not remove the bearing from its packaging until ready for installation, and do not leave open bearings lying on the floor or workbench.

Standard Timken packaging adequately protects bearings for up to five years, when stored in the original package under moderate temperature and humidity conditions. For longer storage life, or when extreme humidity or temperature exists, consult your Timken representative.

Tapered roller bearings include a cage that is susceptible to damage because it is not made of hardened steel. Mishandling or dropping the bearing can create damage that may result in significantly shorter bearing life.

REMOVING BEARINGS

Tapered roller bearings can frequently be reused if properly removed and cleaned before returning them to service. Remove bearings with extreme care. If not done correctly, you can damage the bearing, shaft and housing, requiring expensive repairs.

There are a variety of mechanical and hydraulic bearing pullers available (Fig. 17) to enable you to remove bearings. See the Maintenance Tools Section of this manual for more information.

When removing a bearing, the puller should be positioned against the back face of the inner ring assembly. Be careful that the puller does not contact the cage. This can be checked by hand rotating the cage once the puller is in position.

In some cases, the shaft shoulder extends as high as the inner ring rib O.D. In this case, special pullers are available that pull the bearing through the rollers. The puller segments are in two pieces that grip the back of the roller without contacting the cage. The adapter ring holds the split segments together and prevents them from spreading under load.

Information concerning special pullers or other removal devices can be obtained by contacting your local Timken representative.

F

Removal of rolling mill bearings

Heavy-duty TQO and TQIT bearings are four-row bearings designed specifically to handle exceptionally high loads like those found in the rolling mill industry. The large size and weight of bearings used in these applications pose special concerns during removal.

Handling these bearings requires a crane and some simple fixtures to safely conduct maintenance. Lifting fixtures can be used to remove the bearings from the chock and reinstall them after completing maintenance. Fig. 18 shows one style of fixture for TQO and TQIT bearings. This example is designed to lift the entire bearing. Other, more simple designs, can be used to handle the bearing one component or sub-assembly at a time.

TQIT tapered bore bearings

The TQIT bearing was developed for high-speed and precision rolling mills. Its tapered bore design permits a tight interference fit on the roll neck. This tight fit ensures greater stiffness in the design as well as greater accuracy for precision-type applications.

Most large bore bearings have threaded lifting holes in the cage ring that can be used to lift the inner ring assembly. Removing and assembling TQIT bearings is different because the inner ring has a tight fit on the roll neck. Hydraulic pressure should be used to remove and reinstall the inner ring assembly on the roll neck.

Detailed instructions on the care, handling and removal of large rolling mill bearings are available from your Timken representative.

Cleaning

See the General Bearing Handling and Inspection Section for information about proper cleaning and inspection techniques for all anti-friction bearings.

After a tapered roller bearing has been cleaned, dry it with compressed air. The air stream should be directed from one end of the roller to the other while holding the cage with your thumb to prevent the cage from spinning (Fig. 19). Make certain there is no water in the air line. Spraying a bearing with moist air can result in rust or corrosion.

Careful attention must be paid to the condition of the large roller end.

To reduce bearing contamination from other sources, all parts of the housing, shaft and gears should also be thoroughly cleaned.

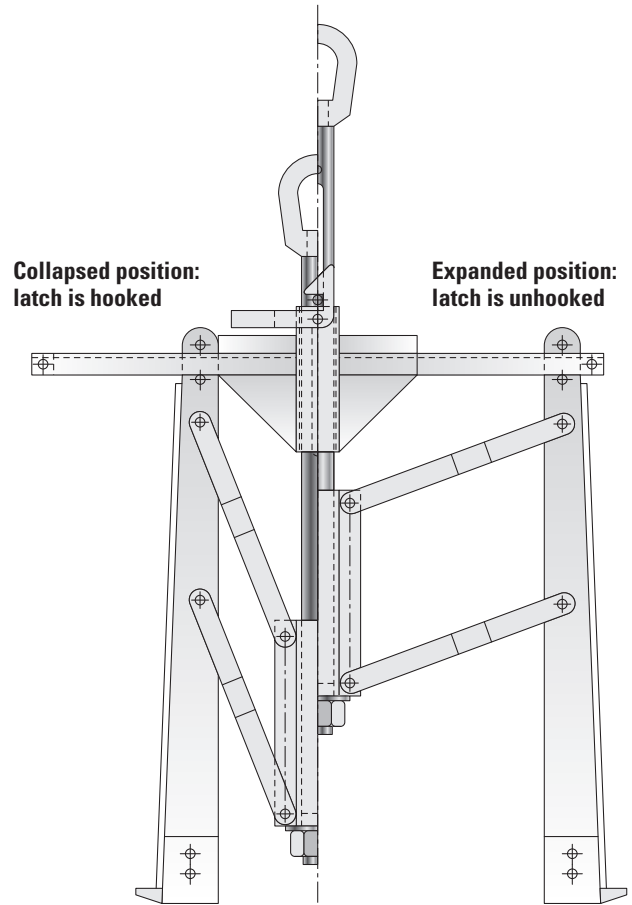

Fig. 18. Lifting fixture for TQO and TQIT bearings.



Fig. 19. Drying a bearing.

WARNING Failure to observe the following warnings could create a risk of serious bodily harm.

Never spin a bearing with compressed air. The rolling elements may be forcefully expelled.

Inspection

After cleaning the bearing, housing and shaft, and ensuring that the seats and backing are in good condition, evaluate the bearing to determine if it can be reinstalled or should be replaced. Bearings should be replaced if they show:

- Fatigue spalling
- Heat discoloration
- Rust
- Damaged cage
- Noticeable wear

While it may be possible to return bearings with these conditions to service, there is increased risk of bearing damage after the unit is reassembled.

All components of the tapered roller bearing must be closely inspected before returning the bearing to service (Fig. 20). The O.D. of the outer ring and I.D. of the inner ring should be inspected for any nicks or burrs that may interfere with the fit when reinstalling the components.

The race of the outer ring should be inspected for any unusual wear. Special attention should be given to identifying any nicks or spalls in the race. These types of damage can quickly propagate, leading to equipment failure.

The surface of each roller should be inspected for unusual wear or spalls.

On the inner race, inspect the large rib for damage, wear or discoloration. The rib provides an essential role in maintaining proper bearing function. Also inspect the race of the inner ring.

On smaller bearings, the rollers and cage prevent you from getting a clear view of the inner ring race. You can check for nicks or spalls by using a metal probe inserted in the small end of the inner ring to feel for damage on the race. A paper clip with a 90-degree bend in the end will serve the same purpose. Slide the probe under the small end of the cage and work it back and forth across the cone race. Spalls and nicks are caught quite easily with this tool.

Larger bearings may have one inspection roller that is held in place with removable pins that are not welded in place. These threaded pins can be removed by prying out the locking wire and screwing the pin out. By removing these pins and the roller, it will allow you to conduct a more thorough inspection of the inner ring race. After completing the inspection, reinstall the inspection roller and retighten the threaded pins and the locking wire.



Fig. 20. Bearings must be inspected before returning to service.

Seals

If the unit uses seals or closures, they should also be inspected for wear or damage. Worn seals can allow dirt or water to enter the bearing. In most instances, seals are automatically replaced when a bearing is torn down for inspection. Inspect the seal surface on the shaft to ensure it is in good shape and working properly. Timken offers a full line of industrial seals. Contact your Timken representative for more information.

Bearing damage

Bearings may become damaged through improper handling and storage or through normal wear in use despite taking proper precautions. Additional information is available in the General Bearing Handling and Inspection Section. There are also several resources available from Timken to assist you in analyzing bearing damage, including online resources at Timken.com and publications with photos representing common types of bearing damage. Contact your Timken representative to obtain a copy of the appropriate publication.

Small areas of corrosion or rust, and small nicks or spalls, can probably be repaired and the bearing returned to service. Large spalls on the bearing races will not be able to support the rollers under load, so repair of these areas is questionable. Spalls that exceed 25 to 30 percent of the width of the race are usually not repairable.

Timken provides bearing repair service that can economically repair bearings with a 450 mm (18 in.) O.D. or larger. This program can save a customer up to 60 percent of the cost of a new replacement bearing. Contact your Timken representative to learn more about Timken bearing repair service.

INSTALLATION

See the General Bearing Handling and Inspection Section for information about proper installation techniques for all anti-friction bearings.

Do not remove the bearing from its packaging until you are ready to mount it. The packaging provides protection from contamination.

Do not install bearings in a damaged or worn housing, or on a damaged or worn shaft. Inner and outer ring seat damage should be repaired by using properly fitted sleeves. Shafts can be built up by metal spray and remachined to the correct size. If there is not a press fit on the shaft, a weld overlay and re-grind process is recommended to bring the shaft back to specification.

Bearing fit

Mounting a tapered roller bearing with the proper fit helps ensure that it will meet performance expectations. In general, the rotating ring must be mounted with a tight fit. A loose fit is used on a stationary inner ring or on a double outer ring bearing, especially at the floating position.

Inner ring assemblies are usually mounted with a tight fit and should be pressed on the shaft using proper drivers (Fig. 21). When pressing the inner ring on the shaft, be careful to avoid any misalignment. Also ensure that the cage is not damaged. Cages are relatively fragile, and can be easily damaged by contact with the driver.

When outer rings are installed with a tight fit, they can be pressed into the housing with a simple driver. The driver should contact the face of the outer ring (Fig. 22).

In applications that require a tight fit, it can be easier to install the bearing if it is first heated to expand it slightly. See the General Bearing Handling and Inspection Section of this manual for more information about methods for heating bearings and pressing them into mountings.

Outer rings mounted in an aluminum housing must have a minimum tight fit of 0.001 times the outer ring O.D. For magnesium housings, the minimum tight fit must be 0.0015 times the outer ring O.D.

Precision bearings require a special fit that depends on its precision class. In addition to the proper fit and bearing alignment, desired accuracy of the spindle, outer ring and inner ring seat roundness, and square backing shoulders for both the inner and outer ring are critical. Unsatisfactory spindle runout may result if any of these areas are out of tolerance.

Rolling mill bearings also require special fitting practices, depending on the type of bearing involved.

See the Shaft and Housing Requirements Section of this manual for general information about checking and preparing shafts and housings prior to bearing installation.

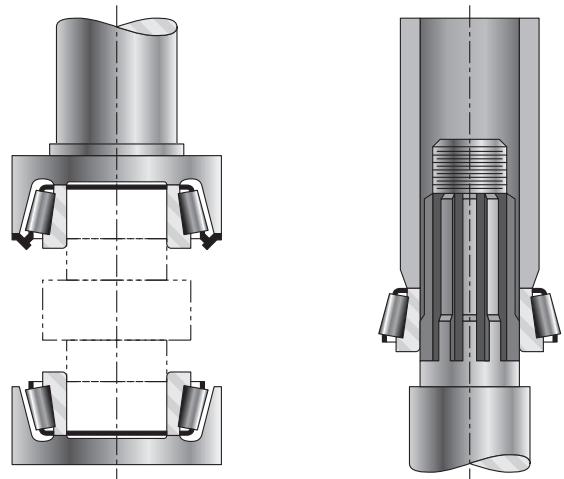

Fig. 21. Inner ring assemblies should be pressed on the shaft using the proper drivers.

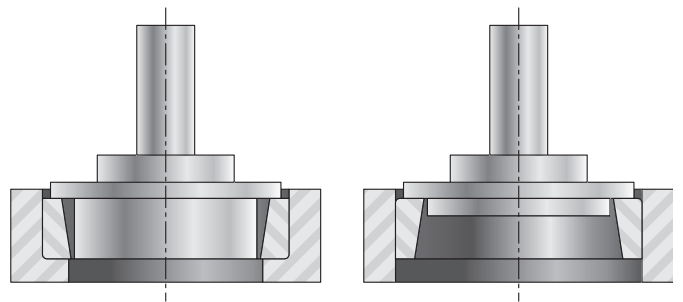

Fig. 22. Outer rings can be pressed into the housing with a simple driver.



Machined surface finishes for shafts and housings

The inner and outer ring seats should be smooth and within specified tolerances for size, roundness and taper. Ground finish is usually suggested for shafts whenever possible.

The suggested finish for ground and turned surfaces is:

- Inner ring seats –
Ground: 1.6 R_a micrometers
(65 microinches) maximum
- Inner ring seats –
Turned: 3.2 R_a micrometers
(125 microinches) maximum
- Outer ring seats –
Turned: 3.2 R_a micrometers
(125 microinches) maximum

Bearing seat finishes rougher than these limits reduce the contact area between the bearing and the seat. This can create a more loose fit, especially if the ring is pressed on and off several times.

Mounting

See the General Bearing Handling and Inspection Section for more information about mounting bearings, including methods to heat bearings or press them on/in using an arbor press.

When heating tapered roller bearings, inner ring temperatures should not exceed 120°C (250°F) for Standard Class bearings and 66°C (150°F) for Precision Class bearings. Higher temperatures can change the bearing's hardness and geometry.

Aluminum or magnesium housed outer rings require a tight fit. To ease installation, they can be reduced in size by freezing. Standard Class bearings should not be chilled below -54°C (-65°F), and Precision Class not below -29°C (-20°F).

Whenever inner or outer rings are heated or cooled during assembly, after mounting and returning to room temperature they should be checked with a 0.001 in. - 0.002 in. feeler gage. This ensures that the inner ring is pressed tightly against the shaft shoulder (Fig. 23) or the outer ring is pressed tightly against the housing shoulder. Before checking, ensure that both the inner and outer rings are pressed tightly against the shaft or housing shoulder.

When using a press to install bearings, avoid damage to the inner ring assembly. Tapered roller bearings should be separated (the inner ring assembly removed from the outer ring) during installation. When installing the inner ring assembly, use great care to ensure that no force is applied to the cage or rolling elements.

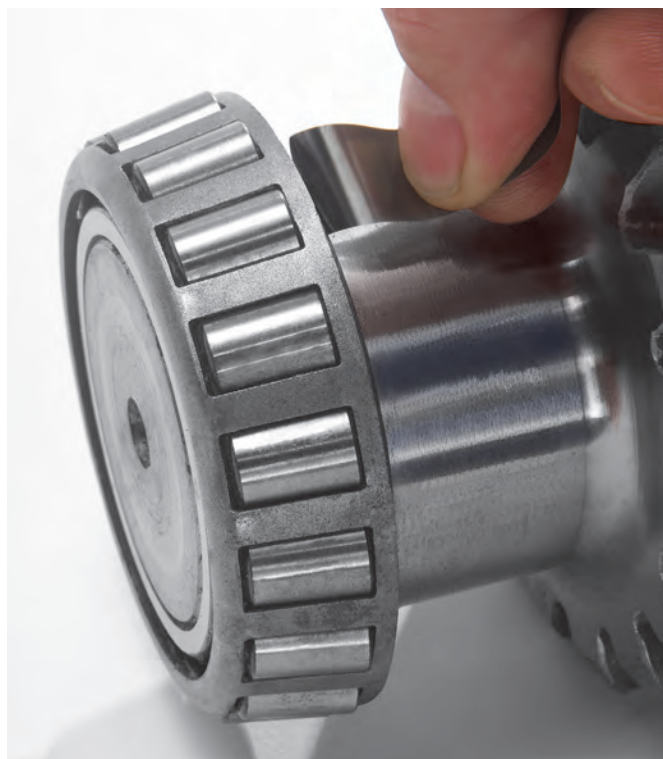

Fig. 23. Bearings should be checked with a feeler gage to ensure proper fit.

Tapered roller bearing adjustment techniques

One advantage of Timken tapered roller bearings is their setting can be adjusted for better performance in a given application. Some applications require a preload setting while other applications require end play. The amount of preload or end play depends on the particular application.

The proper bearing setting depends on many application requirements, including the flexibility of the housing and shaft, lubrication, speed, desired life and others. To determine the optimum bearing setting, refer to the original equipment manufacturer's maintenance and repair literature to determine the setting used in the original application.

Methods of measuring bearing setting

When bearing preload is required, the most convenient way to determine the preload is to read the torque from the shaft's rotation. To measure torque, wrap a string around a gear or other known diameter (Fig. 24). Attach a spring scale to the string and pull the spring scale to rotate the shaft at a slow, steady speed. Read the force indicated on the spring scale. Multiply the force times the radius to determine the bearing torque.

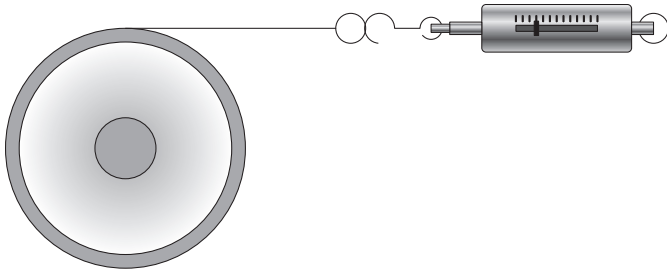

Fig. 24. Instrument to measure torque.

You can obtain a direct torque reading by using a torque wrench (Figures 25 and 26). If necessary, you can convert torque into preload force or dimensional preload. For assistance, contact your Timken representative.

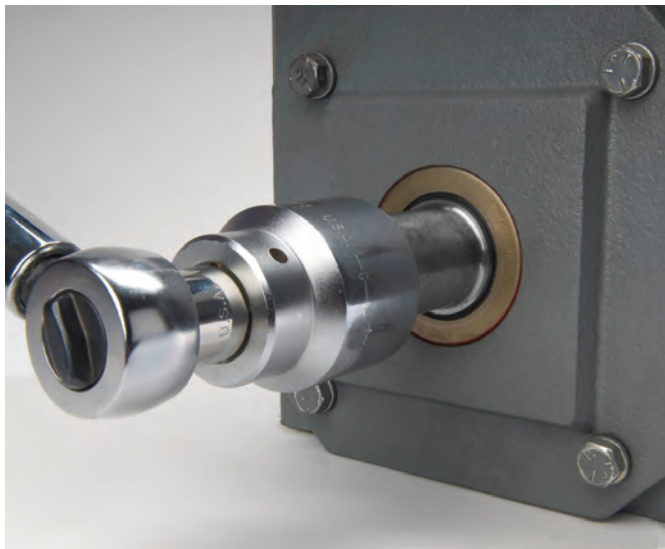

Fig. 25. Standard torque wrench.



Fig. 26. Electronic torque wrench.

Photo courtesy of Matco Tools

Bearing end play

If bearing end play is required, then a different method must be used to measure the amount of end play.

Locate a dial indicator against the end or shoulder on the shaft to measure the amount of axial movement (Fig. 27). Load the shaft in one direction and oscillate it several times while the load is applied. A handle can be mounted on the shaft to make it easier to apply the load while oscillating the shaft. Oscillate the shaft at least 20 times to firmly seat the bearings and ensure an accurate reading.



Fig. 27. Measure axial movement by locating a dial indicator against the end of the shaft.

After seating the bearings in one direction, set the indicator to zero. Then apply the load in the opposite direction, oscillating the shaft as before, and read any movement on the indicator. The difference between the two readings is the end play.

Adjusting the bearing

There are two common bearing adjustment methods: threaded shaft with a nut and a housing with an outer ring follower.

If end play is desired, back off the nut until no drag is felt. If the bearings are to be preloaded, advance the nut until the required torque is measured on the shaft.

Where shims are used, the bearing is set by tightening the end cap or bearing outer ring follower without shims in place until the bearings bind slightly while rotating. The gap between the end plate and the housing is measured with a feeler gage. This gap plus the desired end play will determine the total shim pack required.

SHIM PACK FIXTURES

Fixtures for determining the required amount of shims may be appropriate in high-production facilities where bearings are frequently adjusted. For most facilities, a simple fixture can be used to check the distance from the outer ring back face to the housing face. Compare this dimension to the outer ring follower in another fixture (Fig. 28). The difference between these dimensions determines the amount of shim pack, and takes into consideration the amount of end play or preload required for the application.

Determining cone spacer length TDO type

Some applications require a spacer between the two inner rings to obtain proper bearing adjustment. A simplified method of measuring the inner ring spacer length for a tapered double outer (TDO) bearing is described below. This method will result in an accurate measurement of dimension "B," which is the nominal width of the spacer.

Before beginning the measurement process, mark the "A" and "C" sides of the components as shown in Fig. 29. For proper measurement, it is important that the "A" inner ring is placed in the "A" side of the outer ring, and the "C" inner ring is placed in the "C" side of the outer ring.

The formula to calculate the "B" dimension is:

$$B = (AB + CB) - AC$$

Where:

- B = Distance between cone front faces
- AB = Distance between C cone front face and A cup face
- CB = Distance between A cone front face and C cup face
- AC = Cup length

Procedure

Place inner ring "C" with the back face (larger surface) down on a surface plate, and place the outer ring with the "C" face down on top of the inner race (Fig.29). Oscillate the outer race under load to seat the rollers firmly against the rib. Measure the AB distance (drop) using a depth micrometer or a dial indicator. Take measurements at four locations around the outer ring, at 12 o'clock, 3 o'clock, 6 o'clock and 9 o'clock and average them to get the average AB drop. Taking multiple readings provides greater accuracy and compensates for the possibility of a slightly misaligned outer ring.

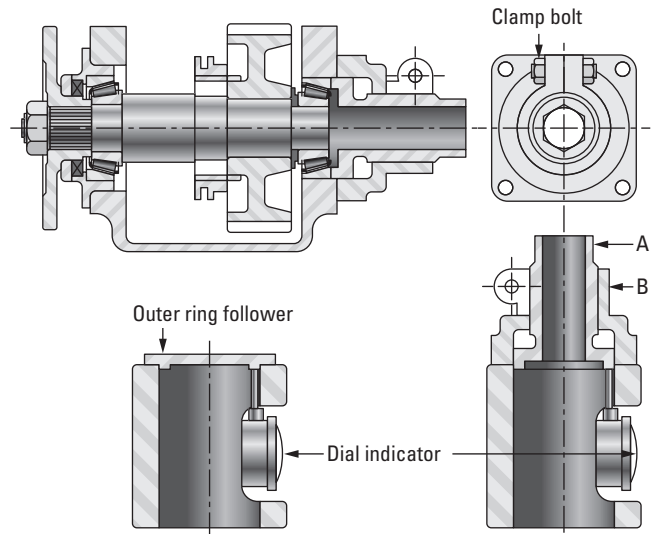

Fig. 28. Shim pack comparison.

Place inner ring "A" back face down on the surface plate. Move the outer ring, inverting it so the outer ring has side "A" down, and place it on inner ring "A." Oscillate the outer ring under load and measure the CB drop at four locations. Average these measurements to calculate the CB drop.

Use a parallel bar when measuring AB and CB, and be careful not to rotate the outer ring between measurements.

Measure the width of the outer ring at four locations and average them to determine the AC distance.

Calculate the B dimension. Add the desired end play amount, or subtract the desired preload. The resulting figure is the nominal spacer width needed to obtain the desired bearing setting. Grind the spacer to the nominal amount.

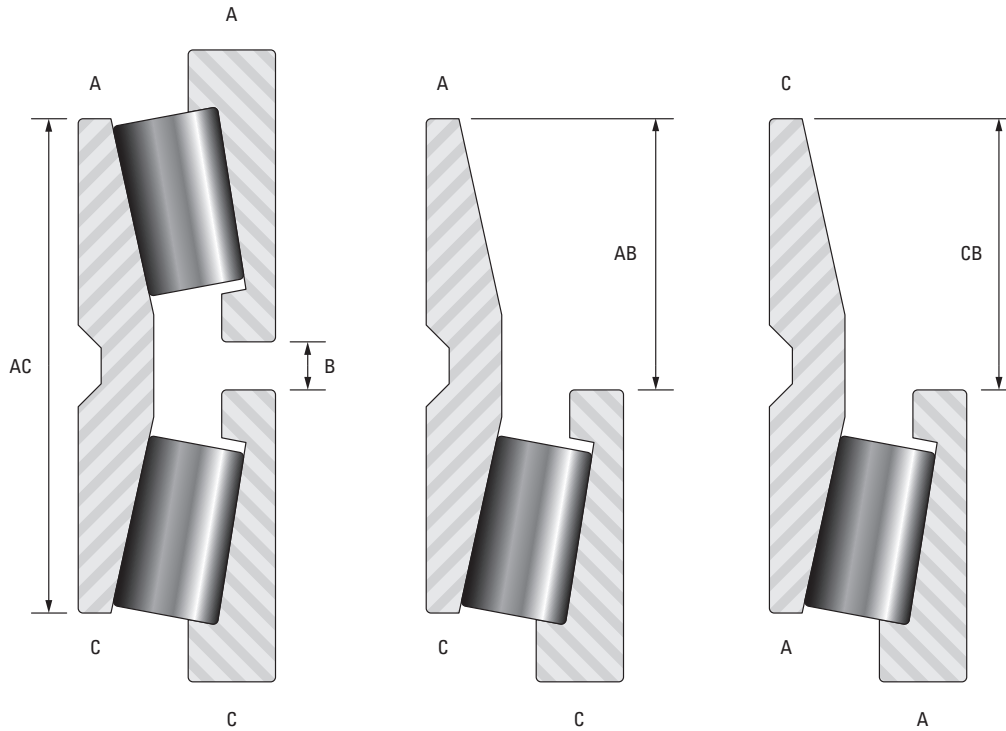

Fig. 29. Before beginning the measuring process, mark the “A” and “C” sides of the components.

Tapered roller bearings

The design of a Timken tapered roller bearing allows the setting of bearing internal clearance during installation to optimize bearing operation.

General industrial application fitting practice standards for cones and cups are shown in the following tables. These tables apply to solid or heavy-sectioned steel shafts, heavy-sectioned ferrous housings, and normal operating conditions. To use the tables, it is necessary to determine if the member is rotating or stationary, the magnitude, direction, and type of loading, and the shaft finish.

Certain table fits may not be adequate for light shaft and housing sections, shafts other than steel, nonferrous housings, critical operation conditions such as high speed, unusual thermal or loading conditions, or a combination thereof. Also, assembly procedures and the means and ease of obtaining the bearing setting may require special fits. In these cases, your Timken representative should be consulted for review and suggestions.

Rotating cones generally should be applied with an interference fit. In special cases loose fits may be considered if it has been determined by test or experience they will perform satisfactorily.

The term “rotating cone” describes a condition in which the cone rotates relative to the load. This may occur with a rotating cone under a stationary load or a stationary cone with a rotating load. Loose fits will permit the cones to creep and wear the shaft and the backing shoulder. This will result in excessive bearing looseness and possible bearing and shaft damage.

FITTING PRACTICES

Stationary cone fitting practice depends on the application. Under conditions of high speed, heavy loads or shock, interference fits using heavy-duty fitting practice, should be used. With cones mounted on unground shafts subjected to moderate loads (no shock) and moderate speeds, a metal-to-metal or near zero average fit is used. In sheave and wheel applications using unground shafts, or in cases using ground shafts with moderate loads (no shock), a minimum fit near zero to a maximum looseness which varies with the cone bore size is suggested. In stationary cone applications requiring hardened and ground spindles, a slightly looser fit may be satisfactory. Special fits may also be necessary on installations such as multiple sheave crane blocks.

Rotating cup applications where the cup rotates relative to the load should always use an interference fit.

TAPERED ROLLER BEARINGS

Stationary, nonadjustable and fixed single-row cup applications should be applied with a tight fit wherever practical. Generally, adjustable fits may be used where the bearing setup is obtained by sliding the cup axially in the housing bore. However, in certain heavy-duty, high-load applications, tight fits are necessary to prevent pounding and plastic deformation of the housing. Tightly fitted cups mounted in carriers can be used. Tight fits are suggested when the load rotates relative to the cup.

To permit through-boring when the outside diameters of single-row bearings mounted at each end of a shaft are equal and one is adjustable and the other fixed, it is suggested that the same adjustable fit be used at both ends. However, tight fits should be used if cups are backed against snap rings, to prevent excessive dishing of snap rings, groove wear and possible loss of ring retention. Only cups with a maximum housing fillet radius requirement of 1.3 mm (0.05 in.) or less should be considered for a snap ring backing.

Two-row stationary double cups are generally mounted with loose fits to permit assembly and disassembly. The loose fit also permits float when a floating bearing is mounted in conjunction with an axially fixed bearing on the other end of the shaft.

The fitting practice tables that follow have been prepared for both metric and inch dimensions.

For the inch system bearings, classes 4 and 2 (standard) and classes 3, 0, and 00 (precision) have been included.

The metric system bearings that have been included are classes K and N (metric system standard bearings) and classes C, B, and A (metric system precision bearings).

Precision class bearings should be mounted on shafts and in housings which are similarly finished to at least the same precision limits as the bearing bore and O.D. High quality surface finishes should also be provided.

Two-row and four-row bearings, which are provided with spacers and shipped as matched assemblies, have been preset to a specific bench end play. The specific end play setting is determined from a study of the bearing mounting and expected environment. It is dependent on the fitting practice and the required mounted bearing settings. Failure to use the designated fitting practice in the bearing application can result in improper bearing performance or sudden malfunction of the bearing, which may cause damage to machinery in which the bearing is a component.

For rolling mill roll neck fitting practice, consult your Timken representative. For all other equipment associated with the rolling mill industry, the fitting practice suggestions in the tables that follow should be used.

F

THIS PAGE IS INTENTIONALLY LEFT BLANK.

Class: 4 and 2 Cones

Cone Bore		Deviation From Minimum Cone Bore And Resultant Fit													
Range (mm/in.)		Tolerance (mm/in.) ⁽³⁾													
		Ground Seat		Unground Or Ground Seat		Unground Seat		Ground Seat		Unground Seat		Hardened And Ground Seat			
Constant Loads With Moderate Shock		Heavy Loads, Or High Speed Or Shock		Moderate Loads, No Shock		Moderate Loads, No Shock		Sheaves, Wheels, Idlers		Wheel Spindles					
Over	Incl.	Cone Seat Deviation	Resultant Fit	Cone Seat Deviation	Resultant Fit	Cone Seat Deviation	Resultant Fit	Cone Seat Deviation	Resultant Fit	Cone Seat Deviation	Resultant Fit	Cone Seat Deviation	Resultant Fit	Cone Seat Deviation	Resultant Fit
		mm in.	mm in.	mm in.	mm in.	mm in.	mm in.	mm in.	mm in.	mm in.	mm in.	mm in.	mm in.	mm in.	mm in.
0.000 0.0000	76.200 3.0000	0.000 +0.013 0.0000 +0.0005	+0.038 ⁽¹⁾ +0.025 +0.0015 +0.0010	0.038T 0.012T 0.0015T 0.0005T	+0.064 +0.038 +0.0025 +0.0015	0.064T 0.025T 0.0025T 0.0010T	+0.013 0.000 +0.0005 0.0000	0.013T 0.013L 0.0005T 0.0005L	0.000 -0.013 0.0000 -0.0005	0.000 0.026L 0.0000 0.0010L	0.000 -0.013 0.0000 -0.0005	0.000 0.026L 0.0000 0.0010L	-0.005 -0.018 -0.0002 -0.0007	0.005L 0.031L 0.0002L 0.0012L	
76.200 3.0000	304.800 12.0000	0.000 +0.025 0.0000 +0.0010	+0.064 +0.038 +0.0025 +0.0015	0.064T 0.013T 0.0025T 0.0005T	Use Average ⁽²⁾ Tight Cone Fit of 0.0005 mm/mm (0.0005 in./in.) of Cone Bore	+0.025 0.000 +0.0010 0.0000	0.025T 0.025L 0.0010T 0.0010L	0.000 -0.025 0.0000 -0.0010	0.000 0.050L 0.0000 0.0020L	0.000 -0.025 0.0000 -0.0010	0.000 0.050L 0.0000 0.0020L	-0.005 -0.030 -0.0002 -0.0012	0.005L 0.055L 0.0002L 0.0022L		
304.800 12.0000	609.600 24.0000	0.000 +0.051 0.0000 +0.0020	+0.127 +0.076 +0.0050 +0.0030	0.127T 0.025T 0.0050T 0.0010T		+0.051 0.000 +0.0020 0.0000	0.051T 0.051L 0.0020T 0.0020L	0.000 -0.051 0.0000 -0.0020	0.000 0.102L 0.0000 0.0040L	0.000 -0.051 0.0000 -0.0020	0.000 0.102L 0.0000 0.0040L	-	-		
609.600 24.0000	914.400 36.0000	0.000 +0.076 0.0000 +0.0030	+0.190 +0.114 +0.0075 +0.0045	0.190T 0.038T 0.0075T 0.0015T		+0.076 0.000 +0.0030 0.0000	0.076T 0.076L 0.0030T 0.0030L	0.000 -0.076 0.0000 -0.0030	0.000 0.152L 0.0000 0.0060L	0.000 -0.076 0.0000 -0.0030	0.000 0.152L 0.0000 0.0060L	-	-		

⁽¹⁾ Example: If the minimum cone bore is 76.200 mm (3.0000 in.), the suggested shaft size = 76.238 mm (3.0015 in.) to 76.225 mm (3.0010 in.) for a cone fit of 0.038 mm (0.0015 in.) tight to 0.012 mm (0.0005 in.) tight.

⁽²⁾ For cone bores between 76.200 mm (3.0000 in.) and 101.600 mm (4.0000 in.), use a minimum fit of 0.025 mm (0.001 in.) tight.

⁽³⁾ Does not apply to TNASW and TNASWE type bearings.

Class: 4 and 2 Cups

Cup O.D.		Deviation From Minimum Cup O.D. And Resultant Fit								
Range (mm/in.)		Tolerance (mm/in.)	Stationary Cup				Stationary Or Rotating Cup		Rotating Cup	
			Floating Or Clamped		Adjustable		Non Adjustable Or In Carriers, Sheaves - Clamped		Sheaves - Unclamped ⁽¹⁾	
Over	Incl.		Cup Seat Deviation	Resultant Fit	Cup Seat Deviation	Resultant Fit	Cup Seat Deviation	Resultant Fit	Cup Seat Deviation	Resultant Fit
		mm in.	mm in.		mm in.		mm in.		mm in.	
0.000 0.0000	76.200 3.0000	+0.025 0.000 +0.0010 0.0000	+0.051 +0.076 +0.0020 +0.0030	0.026L 0.076L 0.0010L 0.0030L	0.000 +0.025 0.0000 +0.0010	0.025T 0.025L 0.0010T 0.0010L	-0.038 -0.013 -0.0015 -0.0005	0.063T 0.013T 0.0025T 0.0005T	-0.076 -0.051 -0.0030 -0.0020	0.101T 0.051T 0.0040T 0.0020T
76.200 3.0000	127.000 5.0000	+0.025 0.000 +0.0010 0.0000	+0.051 +0.076 +0.0020 +0.0030	0.026L 0.076L 0.0010L 0.0030L	0.000 +0.025 0.0000 +0.0010	0.025T 0.025L 0.0010T 0.0010L	-0.051 -0.025 -0.0020 -0.0010	0.076T 0.025T 0.0030T 0.0010T	-0.076 -0.051 -0.0030 -0.0020	0.101T 0.051T 0.0040T 0.0020T
127.000 5.0000	304.800 12.0000	+0.025 0.000 +0.0010 0.0000	+0.051 +0.076 +0.0020 +0.0030	0.026L 0.076L 0.0010L 0.0030L	0.000 +0.051 0.0000 +0.0020	0.025T 0.051L 0.0010T 0.0020L	-0.051 -0.025 -0.0020 -0.0010	0.076T 0.025T 0.0030T 0.0010T	-0.076 -0.051 -0.0030 -0.0020	0.101T 0.051T 0.0040T 0.0020T
304.800 12.0000	609.600 24.0000	+0.051 0.000 +0.0020 0.0000	+0.102 +0.152 +0.0040 +0.0060	0.051L 0.152L 0.0020L 0.0060L	+0.026 +0.076 +0.0010 +0.0030	0.025T 0.076L 0.0010T 0.0030L	-0.076 -0.025 -0.0030 -0.0010	0.127T 0.025T 0.0050T 0.0010T	-0.102 -0.051 -0.0040 -0.0020	0.153T 0.051T 0.0060T 0.0020T
609.600 24.0000	914.400 36.0000	+0.076 0.000 +0.0030 0.0000	+0.152 +0.229 +0.0060 +0.0090	0.076L 0.229L 0.0030L 0.0090L	+0.051 +0.127 +0.0020 +0.0050	0.025T 0.127L 0.0010T 0.0050L	-0.102 -0.025 -0.0040 -0.0010	0.178T 0.025T 0.0070T 0.0010T	-	-

⁽¹⁾ Unclamped cup design is applicable only to sheaves with negligible fleet angle.



Class: 3 and 0 ⁽¹⁾ Cones

Cone Bore		Deviation From Minimum Cone Bore And Resultant Fit					
Range (mm/in.)		Tolerance (mm/in.)	Rotating Cone			Stationary Cone	
			Ground Seat		Ground Seat	Ground Seat	
Precision Machine Tool Spindles			Heavy Loads, Or High Speed Or Shock		Precision Machine Tool Spindles		
Over	Incl.		Cone Seat Deviation	Resultant Fit		Cone Seat Deviation	Resultant Fit
		mm in.	mm in.			mm in.	
0.000 0.0000	304.800 12.0000	0.000 +0.013 0.0000 +0.0005	+0.030 +0.018 +0.0012 +0.0007	0.030T 0.005T 0.0012T 0.0002T	Use Minimum Tight Cone Fit of 0.00025 mm/mm (0.00025 in./in.) of Cone Bore	+0.030 +0.018 +0.0012 +0.0007	0.030T 0.005T 0.0012T 0.0002T
304.800 12.0000	609.600 24.0000	0.000 +0.025 0.0000 +0.0010	+0.064 +0.038 +0.0025 +0.0015	0.064T 0.013T 0.0025T 0.0005T		+0.064 +0.038 +0.0025 +0.0015	0.064T 0.013T 0.0025T 0.0005T
609.600 24.0000	914.400 36.0000	0.000 +0.038 0.0000 +0.0015	+0.102 +0.064 +0.0040 +0.0025	0.102T 0.026T 0.0040T 0.0010T		+0.102 +0.064 +0.0040 +0.0025	0.102T 0.025T 0.0040T 0.0010T

⁽¹⁾ Maximum cone bore for Class 0 Product is 241.300 mm (9.5000 in.).

Class: 3 and 0 ⁽¹⁾ Cups

Cup O.D.		Deviation From Minimum Cup O.D. And Resultant Fit										
Range (mm/in.)		Tolerance (mm/in.)	Stationary Cup								Rotating Cup	
			Floating		Clamped		Adjustable		Nonadjustable Or In Carriers		Nonadjustable Or In Carriers	
Over	Incl.		Cup Seat Deviation	Resultant Fit	Cup Seat Deviation	Resultant Fit	Cup Seat Deviation	Resultant Fit	Cup Seat Deviation	Resultant Fit	Cup Seat Deviation	Resultant Fit
		mm in.	mm in.	mm in.	mm in.	mm in.	mm in.	mm in.	mm in.	mm in.	mm in.	
0.000 0.0000	152.400 6.0000	+0.013 0.000 +0.0005 0.0000	+0.025 +0.038 +0.0010 +0.0015	0.012L 0.038L 0.0005L 0.0015L	+0.013 +0.025 +0.0005 +0.0010	0.000 0.025L 0.0000 0.0010L	0.000 +0.013 0.0000 +0.0005	0.013T 0.013L 0.0005T 0.0005L	-0.013 0.000 -0.0005 0.0000	0.026T 0.000 0.0010T 0.0000	-0.025 -0.013 -0.0010 -0.0005	0.038T 0.013T 0.0015T 0.0005T
152.400 6.0000	304.800 12.0000	+0.013 0.000 +0.0005 0.0000	+0.025 +0.038 +0.0010 +0.0015	0.012L 0.038L 0.0005L 0.0015L	+0.013 +0.025 +0.0005 +0.0010	0.000 0.025L 0.0000 0.0010L	0.000 +0.025 0.0000 +0.0010	0.013T 0.013L 0.0005T 0.0010L	-0.025 0.000 -0.001 0.0000	0.038T 0.000 0.0015T 0.0000	-0.038 -0.013 -0.0015 -0.0005	0.051T 0.013T 0.0020T 0.0005T
304.800 12.0000	609.600 24.0000	+0.025 0.000 +0.0010 0.0000	+0.038 +0.064 +0.0015 +0.0025	0.013L 0.064L 0.0005L 0.0025L	+0.025 +0.051 +0.0010 +0.0020	0.000 0.051L 0.0000 0.0020L	0.000 +0.025 0.0000 +0.0010	0.025T 0.025L 0.0010T 0.0010L	-0.025 0.000 -0.001 0.0000	0.050T 0.000 0.0020T 0.0000	-0.038 -0.013 -0.0015 -0.0005	0.063T 0.013T 0.0025T 0.0005T
609.600 24.0000	914.400 36.0000	+0.038 0.000 +0.0015 0.0000	+0.051 +0.089 +0.0020 +0.0035	0.013L 0.089L 0.0005L 0.0035L	+0.038 +0.076 +0.0015 +0.0030	0.000 0.076L 0.0000 0.0030L	0.000 +0.038 0.0000 +0.0015	0.038T 0.038L 0.0015T 0.0015L	-0.038 0.000 -0.0015 0.0000	0.076T 0.000 0.0030T 0.0000	-0.051 -0.013 -0.0020 -0.0005	0.089T 0.013T 0.0035T 0.0005T

⁽¹⁾ Maximum cup O.D. for Class 0 product is 315.000 mm (12.4016 in.).



Class: 00 and 000 Cones

Cone Bore		Deviation From Minimum Cone Bore And Resultant Fit				
Range (mm/in.)		Tolerance (mm/in.)	Rotating Cone		Stationary Cone	
			Ground Seat		Ground Seat	
Precision Machine Tool Spindles			Precision Machine Tool Spindles			
Over	Incl.		Cone Seat Deviation	Resultant Fit	Cone Seat Deviation	Resultant Fit
		mm in.	mm in.		mm in.	
0.000 0.0000	315.000 12.4016	0.000 +0.008 0.0000 +0.0003	+0.020 +0.013 +0.0008 +0.0005	0.020T 0.005T 0.0008T 0.0002T	+0.020 +0.013 +0.0008 +0.0005	0.020T 0.005T 0.0008T 0.0002T

Class: 00 and 000 Cups

Cup O.D.		Deviation From Minimum Cup O.D. And Resultant Fit										
Range (mm/in.)		Tolerance (mm/in.)	Stationary Cup								Rotating Cup	
			Floating		Clamped		Adjustable		Nonadjustable Or In Carriers		Nonadjustable Or In Carriers	
Over	Incl.		Cup Seat Deviation	Resultant Fit	Cup Seat Deviation	Resultant Fit	Cup Seat Deviation	Resultant Fit	Cup Seat Deviation	Resultant Fit	Cup Seat Deviation	Resultant Fit
			mm in.	mm in.		mm in.		mm in.		mm in.		mm in.
0.000 0.0000	315.000 12.4016	+0.008 0.000 +0.0003 0.0000	+0.015 +0.023 +0.0006 +0.0009	0.007L 0.023L 0.0003L 0.0009L	+0.008 +0.015 +0.0003 +0.0006	0.000 0.015L 0.0000 0.0006L	0.000 +0.008 0.0000 +0.0003	0.008T 0.008L 0.0003T 0.0003L	-0.008 0.000 -0.0003 0.0000	0.016T 0.000 0.0006T 0.0000	-0.015 -0.008 -0.0006 -0.0003	0.023T 0.008T 0.0009T 0.0003T

THIS PAGE IS INTENTIONALLY LEFT BLANK.

Class: K and N Cones

Cone Bore		Deviation From Maximum Cone Bore And Resultant Fit									
Range (mm/in.)		Tolerance (mm/in.)	Rotating Cone			Rotating Or Stationary Cone			Stationary Cone		
			Ground Seat			Unground Seat Or Ground Seat			Unground Seat		
Over	Incl.		Constant Loads With Moderate Shock	Heavy Loads, High Speed Or Shock			Moderate Loads, No Shock				
		Cone Seat Deviation	Resultant Fit	Symbol	Cone Seat Deviation	Resultant Fit	Symbol	Cone Seat Deviation	Resultant Fit	Symbol	
		mm in.	mm in.		mm in.	mm in.		mm in.	mm in.		
10.000 0.3937	18.000 0.7087	-0.012 0.000 -0.0005 0.0000	+0.018 +0.007 +0.0007 +0.0003	0.030T 0.007T 0.0012T 0.0003T	m6	+0.023 +0.013 +0.0009 +0.0005	0.035T 0.013T 0.0014T 0.0005T	n6	0.000 -0.010 0.0000 -0.0004	0.012T 0.010L 0.0005T 0.0004L	h6
18.000 0.7087	30.000 1.1811	-0.012 0.000 -0.0005 0.0000	+0.021 +0.008 +0.0008 +0.0003	0.033T 0.008T 0.0013T 0.0003T	m6	+0.028 +0.015 +0.0011 +0.0006	0.040T 0.015T 0.0016T 0.0006T	n6	0.000 -0.013 0.0000 -0.0005	0.012T 0.013L 0.0005T 0.0005L	h6
30.000 1.1811	50.000 1.9685	-0.012 0.000 -0.0005 0.0000	+0.025 +0.009 +0.0010 +0.0004	0.037T 0.009T 0.0015T 0.0004T	m6	+0.033 +0.017 +0.0013 +0.0007	0.045T 0.017T 0.0018T 0.0007T	n6	0.000 -0.016 0.0000 -0.0006	0.012T 0.016L 0.0005T 0.0006L	h6
50.000 1.9685	80.000 3.1496	-0.015 0.000 -0.0006 0.0000	+0.030 +0.011 +0.0012 +0.0005	0.045T 0.011T 0.0018T 0.0005T	m6	+0.039 +0.020 +0.0015 +0.0008	0.053T 0.020T 0.0021T 0.0008T	n6	0.000 -0.019 0.0000 -0.0007	0.015T 0.019L 0.0006T 0.0007L	h6
80.000 3.1496	120.000 4.7244	-0.020 0.000 -0.0008 0.0000	+0.035 +0.013 +0.0014 +0.0005	0.055T 0.013T 0.0022T 0.0005T	m6	+0.045 +0.023 +0.0019 +0.0010	0.065T 0.023T 0.0027T 0.0010T	n6	0.000 -0.022 0.0000 -0.0009	0.020T 0.022L 0.0008T 0.0009L	h6
120.000 4.7244	180.000 7.0866	-0.025 0.000 -0.0010 0.0000	+0.052 +0.027 +0.0022 +0.0012	0.077T 0.027T 0.0032T 0.0012T	n6	+0.068 +0.043 +0.0028 +0.0018	0.093T 0.043T 0.0038T 0.0018T	p6	0.000 -0.025 0.0000 -0.0010	0.025T 0.025L 0.0010T 0.0010L	h6
180.000 7.0866	200.000 7.8740					+0.106 +0.077 +0.0042 +0.0030	0.136T 0.077T 0.0054T 0.0030T				
200.000 7.8740	225.000 8.8583	-0.030 0.000 -0.0012 0.0000	+0.060 +0.031 +0.0026 +0.0014	0.090T 0.031T 0.0038T 0.0014T	n6	+0.109 +0.080 +0.0043 +0.0031	0.139T 0.080T 0.0055T 0.0031T	r6	0.000 -0.029 0.0000 -0.0012	0.030T 0.029L 0.0012T 0.0012L	h6
225.000 8.8583	250.000 9.8425					+0.113 +0.084 +0.0044 +0.0033	0.143T 0.084T 0.0056T 0.0033T				

Deviation From Maximum Cone Bore And Resultant Fit								
Stationary Cone								
Ground Seat			Unground Seat			Hardened And Ground Seat		
Moderate Loads, No Shock			Sheaves, Wheels, Idlers			Wheel Spindles		
Cone Seat Deviation	Resultant Fit	Symbol	Cone Seat Deviation	Resultant Fit	Symbol	Cone Seat Deviation	Resultant Fit	Symbol
mm in.			mm in.			mm in.		
-0.006 -0.017 -0.00025 -0.00065	0.006T 0.017L 0.00025T 0.00065L	g6	-0.006 -0.017 -0.00025 -0.00065	0.006T 0.017L 0.00025T 0.00065L	g6	-0.016 -0.027 -0.0006 -0.0010	0.004L 0.027L 0.0001L 0.0010L	f6
-0.007 -0.020 -0.0003 -0.0008	0.005T 0.020L 0.0002T 0.0008L	g6	-0.007 -0.020 -0.0003 -0.0008	0.005T 0.020L 0.0002T 0.0008L	g6	-0.020 -0.033 -0.0008 -0.0013	0.008L 0.033L 0.0003L 0.0013L	f6
-0.009 -0.025 -0.0004 -0.0010	0.003T 0.025L 0.0001T 0.0010L	g6	-0.009 -0.025 -0.0004 -0.0010	0.003T 0.025L 0.0001T 0.0010L	g6	-0.025 -0.041 -0.0010 -0.0016	0.013L 0.041L 0.0005L 0.0016L	f6
-0.010 -0.029 -0.0004 -0.0011	0.005T 0.029L 0.0002T 0.0011L	g6	-0.010 -0.029 -0.0004 -0.0011	0.005T 0.029L 0.0002T 0.0011L	g6	-0.030 -0.049 -0.0012 -0.0019	0.015L 0.049L 0.0006L 0.0019L	f6
-0.012 -0.034 -0.0005 -0.0014	0.008T 0.034L 0.0003T 0.0014L	g6	-0.012 -0.034 -0.0005 -0.0014	0.008T 0.034L 0.0003T 0.0014L	g6	-0.036 -0.058 -0.0014 -0.0023	0.016L 0.058L 0.0006L 0.0023L	f6
-0.014 -0.039 -0.0006 -0.0016	0.011T 0.039L 0.0004T 0.0016L	g6	-0.014 -0.039 -0.0006 -0.0016	0.011T 0.039L 0.0004T 0.0016L	g6	-0.043 -0.068 -0.0016 -0.0026	0.018L 0.068L 0.0006L 0.0026L	f6
-0.015 -0.044 -0.0006 -0.0018	0.015T 0.044L 0.0006T 0.0018L	g6	-0.015 -0.044 -0.0006 -0.0018	0.015T 0.044L 0.0006T 0.0018L	g6	-0.050 -0.079 -0.0020 -0.0032	0.020L 0.079L 0.0008L 0.0032L	f6

Continued on next page.



Class: K and N Cones

Cone Bore		Deviation From Maximum Cone Bore And Resultant Fit									
Range (mm/in.)		Tolerance (mm/in.)	Rotating Cone			Rotating Or Stationary Cone			Stationary Cone		
			Ground Seat			Unground Seat Or Ground Seat			Unground Seat		
Over	Incl.		Constant Loads With Moderate Shock			Heavy Loads, High Speed Or Shock			Moderate Loads, No Shock		
		Cone Seat Deviation	Resultant Fit	Symbol	Cone Seat Deviation	Resultant Fit	Symbol	Cone Seat Deviation	Resultant Fit	Symbol	
		mm in.	mm in.		mm in.	mm in.		mm in.	mm in.		
250.000 9.8425	280.000 11.0236	-0.035 0.000 -0.0014 0.0000	+0.066 +0.034 +0.0026 +0.0014	0.101T 0.034T 0.0040T 0.0014T	n6	+0.146 +0.094 +0.0057 +0.0037	0.181T 0.094T 0.0071T 0.0037T	r7	0.000 -0.032 0.0000 -0.0012	0.035T 0.032L 0.0014T 0.0012L	h6
280.000 11.0236	315.000 12.4016					+0.150 +0.098 +0.0059 +0.0039	0.185T 0.098T 0.0073T 0.0039T				
315.000 12.4016	355.000 13.9764	-0.040 0.000 -0.0016 0.0000	+0.073 +0.037 +0.0030 +0.0016	0.113T 0.037T 0.0046T 0.0016T	n6	+0.165 +0.108 +0.0065 +0.0043	0.205T 0.108T 0.0081T 0.0043T	r7	0.000 -0.036 0.0000 -0.0014	0.040T 0.036L 0.0016T 0.0014L	h6
355.000 13.9764	400.000 15.7480					+0.171 +0.114 +0.0067 +0.0045	0.211T 0.114T 0.0083T 0.0045T				
400.000 15.7480	450.000 17.7165	-0.045 0.000 -0.0018 0.0000	+0.080 +0.040 +0.0034 +0.0018	0.125T 0.040T 0.0052T 0.0018T	n6	+0.189 +0.126 +0.0074 +0.0050	0.234T 0.126T 0.0092T 0.0050T	r7	0.000 -0.040 0.0000 -0.0016	0.045T 0.040L 0.0018T 0.0016L	h6
450.000 17.7165	500.000 19.6850					+0.195 +0.132 +0.0077 +0.0052	0.240T 0.132T 0.0094T 0.0052T				
500.000 19.6850	630.000 24.8032	-0.050 0.000 -0.0020 0.0000	+0.100 +0.050 +0.0039 +0.0020	0.150T 0.050T 0.0059T 0.0020T	-	+0.200 +0.125 +0.0079 +0.0050	0.250T 0.125T 0.0099T 0.0050T	-	0.000 -0.050 0.0000 -0.0020	0.050T 0.050L 0.0020T 0.0020L	-
630.000 24.8032	800.000 31.4961	-0.080 0.000 -0.0031 0.0000	+0.125 +0.050 +0.0049 +0.0020	0.205T 0.050T 0.0080T 0.0020T	-	+0.225 +0.150 +0.0089 +0.0059	0.305T 0.150T 0.0120T 0.0059T	-	0.000 -0.075 0.0000 -0.0030	0.080T 0.075L 0.0031T 0.0030L	-
800.000 31.4961	1000.000 39.3701	-0.100 0.000 -0.0039 0.0000	+0.150 +0.050 +0.0059 +0.0020	0.250T 0.050T 0.0098T 0.0020T	-	+0.275 +0.175 +0.0108 +0.0069	0.375T 0.175T 0.0147T 0.0069T	-	0.000 -0.100 0.0000 -0.0039	0.100T 0.100L 0.0039T 0.0039L	-

Deviation From Maximum Cone Bore And Resultant Fit								
Stationary Cone								
Ground Seat			Unground Seat			Hardened And Ground Seat		
Moderate Loads, No Shock			Sheaves, Wheels, Idlers			Wheel Spindles		
Cone Seat Deviation	Resultant Fit	Symbol	Cone Seat Deviation	Resultant Fit	Symbol	Cone Seat Deviation	Resultant Fit	Symbol
mm in.			mm in.			mm in.		
-0.017 -0.049 -0.0007 -0.0019	0.018T 0.049L 0.0007T 0.0019L	g6	-0.017 -0.049 -0.0007 -0.0019	0.018T 0.049L 0.0007T 0.0019L	g6	-0.056 -0.088 -0.0022 -0.0034	0.021L 0.088L 0.0008L 0.0034L	f6
-0.018 -0.075 -0.0007 -0.0029	0.022T 0.075L 0.0009T 0.0029L	g7	-0.018 -0.075 -0.0007 -0.0029	0.022T 0.075L 0.0009T 0.0029L	g7	-	-	-
-0.020 -0.083 -0.0008 -0.0033	0.025T 0.083L 0.0010T 0.0033L	g7	-0.020 -0.083 -0.0008 -0.0033	0.025T 0.083L 0.0010T 0.0033L	g7	-	-	-
-0.050 -0.100 -0.0020 -0.0039	0.000 0.100L 0.0000 0.0039L	-	-0.050 -0.100 -0.0020 -0.0039	0.000 0.100L 0.0000 0.0039L	-	-	-	-
-0.080 -0.150 -0.0031 -0.0059	0.000 0.150L 0.0000 0.0059L	-	-0.080 -0.150 -0.0031 -0.0059	0.000 0.150L 0.0000 0.0059L	-	-	-	-
-0.100 -0.200 -0.0039 -0.0079	0.000 0.200L 0.0000 0.0079L	-	-0.100 -0.200 -0.0039 -0.0079	0.000 0.200L 0.0000 0.0079L	-	-	-	-



Class: K and N Cups

Cup O.D.		Deviation From Maximum Cup O.D. And Resultant Fit												
Range (mm/in.)		Tolerance (mm/in.)	Stationary Cup									Rotating Cup		
			Floating Or Clamped			Adjustable			Nonadjustable Or In Carriers			Nonadjustable Or In Carriers Or Sheaves-clamped		
Over	Incl.		Cup Seat Deviation	Resultant Fit	Symbol	Cup Seat Deviation	Resultant Fit	Symbol	Cup Seat Deviation	Resultant Fit	Symbol	Cup Seat Deviation	Resultant Fit	Symbol
		mm in.	mm in.			mm in.			mm in.			mm in.		
18.000 0.7087	30.000 1.1811	0.000 -0.012 0.0000 -0.0005	+0.007 +0.028 +0.0003 +0.0011	0.007L 0.040L 0.0003L 0.0016L	G7	-0.009 +0.012 -0.0003 +0.0005	0.009T 0.024L 0.0003T 0.0010L	J7	-0.035 -0.014 -0.0013 -0.0005	0.035T 0.002T 0.0013T 0.0000	P7	-0.041 -0.020 -0.0017 -0.0009	0.041T 0.008T 0.0017T 0.0004T	R7
30.000 1.1811	50.000 1.9685	0.000 -0.014 0.0000 -0.0006	+0.009 +0.034 +0.0004 +0.0014	0.009L 0.048L 0.0004L 0.0020L	G7	-0.011 +0.014 -0.0004 +0.0006	0.011T 0.028L 0.0004T 0.0011L	J7	-0.042 -0.017 -0.0016 -0.0006	0.042T 0.003T 0.0016T 0.0000	P7	-0.050 -0.025 -0.0020 -0.0010	0.050T 0.011T 0.0020T 0.0004T	R7
50.000 1.9685	65.000 2.5591	0.000 -0.016 0.0000 -0.0006	+0.010 +0.040 +0.0004 +0.0016	0.010L 0.056L 0.0004L 0.0022L	G7	-0.012 +0.018 -0.0004 +0.0008	0.012T 0.034L 0.0004T 0.0014L	J7	-0.051 -0.021 -0.0021 -0.0009	0.051T 0.005T 0.0021T 0.0003T	P7	-0.060 -0.030 -0.0024 -0.0012	0.060T 0.014T 0.0024T 0.0006T	R7
65.000 2.5591	80.000 3.1496											-0.062 -0.032 -0.0024 -0.0013	0.062T 0.016T 0.0024T 0.0006T	
80.000 3.1496	100.000 3.9370	0.000 -0.018 0.0000 -0.0007	+0.012 +0.047 +0.0005 +0.0019	0.012L 0.065L 0.0005L 0.0026L	G7	-0.013 +0.022 -0.0005 +0.0009	0.013T 0.040L 0.0005T 0.0016L	J7	-0.059 -0.024 -0.0025 -0.0011	0.059T 0.006T 0.0025T 0.0004T	P7	-0.073 -0.038 -0.0029 -0.0015	0.073T 0.020T 0.0029T 0.0008T	R7
100.000 3.9370	120.000 4.7244											-0.076 -0.041 -0.0030 -0.0016	0.076T 0.023T -0.0030 -0.0009	
120.000 4.7244	150.000 5.9055	0.000 -0.020 0.0000 -0.0008	+0.014 +0.054 +0.0006 +0.0022	0.014L 0.074L 0.0006L 0.0030L	G7	-0.014 +0.026 -0.0006 +0.0010	0.014T 0.046L 0.0006T 0.0018L	J7	-0.068 -0.028 -0.0028 -0.0012	0.068T 0.008T 0.0028T 0.0004T	P7	-0.089 -0.048 -0.0035 -0.0019	0.089T 0.028T 0.0035T 0.0011T	-
150.000 5.9055	180.000 7.0866	0.000 -0.025 0.0000 -0.0010	+0.014 +0.054 +0.0006 +0.0022	0.014L 0.079L 0.0006L 0.0032L	G7	-0.014 +0.026 -0.0006 +0.0010	0.014T 0.051L 0.0006T 0.0020L	J7	-0.068 -0.028 -0.0028 -0.0012	0.068T 0.008T 0.0028T 0.0002T	P7	-0.089 -0.048 -0.0035 -0.0019	0.089T 0.023T 0.0035T 0.0009T	-
180.000 7.0866	200.000 7.8740	0.000 -0.030 0.0000 -0.0012	+0.015 +0.061 +0.0006 +0.0024	0.015L 0.091L 0.0006L 0.0036L	G7	-0.016 +0.030 -0.0007 +0.0011	0.016T 0.060L 0.0007T 0.0023L	J7	-0.079 -0.033 -0.0032 -0.0014	0.079T 0.003T 0.0032T 0.0002T	P7	-0.106 -0.060 -0.0042 -0.0024	0.106T 0.030T 0.0042T 0.0012T	R7
200.000 7.8740	225.000 8.8583											-0.109 -0.063 -0.0043 -0.0025	0.109T 0.033T 0.0043T 0.0013T	
225.000 8.8583	250.000 9.8425											-0.113 -0.067 -0.0044 -0.0026	0.113T 0.037T 0.0044T 0.0015T	

Continued on next page.

Cup O.D.		Deviation From Maximum Cup O.D. And Resultant Fit												
Range (mm/in.)		Tolerance (mm/in.)	Stationary Cup									Rotating Cup		
			Floating Or Clamped			Adjustable			Nonadjustable Or In Carriers			Nonadjustable Or In Carriers Or Sheaves-clamped		
Over	Incl.		Cup Seat Deviation	Resultant Fit	Symbol	Cup Seat Deviation	Resultant Fit	Symbol	Cup Seat Deviation	Resultant Fit	Symbol	Cup Seat Deviation	Resultant Fit	Symbol
		mm in.	mm in.			mm in.			mm in.			mm in.		
250.000 9.8425	280.000 11.0236	0.000 -0.035 0.0000 -0.0014	+0.017 +0.069 +0.0007 +0.0027	0.017L 0.104L 0.0007L 0.0041L	G7	-0.016 +0.036 -0.0007 +0.0013	0.016T 0.071L 0.0007T 0.0027L	J7	-0.088 -0.036 -0.0034 -0.0014	0.088T 0.001T 0.0034T 0.0000	P7	-0.126 -0.074 -0.0050 -0.0029	0.126T 0.039T 0.0050T 0.0015T	R7
280.000 11.0236	315.000 12.4016											-0.130 -0.078 -0.0051 -0.0031	0.130T 0.043T 0.0051T 0.0017T	
315.000 12.4016	355.000 13.9764	0.000 -0.040 0.0000 -0.0016	+0.062 +0.098 +0.0025 +0.0039	0.062L 0.138L 0.0025L 0.0055L	F6	-0.018 +0.039 -0.0007 +0.0015	0.018T 0.079L 0.0007T 0.0031L	J7	-0.098 -0.041 -0.0039 -0.0017	0.098T 0.001T 0.0039T 0.0001T	P7	-0.144 -0.087 -0.0057 -0.0034	0.144T 0.047T 0.0057T 0.0019T	R7
355.000 13.9764	400.000 15.7480											-0.150 -0.093 -0.0059 -0.0037	0.150T 0.053T 0.0059T 0.0021T	
400.000 15.7480	450.000 17.7165	0.000 -0.045 0.0000 -0.0018	+0.068 +0.095 +0.0028 +0.0038	0.068L 0.140L 0.0028L 0.0056L	F5	-0.020 +0.043 -0.0009 +0.0016	0.020T 0.088L 0.0009T 0.0034L	J7	-0.108 -0.045 -0.0044 -0.0019	0.108T 0.000T 0.0044T 0.0001T	P7	-0.166 -0.103 -0.0065 -0.0041	0.166T 0.058T 0.0065T 0.0023T	R7
450.000 17.7165	500.000 19.6850											-0.172 -0.109 -0.0068 -0.0043	0.172T 0.064T 0.0068T 0.0025T	
500.000 19.6850	630.000 24.8032	0.000 -0.050 0.0000 -0.0020	+0.065 +0.115 +0.0026 +0.0045	0.065L 0.165L 0.0026L 0.0065L	-	-0.022 +0.046 -0.0009 +0.0018	0.022T 0.096L 0.0009T 0.0038L	-	-0.118 -0.050 -0.0046 -0.0020	0.118T 0.000T 0.0046T 0.0000	-	-0.190 -0.120 -0.0070 -0.0042	0.190T 0.070T 0.0070T 0.0022T	-
630.000 24.8032	800.000 31.4961	0.000 -0.080 0.0000 -0.0031	+0.075 +0.150 +0.0030 +0.0059	0.075L 0.230L 0.0030L 0.0090L	-	-0.025 +0.050 -0.0010 +0.0020	0.025T 0.130L 0.0010T 0.0051L	-	-0.150 -0.075 -0.0059 -0.0030	0.150T 0.005L 0.0059T 0.0001L	-	-	-	-
800.000 31.4961	1000.000 39.3701	0.000 -0.100 0.0000 -0.0039	+0.075 +0.175 +0.0030 +0.0069	0.075L 0.275L 0.0030L 0.0108L	-	-0.025 +0.075 -0.0010 +0.0030	0.025T 0.175L 0.0010T 0.0069L	-	-0.200 -0.100 -0.0079 -0.0039	0.200T 0.000T 0.0079T 0.0000	-	-	-	-



Class: C Cones

Cone Bore		Deviation From Maximum Cone Bore And Resultant Fit									
Range (mm/in.)		Tolerance (mm/in.)	Rotating Cone						Stationary Cone		
			Ground Seat			Ground Seat			Ground Seat		
Precision Machine Tool Spindles			Heavy Loads, Or High Speed Or Shock			Precision Machine Tool Spindles					
Over	Incl.		Cone Seat Deviation	Resultant Fit	Symbol	Cone Seat Deviation	Resultant Fit	Symbol	Cone Seat Deviation	Resultant Fit	Symbol
		mm in.	mm in.			mm in.			mm in.		
10.000 0.3937	18.000 0.7087	-0.007 0.000 -0.0003 0.0000	+0.009 +0.001 +0.0004 +0.0001	0.016T 0.001T 0.0007T 0.0001T	k5	+0.018 +0.007 +0.0007 +0.0003	0.025T 0.007T 0.0010T 0.0003T	m6	+0.009 +0.001 +0.0004 +0.0001	0.016T 0.001T 0.0007T 0.0001T	k5
18.000 0.7087	30.000 1.1811	-0.008 0.000 -0.0003 0.0000	+0.011 +0.002 +0.0005 +0.0001	0.019T 0.002T 0.0008T 0.0001T	k5	+0.017 +0.008 +0.0007 +0.0003	0.025T 0.008T 0.0010T 0.0003T	m5	+0.011 +0.002 +0.0005 +0.0001	0.019T 0.002T 0.0008T 0.0001T	k5
30.000 1.1811	50.000 1.9685	-0.010 0.000 -0.0004 0.0000	+0.013 +0.002 +0.0005 +0.0001	0.023T 0.002T 0.0009T 0.0001T	k5	+0.020 +0.009 +0.0008 +0.0004	0.030T 0.009T 0.0012T 0.0004T	m5	+0.013 +0.002 +0.0005 +0.0001	0.023T 0.002T 0.0009T 0.0001T	k5
50.000 1.9685	80.000 3.1496	-0.012 0.000 -0.0005 0.0000	+0.015 +0.002 +0.0006 +0.0001	0.027T 0.002T 0.0011T 0.0001T	k5	+0.033 +0.020 +0.0013 +0.0008	0.045T 0.020T 0.0018T 0.0008T	n5	+0.015 +0.002 +0.0006 +0.0001	0.027T 0.002T 0.0011T 0.0001T	k5
80.000 3.1496	120.000 4.7244	-0.015 0.000 -0.0006 0.0000	+0.018 +0.003 +0.0007 +0.0001	0.033T 0.003T 0.0013T 0.0001T	k5	+0.038 +0.023 +0.0016 +0.0010	0.053T 0.023T 0.0022T 0.0010T	n5	+0.018 +0.003 +0.0007 +0.0001	0.033T 0.003T 0.0013T 0.0001T	k5
120.000 4.7244	180.000 7.0866	-0.018 0.000 -0.0007 0.0000	+0.021 +0.003 +0.0008 +0.0001	0.039T 0.003T 0.0015T 0.0001T	k5	+0.055 +0.043 +0.0023 +0.0018	0.073T 0.043T 0.0030T 0.0018T	p4	+0.021 +0.003 +0.0008 +0.0001	0.039T 0.003T 0.0015T 0.0001T	k5
180.000 7.0866	200.000 7.8740					+0.091 +0.077 +0.0036 +0.0030	0.113T 0.077T +0.0044 +0.0030				
200.000 7.8740	225.000 8.8583	-0.022 0.000 -0.0009 0.0000	+0.024 +0.004 +0.0010 +0.0002	0.046T 0.004T 0.0019T 0.0002T	k5	+0.094 +0.080 +0.0037 +0.0031	0.116T 0.080T +0.0046 +0.0031	r4	+0.024 +0.004 +0.0010 +0.0002	0.046T 0.004T 0.0019T 0.0002T	k5
225.000 8.8583	250.000 9.8425					+0.098 +0.084 +0.0039 +0.0033	0.120T 0.084T +0.0047 +0.0033				

Continued on next page.

Cone Bore		Deviation From Maximum Cone Bore And Resultant Fit									
Range (mm/in.)		Tolerance (mm/in.)	Rotating Cone						Stationary Cone		
			Ground Seat			Ground Seat			Ground Seat		
Precision Machine Tool Spindles			Heavy Loads, Or High Speed Or Shock			Precision Machine Tool Spindles					
Over	Incl.		Cone Seat Deviation	Resultant Fit	Symbol	Cone Seat Deviation	Resultant Fit	Symbol	Cone Seat Deviation	Resultant Fit	Symbol
		mm in.	mm in.			mm in.			mm in.		
250.000 9.8425	280.000 11.0236	-0.022 0.000 -0.0009 0.0000	+0.027 +0.004 +0.0011 +0.0002	0.049T 0.004T 0.0020T 0.0002T	k5	-0.126 -0.074 -0.0050 -0.0029	0.126T 0.039T 0.0050T 0.0015T	r5	+0.027 +0.004 +0.0011 +0.0002	0.049T 0.004T 0.0020T 0.0002T	k5
280.000 11.0236	315.000 12.4016		-0.130 -0.078 -0.0051 -0.0031	0.130T 0.043T 0.0051T 0.0017T							
315.000 12.4016	355.000 13.9764	-0.025 0.000 -0.0010 0.0000	+0.029 +0.004 +0.0012 +0.0002	0.054T 0.004T 0.0022T 0.0002T	k5	-0.144 -0.087 -0.0057 -0.0034	0.144T 0.047T 0.0057T 0.0019T	r5	+0.029 +0.004 +0.0012 +0.0002	0.054T 0.004T 0.0022T 0.0002T	k5
355.000 13.9764	400.000 15.7480		-0.150 -0.093 -0.0059 -0.0037	0.150T 0.053T 0.0059T 0.0021T							
400.000 15.7480	450.000 17.7165	-0.025 0.000 -0.0010 0.0000	+0.032 +0.005 +0.0012 +0.0002	0.057T 0.005T 0.0022T 0.0002T	k5	-0.166 -0.103 -0.0065 -0.0041	0.166T 0.058T 0.0065T 0.0023T	r5	+0.032 +0.005 +0.0012 +0.0002	0.057T 0.005T 0.0022T 0.0002T	k5
450.000 17.7165	500.000 19.6850		-0.172 -0.109 -0.0068 -0.0043	0.172T 0.064T 0.0068T 0.0025T							
500.000 19.6850	630.000 24.8032	-0.030 0.000 -0.0012 0.0000	+0.040 +0.010 +0.0016 +0.0004	0.070T 0.010T 0.0028T 0.0004T	-	+0.185 +0.150 +0.0073 +0.0059	0.216T 0.150T 0.0085T 0.0059T	-	+0.040 +0.010 +0.0016 +0.0004	0.070T 0.010T 0.0028T 0.0004T	-
630.000 24.8032	800.000 31.4961	-0.040 0.000 -0.0016 0.0000	+0.055 +0.015 +0.0022 +0.0006	0.095T 0.015T 0.0038T 0.0006T	-	+0.220 +0.175 +0.0087 +0.0069	0.260T 0.175T 0.0103T 0.0069T	-	+0.055 +0.015 +0.0022 +0.0006	0.095T 0.015T 0.0038T 0.0006T	-
800.000 31.4961	1000.000 39.3701	-0.050 0.000 -0.0020 0.0000	+0.065 +0.015 +0.0026 +0.0006	0.115T 0.015T 0.0046T 0.0006T	-	+0.255 +0.200 +0.0100 +0.0079	0.305T 0.200T 0.0120T 0.0079T	-	+0.065 +0.015 +0.0026 +0.0006	0.115T 0.015T 0.0046T 0.0006T	-



Class: C Cups

Cup O.D.		Deviation From Maximum Cup O.D. And Resultant Fit															
Range (mm/in.)		Tolerance (mm/in.)	Stationary Cup												Rotating Cup		
			Floating			Clamped			Adjustable			Nonadjustable Or In Carriers			Nonadjustable Or In Carriers		
Over	Incl.		Cup Seat Deviation	Resultant Fit	Symbol	Cup Seat Deviation	Resultant Fit	Symbol	Cup Seat Deviation	Resultant Fit	Symbol	Cup Seat Deviation	Resultant Fit	Symbol	Cup Seat Deviation	Resultant Fit	Symbol
		mm in.	mm in.	mm in.		mm in.	mm in.		mm in.	mm in.		mm in.	mm in.		mm in.	mm in.	
18.000 0.7087	30.000 1.1811	0.000 -0.008 0.0000 -0.0003	+0.007 +0.016 +0.0003 +0.0007	0.007L 0.024L 0.0003L 0.0010L	G5	0.000 +0.009 0.0000 +0.0004	0.000 0.017L 0.0000 0.0007L	H5	-0.008 +0.001 -0.0004 0.0000	0.008T 0.009L 0.0004T 0.0003L	K5	-0.021 -0.012 -0.00085 -0.00045	0.021T 0.004T 0.00085T 0.00015T	N5	-0.024 -0.011 -0.0010 -0.0005	0.024T 0.003T 0.0010T 0.0002T	N6
30.000 1.1811	50.000 1.9685	0.000 -0.009 0.0000 -0.0004	+0.009 +0.020 +0.0004 +0.0008	0.009L 0.0290L 0.0004L 0.0012L	G5	0.000 +0.011 0.0000 +0.0004	0.000 0.020L 0.0000 0.0008L	H5	-0.009 +0.002 -0.0004 0.0000	0.009T 0.011L 0.0004T 0.0004L	K5	-0.024 -0.013 -0.0010 -0.0006	0.024T 0.004T 0.0010T 0.0002T	N5	-0.028 -0.012 -0.0011 -0.0005	0.028T 0.003T 0.0011T 0.0001T	N6
50.000 1.9685	80.000 3.1496	0.000 -0.011 0.0000 -0.0004	+0.010 +0.023 +0.0004 +0.0009	0.010L 0.034L 0.0004L 0.0013L	G5	0.000 +0.013 0.0000 +0.0005	0.000 0.024L 0.0000 0.0009L	H5	-0.010 +0.003 -0.0004 +0.0001	0.010T 0.014L 0.0004T 0.0005L	K5	-0.028 -0.015 -0.0011 -0.0006	0.028T 0.004T 0.0011T 0.0002T	N5	-0.033 -0.014 -0.0013 -0.0006	0.033T 0.003T 0.0013T 0.0002T	N6
80.000 3.1496	120.000 4.7244	0.000 -0.013 0.0000 -0.0005	+0.012 +0.027 +0.0005 +0.0011	0.012L 0.040L 0.0005L 0.0016L	G5	0.000 +0.015 0.0000 +0.0006	0.000 0.028L 0.0000 0.0011L	H5	-0.013 +0.002 -0.0005 +0.0001	0.013T 0.015L 0.0005T 0.0006L	K5	-0.033 -0.018 -0.0014 -0.0008	0.033T 0.005T 0.0014T 0.0003T	N5	-0.038 -0.016 -0.0016 -0.0007	0.038T 0.003T 0.0016T 0.0002T	N6
120.000 4.7244	150.000 5.9055	0.000 -0.015 0.0000 -0.0006	+0.014 +0.032 +0.0006 +0.0013	0.014L 0.047L 0.0006L 0.0019L	G5	0.000 +0.018 0.0000 +0.0007	0.000 0.033L 0.0000 0.0013L	H5	-0.013 +0.013 -0.0005 +0.0005	0.013T 0.028L 0.0005T 0.0011L	J6	-0.039 -0.021 -0.0017 -0.0010	0.039T 0.006T 0.0017T 0.0004T	N5	-0.045 -0.020 -0.0019 -0.0009	0.045T 0.005T 0.0019T 0.0003T	N6
150.000 5.9055	180.000 7.0866	0.000 -0.018 0.0000 -0.0007	+0.014 +0.032 +0.0006 +0.0013	0.014L 0.050L 0.0006L 0.0020L	G5	0.000 +0.018 0.0000 +0.0007	0.000 0.036L 0.0000 0.0014L	H5	-0.013 +0.013 -0.0005 +0.0005	0.013T 0.031L 0.0005T 0.0012L	J6	-0.039 -0.021 -0.0017 -0.0010	0.039T 0.003T 0.0017T 0.0003T	N5	-0.045 -0.020 -0.0019 -0.0009	0.045T 0.002T 0.0019T 0.0002T	N6
180.000 7.0866	250.000 9.8425	0.000 -0.020 0.0000 -0.0008	+0.015 +0.035 +0.0006 +0.0014	0.015L 0.055L 0.0006L 0.0022L	G5	0.000 +0.020 0.0000 +0.0008	0.000 0.040L 0.0000 0.0016L	H5	-0.015 +0.015 -0.0006 +0.0006	0.015T 0.035L 0.0006T 0.0014L	J6	-0.045 -0.025 -0.0020 -0.0012	0.045T 0.005T 0.0020T 0.0004T	N5	-0.051 -0.022 -0.0022 -0.0010	0.051T 0.002T 0.0022T 0.0002T	N6
250.000 9.8425	315.000 12.4016	0.000 -0.025 0.0000 -0.0010	+0.017 +0.040 +0.0007 +0.0016	0.017L 0.065L 0.0007L 0.0026L	G5	0.000 +0.023 0.0000 +0.0009	0.000 0.048L 0.0000 0.0019L	H5	-0.020 +0.003 -0.0008 +0.0001	0.020T 0.028L 0.0008T 0.0011L	K5	-0.050 -0.027 -0.0020 -0.0011	0.050T 0.002T 0.0020T 0.0001T	N5	-0.050 -0.027 -0.0020 -0.0011	0.050T 0.002T 0.0020T 0.0001T	N5

Continued on next page.

Cup O.D.		Deviation From Maximum Cup O.D. And Resultant Fit															
Range (mm/in.)		Tolerance (mm/in.)	Stationary Cup												Rotating Cup		
			Floating			Clamped			Adjustable			Nonadjustable Or In Carriers			Nonadjustable Or In Carriers		
Over	Incl.		Cup Seat Deviation	Resultant Fit	Symbol	Cup Seat Deviation	Resultant Fit	Symbol	Cup Seat Deviation	Resultant Fit	Symbol	Cup Seat Deviation	Resultant Fit	Symbol	Cup Seat Deviation	Resultant Fit	Symbol
		mm in.	mm in.			mm in.			mm in.			mm in.			mm in.		
315.000 12.4016	400.000 15.7480	0.000 -0.028 0.0000 -0.0011	+0.018 +0.043 +0.0007 +0.0017	0.018L 0.071L 0.0007L 0.0028L	G5	0.000 +0.025 0.0000 +0.0010	0.000 0.053L 0.0000 0.0021L	H5	-0.022 +0.003 -0.0009 +0.0001	0.022T 0.0031L 0.0009T 0.0012L	K5	-0.055 -0.030 -0.0023 -0.0013	0.055T 0.002T 0.0023T 0.0002T	N5	-0.055 -0.030 -0.0023 -0.0013	0.055T 0.002T 0.0023T 0.0002T	N5
400.000 15.7480	500.000 19.6850	0.000 -0.030 0.0000 -0.0012	+0.020 +0.047 +0.0008 +0.0018	0.020L 0.077L 0.0008L 0.0030L	G5	0.000 +0.025 0.0000 +0.0010	0.000 0.057L 0.0000 0.0022L	H5	-0.025 +0.002 -0.0010 0.0000	0.025T 0.032L 0.0010T 0.0012L	K5	-0.060 -0.033 -0.0026 -0.0016	0.060T 0.003T 0.0026T 0.0004T	N5	-0.060 -0.033 -0.0026 -0.0016	0.060T 0.003T 0.0026T 0.0004T	N5
500.000 19.6850	630.000 24.8032	0.000 -0.035 0.0000 -0.0014	+0.025 +0.050 +0.0010 +0.0020	0.025L 0.085L 0.0010L 0.0034L	-	0.000 +0.025 0.0000 +0.0010	0.000 0.060L 0.0000 0.0024L	-	-0.025 0.000 -0.0010 0.0000	0.025T 0.035L 0.0010T 0.0014L	-	-0.065 -0.040 -0.0026 -0.0016	0.065T 0.005T 0.0026T 0.0002T	-	-0.075 -0.038 -0.0030 -0.0015	0.075T 0.003T 0.0030T 0.0001T	-
630.000 24.8032	800.000 31.4961	0.000 -0.040 0.0000 -0.0016	+0.025 +0.065 +0.0010 +0.0026	0.025L 0.105L 0.0010L 0.0042L	-	0.000 +0.041 0.0000 +0.0016	0.000 0.080L 0.0000 0.0032L	-	-0.040 0.000 -0.0016 0.0000	0.040T 0.040L 0.0016T 0.0016L	-	-0.090 -0.050 -0.0035 -0.0020	0.090T 0.010T 0.0035T 0.0004T	-	-0.095 -0.050 -0.0037 -0.0020	0.095T 0.010T 0.0037T 0.0006T	-
800.000 31.4961	1000.000 39.3701	0.000 -0.050 0.0000 -0.0020	+0.025 +0.075 +0.0010 +0.0030	0.025L 0.125L 0.0010L 0.0050L	-	0.000 +0.051 0.0000 +0.0020	0.000 0.100L 0.0000 0.0040L	-	-0.050 0.000 -0.0020 0.0000	0.050T 0.050L 0.0020T 0.0020L	-	-0.100 -0.050 -0.0039 -0.0020	0.100T 0.000 0.0039T 0.0000	-	-0.115 0.065 -0.0045 -0.0026	0.115T 0.015T 0.0045T 0.0006T	-



Class: B Cones

Cone Bore		Deviation From Maximum Cone Bore And Resultant Fit									
Range (mm/in.)		Tolerance (mm/in.)	Rotating Cone						Stationary Cone		
			Ground Seat			Ground Seat			Ground Seat		
Over	Incl.		Precision Machine Tool Spindles			Heavy Loads, Or High Speed Or Shock			Precision Machine Tool Spindles		
		Cone Seat Deviation	Resultant Fit	Symbol	Cone Seat Deviation	Resultant Fit	Symbol	Cone Seat Deviation	Resultant Fit	Symbol	
		mm in.	mm in.			mm in.			mm in.		
10.000 0.3937	18.000 0.7087	-0.005 0.000 -0.0002 0.0000	+0.009 +0.001 +0.0004 +0.0001	0.014T 0.001T 0.0006T 0.0001T	k5	+0.015 +0.007 +0.0006 +0.0003	0.020T 0.007T 0.0008T 0.0003T	m5	+0.009 +0.001 +0.0004 +0.0001	0.014T 0.001T 0.0006T 0.0001T	k5
18.000 0.7087	30.000 1.1811	-0.006 0.000 -0.0002 0.0000	+0.011 +0.002 +0.0005 +0.0001	0.017T 0.002T 0.0007T 0.0001T	k5	+0.017 +0.008 +0.0007 +0.0003	0.023T 0.008T 0.0009T 0.0003T	m5	+0.011 +0.002 +0.0005 +0.0001	0.017T 0.002T 0.0007T 0.0001T	k5
30.000 1.1811	50.000 1.9685	-0.008 0.000 -0.0003 0.0000	+0.013 +0.002 +0.0005 +0.0001	0.021T 0.002T 0.0008T 0.0001T	k5	+0.020 +0.009 +0.0008 +0.0004	0.028T 0.009T 0.0011T 0.0004T	m5	+0.013 +0.002 +0.0005 +0.0001	0.021T 0.002T 0.0008T 0.0001T	k5
50.000 1.9685	80.000 3.1496	-0.009 0.000 -0.0004 0.0000	+0.015 +0.002 +0.0006 +0.0001	0.024T 0.002T 0.0010T 0.0001T	k5	+0.033 +0.020 +0.0013 +0.0008	0.042T 0.020T 0.0017T 0.0008T	n5	+0.015 +0.002 +0.0006 +0.0001	0.024T 0.002T 0.0010T 0.0001T	k5
80.000 3.1496	120.000 4.7244	-0.010 0.000 -0.0004 0.0000	+0.018 +0.003 +0.0007 +0.0001	0.028T 0.003T 0.0011T 0.0001T	k5	+0.033 +0.023 +0.0014 +0.0010	0.043T 0.023T 0.0018T 0.0010T	n4	+0.018 +0.003 +0.0007 +0.0001	0.028T 0.003T 0.0011T 0.0001T	k5
120.000 4.7244	180.000 7.0866	-0.013 0.000 -0.0005 0.0000	+0.021 +0.003 +0.0008 +0.0001	0.034T 0.003T 0.0013T 0.0001T	k5	+0.055 +0.043 +0.0023 +0.0018	0.068T 0.043T 0.0028T 0.0018T	p4	+0.021 +0.003 +0.0008 +0.0001	0.034T 0.003T 0.0013T 0.0001T	k5
180.000 7.0866	200.000 7.8740	-0.015 0.000 -0.0006 0.0000	+0.024 +0.004 +0.0010 +0.0002	0.039T 0.004T 0.0016T 0.0002T	k5	+0.091 +0.077 +0.0036 +0.0030	0.113T 0.077T +0.0044 +0.0030	r4	+0.024 +0.004 +0.0010 +0.0002	0.039T 0.004T 0.0016T 0.0002T	k5
200.000 7.8740	225.000 8.8583					+0.094 +0.080 +0.0037 +0.0031	0.116T 0.084T +0.0046 +0.0031				
225.000 8.8583	250.000 9.8425					+0.098 +0.084 +0.0039 +0.0033	0.120T 0.084T +0.0047 +0.0033				
250.000 9.8425	280.000 11.0236	-0.018 0.000 -0.0007 0.0000	+0.027 +0.004 +0.0011 +0.0002	0.045T 0.004T 0.0018T 0.0002T	k5	-0.126 -0.074 -0.0050 -0.0029	0.126T 0.039T 0.0050T 0.0015T	r4	+0.027 +0.004 +0.0011 +0.0002	0.045T 0.004T 0.0018T 0.0002T	k5
280.000 11.0236	315.000 12.4016					-0.130 -0.078 -0.0051 -0.0031	0.130T 0.043T 0.0051T 0.0017T				



Class: B Cups

Cup O.D.		Deviation From Maximum Cup O.D. And Resultant Fit															
Range (mm/in.)		Tolerance (mm/in.)	Stationary Cup									Stationary Cup			Rotating Cup		
			Floating			Clamped			Adjustable			Nonadjustable Or In Carriers			Nonadjustable Or In Carriers		
Over	Incl.		Cup Seat Deviation	Resultant Fit	Symbol	Cup Seat Deviation	Resultant Fit	Symbol	Cup Seat Deviation	Resultant Fit	Symbol	Cup Seat Deviation	Resultant Fit	Symbol	Cup Seat Deviation	Resultant Fit	Symbol
		mm in.	mm in.			mm in.			mm in.			mm in.			mm in.		
18.000 0.7087	30.000 1.1811	0.000 -0.006 0.0000 -0.0002	+0.007 +0.016 +0.0003 +0.0007	0.007L 0.022L 0.0003L 0.0009L	G5	0.000 +0.006 0.0000 +0.00025	0.0000 0.012L 0.0000 0.00045L	H4	-0.008 0.001 -0.0004 0.0000	0.008T 0.007L 0.0004T 0.0002L	K5	-0.0140 -0.0050 -0.00055 -0.00015	0.0140T 0.0013L 0.00055T 0.00005L	M5	-0.021 -0.012 -0.00085 -0.00045	0.021T 0.006T 0.00085T 0.00025T	N5
30.000 1.1811	50.000 1.9685	0.000 -0.007 0.0000 -0.0003	+0.009 +0.020 +0.0004 +0.0008	0.009L 0.027L 0.0004L 0.0011L	G5	0.000 +0.007 0.0000 +0.0003	0.000 0.014L 0.0000 0.0006L	H4	-0.009 0.002 -0.0004 0.0000	0.009T 0.007L 0.0004T 0.0003L	K5	-0.016 -0.005 -0.0007 -0.0003	0.016T 0.002L 0.0007T 0.0000	M5	-0.024 -0.013 -0.0010 -0.0006	0.024T 0.006T 0.0010T 0.0003T	N5
50.000 1.9685	80.000 3.1496	0.000 -0.009 0.0000 -0.0004	+0.010 +0.023 +0.0004 +0.0009	0.010L 0.032L 0.0004L 0.0013L	G5	0.000 +0.008 0.0000 +0.0003	0.000 0.017L 0.0000 0.0007L	H4	-0.010 +0.003 -0.0004 +0.0001	0.010T 0.012L 0.0004T 0.0005L	K5	-0.019 -0.006 -0.0008 -0.0003	0.019T 0.003L 0.0008T 0.0001L	M5	-0.028 -0.015 -0.0011 -0.0006	0.028T 0.006T 0.0011T 0.0002T	N5
80.000 3.1496	120.000 4.7244	0.000 -0.010 0.0000 -0.0004	+0.012 +0.027 +0.0005 +0.0011	0.012L 0.037L 0.0005L 0.0015L	G5	0.000 +0.010 0.0000 +0.0004	0.000 0.020L 0.0000 0.0008L	H4	-0.013 +0.002 -0.0005 +0.0001	0.013T 0.012L 0.0005T 0.0005L	K5	-0.023 -0.008 -0.0009 -0.0003	0.023T 0.002L 0.0009T 0.0001L	M5	-0.033 -0.018 -0.0014 -0.0008	0.033T 0.008T 0.0014T 0.0004T	N5
120.000 4.7244	150.000 5.9055	0.000 -0.011 0.0000 -0.0004	+0.014 +0.032 +0.0006 +0.0013	0.014L 0.043L 0.0006L 0.0017L	G5	0.000 +0.012 0.0000 +0.0005	0.000 0.023L 0.0000 0.0009L	H4	-0.013 +0.013 -0.0005 +0.0005	0.013T 0.024L 0.0005T 0.0009L	Js6	-0.027 -0.009 -0.0011 -0.0004	0.027T 0.002L 0.0011T 0.0000	M5	-0.039 -0.021 -0.0017 -0.0010	0.039T 0.010T 0.0017T 0.0006T	N5
150.000 5.9055	180.000 7.0866	0.000 -0.013 0.0000 -0.0005	+0.014 +0.032 +0.0006 +0.0013	0.014L 0.045L 0.0006L 0.0018L	G5	0.000 +0.012 0.0000 +0.0005	0.000 0.025L 0.0000 0.0010L	H4	-0.013 +0.013 -0.0005 +0.0005	0.013T 0.026L 0.0005T 0.0010L	Js6	-0.027 -0.009 -0.0011 -0.0004	0.027T 0.004L 0.0011T 0.0001L	M5	-0.039 -0.021 -0.0017 -0.0010	0.039T 0.008T 0.0017T 0.0005T	N5
180.000 7.0866	250.000 9.8425	0.000 -0.015 0.0000 -0.0006	+0.015 +0.035 +0.0006 +0.0014	0.015L 0.050L 0.0006L 0.0020L	G5	0.000 +0.014 0.0000 +0.0006	0.000 0.029L 0.0000 0.0012L	H4	-0.010 +0.010 -0.0004 +0.0004	0.010T 0.025L 0.0004T 0.0010L	Js5	-0.031 -0.011 -0.0012 -0.0004	0.031T 0.004L 0.0012T 0.0002L	M5	-0.045 -0.025 -0.0020 -0.0012	0.045T 0.010T 0.0020T 0.0006T	N5
250.000 9.8425	315.000 12.4016	0.000 -0.018 0.0000 -0.0007	+0.017 +0.040 +0.0007 +0.0016	0.017L 0.058L 0.0007L 0.0023L	G5	0.000 +0.016 0.0000 +0.0006	0.000 0.034L 0.0000 0.0013L	H4	-0.012 +0.012 -0.0004 +0.0004	0.012T 0.030L 0.0004T 0.0011L	Js5	-0.036 -0.013 -0.0014 -0.0005	0.036L 0.005L 0.0014T 0.0002L	M5	-0.050 -0.027 -0.0020 -0.0011	0.050T 0.009T 0.0020T 0.0004T	N5



Class: A and AA Cones

Cone Bore		Deviation From Maximum Cone Bore And Resultant Fit									
Range (mm/in.)		Tolerance (mm/in.)	Rotating Cone						Stationary Cone		
			Ground Seat			Ground Seat			Ground Seat		
Precision Machine Tool Spindles			Heavy Loads, Or High Speed Or Shock			Precision Machine Tool Spindles					
Over	Incl.		Cone Seat Deviation	Resultant Fit	Symbol	Cone Seat Deviation	Resultant Fit	Symbol	Cone Seat Deviation	Resultant Fit	Symbol
		mm in.	mm in.			mm in.			mm in.		
10.000 0.3937	18.000 0.7087	-0.005 0.000 -0.0002 0.0000	+0.013 +0.005 +0.0005 +0.0002	0.018T 0.005T 0.0007T 0.0002T	-	-	-	-	+0.013 +0.005 +0.0005 +0.0002	0.018T 0.005T 0.0007T 0.0002T	-
18.000 0.7087	30.000 1.1811	-0.006 0.000 -0.0002 0.0000	+0.013 +0.005 +0.0005 +0.0002	0.019T 0.005T 0.0007T 0.0002T	-	-	-	-	+0.013 +0.005 +0.0005 +0.0002	0.019T 0.005T 0.0007T 0.0002T	-
30.000 1.1811	315.000 12.4016	-0.008 0.000 -0.0003 0.0000	+0.013 +0.005 +0.0005 +0.0002	0.021T 0.005T 0.0008T 0.0002T	-	-	-	-	+0.013 +0.005 +0.0005 +0.0002	0.021T 0.005T 0.0008T 0.0002T	-

F

Class: A and AA Cups

Cup O.D.		Deviation From Maximum Cup O.D. And Resultant Fit															
Range (mm/in.)		Tolerance (mm/in.)	Stationary Cup									Stationary Cup			Rotating Cup		
			Floating			Clamped			Adjustable			Nonadjustable Or In Carriers			Nonadjustable Or In Carriers		
Over	Incl.		Cup Seat Deviation	Resultant Fit	Symbol	Cup Seat Deviation	Resultant Fit	Symbol	Cup Seat Deviation	Resultant Fit	Symbol	Cup Seat Deviation	Resultant Fit	Symbol	Cup Seat Deviation	Resultant Fit	Symbol
		mm in.	mm in.			mm in.			mm in.			mm in.			mm in.		
0.000 0.0000	315.000 12.4016	0.000 -0.008 0.0000 -0.0003	+0.008 +0.016 +0.0003 +0.0006	0.008L 0.024L 0.0003L 0.0009L	-	0.000 +0.008 0.0000 +0.0003	0.000 0.016L 0.0000 0.0006L	-	-0.008 0.000 -0.0003 0.0000	0.008T 0.008L 0.0003T 0.0003L	-	-0.016 -0.008 -0.0006 -0.0003	0.016T 0.000 0.0006T 0.0000	-	-0.024 -0.016 -0.0009 -0.0006	0.024T 0.008T 0.0009T 0.0003T	-





SPHERICAL ROLLER BEARINGS

G

G SPHERICAL ROLLER BEARINGS

Spherical Roller Bearings.....	91
Storage And Handling.....	92
s4 Fits.....	94
Mounting Procedures.....	94
SAF Pillow Block Assemblies.....	97

G

SPHERICAL ROLLER BEARINGS

G

G

SPHERICAL ROLLER BEARINGS

Timken® spherical roller bearings are designed to manage high radial loads even when misalignment, poor lubrication, contamination, extreme speeds or critical application stresses are present. Spherical bearings consist of an inner ring, outer ring, cage and center-rounded rollers. Types include:

- **Type YM** (precision-machined, roller-riding one piece brass cage): Ideal for extreme operating environments.
- **Type YMB** (precision-machined, land-riding one piece brass cage): Ideal for extreme operating environments.
- **Type YMD** (precision-machined, land-riding and two-pieced brass cages): Ideal for severe conditions.
- **Type CJ** (two-piece steel cage, window type): Suitable for a broad range of general service applications.
- **Type VCSJ** (stamped steel finger type): Suitable for general use.

Sizes: 25 mm bore and larger

Applications: Industrial applications for pulp and paper, power generation, oilfield, mining, aggregate, wind turbines, gear drives and rolling mills.

Customer Benefits: High load capacity even under misalignment conditions extends bearing life. Unit design simplifies bearing handling, installation and maintenance.



STORAGE AND HANDLING

See the General Bearing Handling and Inspection Section of this manual for guidelines regarding how to handle bearings.

New Timken bearings are normally distributed in packaging that provides necessary protection against dirt and moisture. There is no need to wash new bearings because the rust preventive on the bearing is compatible with normal lubricants. To prevent bearing contamination, do not remove the bearing from its packaging until ready for installation, and do not leave open bearings lying on the floor or workbench.

Even relatively minor mishandling or dropping the bearing can create damage that will result in significantly shorter bearing life.

Shaft

These charts provide guidelines for specifying shaft fits for spherical roller bearings in different operating conditions for solid steel shafts. For numerical values see pages 40-45.

Cleaning

See the General Bearing Handling and Inspection Section for information about proper cleaning and inspection techniques for all anti-friction bearings.

Installation

See the General Bearing Handling and Inspection Section for information about proper installation techniques for all anti-friction bearings.

See the Shaft and Housing Requirements Section for general information about checking and preparing shafts and housings prior to bearing installation.

	Conditions	Examples	Shaft Diameter mm in.		Tolerance Symbol ⁽¹⁾	Remarks
Bearings With Straight Bore						
Stationary inner ring load	The inner ring to be easily displaced on the shaft	Two-bearing shaft mechanism	See table on page 94 for shaft size		s4	See table on page 94 for shaft size
	The inner ring not to be displaced on the shaft	Wheel on non-rotating shaft	All diameters		g6	
		Tension pulleys and rope sheaves			h6	
Rotating inner ring load or indeterminate load direction	Light and variable loads $P \leq 0.07C$ ⁽²⁾	Electrical apparatus, machine tools, pumps, ventilators, industrial trucks	Over 18 0.7086 100 3.9370	Incl. 100 3.9370 200 7.8740	k6 m6	In very accurate applications k5 and m5 are used instead of k6 and m6 respectively.
	Normal and heavy loads $P > 0.07C$ ⁽²⁾ $\leq 0.25C$ ⁽²⁾	General applications, electrical motors, turbines, pumps, combustion engines, gear transmissions, woodworking machines	18 0.7086 65 2.5590 100 3.9370 140 5.5118 280 11.0236 500 19.6850	65 2.5590 100 3.9370 140 5.5118 280 11.0236 500 19.6850 and up	m5 m6 n6 p6 r6 r7	
	Very heavy loads and shock loads $P > 0.25C$ ⁽²⁾	Journal boxes for locomotives and other heavy rail vehicles, traction motors	18 0.7086 65 2.5590 100 3.9370 140 5.5118 200 7.8740	65 2.5590 100 3.9370 140 5.5118 200 7.8740 500 19.6850	m6 n6 p6 r6 r7	Bearings with greater clearance than normal must be used.
Bearings With Tapered Bore And Adapter Sleeve						
	All loads	Applications in general	All diameters			See tables for Reduction of RIC on page 97

⁽¹⁾ For solid steel shafts. See tables on pages 40-45 for numerical value.

⁽²⁾ C = Dynamic load rating.

Housing

These charts provide guidelines for specifying housing fits for spherical roller bearings in different operating conditions.

Conditions		Examples	Tolerance Symbol ⁽¹⁾	Remarks
One piece bearing housing	Rotating outer ring load	Variable load direction	P6	The outer ring is not displaceable axially
		Heavy loads on bearings in thin walled housings	P7	
		Normal and heavy loads	N7	
		Light and variable loads	M7	
	Conveyor rollers, rope sheaves, tension pulleys			
	Indeterminate load direction	Heavy shock loads	Electrical traction motors	K7
Heavy and normal loads, axial displacement of outer ring not required		Electrical motors, pumps, crankshaft main bearings		
Normal and light loads, axial displacement of the outer ring desirable		Electrical motors, pumps, crankshaft main bearings		
Split or one piece bearing housing	Stationary outer ring load	Shock loads, temporarily complete unloading	J7	The outer ring is displaceable axially
		Journal boxes for rail vehicles	H7	The outer ring is easily displaced axially
		All loads		
		Bearing applications in general, journal boxes for rail vehicles		
	Normal and light loads, loads under simple operating conditions	H8		
Heat supplied through the shaft	G7			
One piece bearing housing	Applications requiring particular accuracy	Very accurate running and small deflections under variable loads	M6 N6 P6	The outer ring is not displaced axially
		For main spindles in machine tools O.D. less than 125 mm O.D. 125 to 250 mm O.D. over 250 mm	K6	The outer ring is not displaceable axially
		Very accurate running under light loads and indeterminate load direction		
Very accurate running, axial displacement of outer ring desirable	J6	The outer ring is easily displaced axially		

⁽¹⁾ For cast iron or steel housing. For numerical values see tables on pages 46-53. For housings of light metal, tolerances generally are selected which give a slightly tighter fit than those given in the table.



SPHERICAL ROLLER BEARINGS

The s4 fit designation as referenced on this page is a special fit tolerance developed by The Timken Company for this specific application. It DOES NOT conform to ISO standards similarly published as s4 preferred shaft fits.

s4 FITS

A centrifugal force load produces a rotating outer ring load and a stationary inner ring load, even though the inner ring rotates. This makes it desirable to fit the outer ring tight in the housing, and the inner ring loose on the shaft using an s4 fit as listed in the table. The standard W33 bearing with oil groove and oil holes can be used.

Bore mm/in.		Variance from Nominal Bore			
Over	Incl.	Tolerance +0	Shaft Diameter		Fit
			Max.	Min.	
		mm in.	mm in.	mm in.	mm in.
50.000 1.9685	80.000 3.1996	-0.015 -0.0006	-0.025 -0.0010	-0.036 -0.0014	.010L .036L .0004L .0014L
80.000 3.1996	120.000 4.7294	-0.020 -0.0008	-0.033 -0.0013	-0.043 -0.0017	.013L .043L .0005L .0017L
120.000 4.7294	180.000 7.0866	-0.025 -0.0010	-0.041 -0.0016	-0.053 -0.0021	.015L .053L .0006L .0021L
180.000 7.0866	250.000 9.8425	-0.030 -0.0012	-0.048 -0.0019	-0.064 -0.0025	.018L .064L .0007L .0025L

Table 2. s4 Fits.

MOUNTING PROCEDURES

Depending on the size of the bearing and the application, there are different methods for mounting roller bearings. In all methods, certain basic rules must be followed.

Cleanliness

- Choose a clean environment, free from dust or moisture.
- The installer should make every effort to ensure cleanliness by use of protective screens and clean cloths.

Plan the work

Know your plans in advance and have the necessary tools at hand. This reduces the amount of time for the job and decreases the chance for dirt to get into the bearing.

Inspection and preparation

- All component parts of the machine should be on hand and thoroughly cleaned before proceeding.
- Housings should be cleaned, including blowing out the oil holes.
- If blind holes are used, insert a magnetic rod to remove metal chips that might be lodged there during fabrication.
- Shaft shoulders and spacer rings contacting the bearing should be square with the shaft axis.
- The shaft fillet must be small enough to clear the radius of the bearing.
- On original installations, all component parts should be checked against the detail specification prints for dimensional accuracy. The shaft and housing should be carefully checked for size and form (roundness, etc.).

Shaft and housing finish

- Shaft surfaces on which the bearing will be mounted must be clean and free from nicks and burrs.
- For applications with a stationary housing and a rotating shaft, it is suggested that the bearing seat on the shaft be ground to 1.6 μm (65 R_a μin) maximum.
- If it is impractical to use a ground finish, a machined finish of 3.2 μm (125 R_a μin) is acceptable in many cases, but the amount of interference fit should be slightly increased.
- For a stationary outer ring, which is required to float (e.g., slide axially in the housing), a housing finish of 1.6 μm (65 R_a μin) maximum is suggested.
- Where the outer ring is not required to float, a surface finish of 3.2 μm (125 R_a μin) maximum.

MOUNTING CYLINDRICAL BORE BEARINGS

Heat expansion method

- Most applications require a tight interference fit on the shaft.
- Mounting is simplified by heating the bearing to expand it sufficiently to slide easily onto the shaft.
- Two methods of heating are commonly used:
 - Tank of heated oil.
 - Induction heating.

Tank of heated oil

- The first is accomplished by heating the bearing in a tank of oil that has a high flash point.
- The oil temperature should not be allowed to exceed 120°C (250°F). A temperature of 90°C (200°F) is sufficient for most applications.
- The bearing should be heated for 20 or 30 minutes per inch of inner-ring cross section to fully heat in an oil tank.
- The bearing should not be in direct contact with the heat source.
- The usual arrangement is to have a screen several inches from the bottom of the tank. Small support blocks separate the bearing from the screen.
- It is important to keep the bearing away from any localized high-heat source that may raise its temperature excessively, resulting in race hardness reduction.
- Flame-type burners are commonly used. An automatic device for temperature control is desirable.
- If safety regulations prevent the use of an open heated oil bath, a mixture of 15 percent soluble-oil water may be used. This mixture may be heated to a maximum of 90°C (200°F) without being flammable.

Induction heating

- The induction heating method is used for mounting small bearings in production line assembly.
- Induction heating is rapid. Care must be taken to prevent bearing temperature from exceeding 120°C (250°F).
- Trial runs with the unit and bearing are usually necessary to obtain proper timing.
- Thermal crayons melting at predetermined temperatures can be used to check the bearing temperature.
- While the bearing is hot, it should be positioned squarely against the shoulder.
- Lockwashers and locknuts or clamping plates are then installed to hold the bearing against the shoulder of the shaft.

- As the bearing cools, the locknut or clamping plate should be tightened.
- In cases of outer ring rotation, where the outer ring is a tight fit in the housing, the housing member can be expanded by heating.

Arbor press method

- The alternate method of mounting, generally used only on smaller sizes, is to press the bearing onto the shaft or into the housing. This can be done by using an arbor press and a mounting tube.
- The tube can be made from soft steel with an inside diameter slightly larger than the shaft.
- The O.D. of the tube should not exceed the maximum shoulder height given in the table of dimensions.
- The tube should be faced square at both ends. It should be thoroughly clean inside and out, and long enough to clear the end of the shaft after the bearing is mounted.
- If the outer ring is being pressed into the housing, the O.D. of the mounting tube should be slightly smaller than the housing bore. The I.D. should not be less than the suggested housing backing diameter in the tables of dimensions.
- Coat the shaft with a light machine oil to reduce the force needed for a press fit.
- Carefully place the bearing on the shaft, making sure it is square with the shaft axis.
- Apply steady pressure from the arbor ram to drive the bearing firmly against the shoulder.
- Never attempt a press fit on a shaft by applying pressure to the outer ring, or a press fit in a housing by applying pressure to the inner ring.

Shaft Mounting Tapered Bore Spherical Roller Bearings

- Refer to the charts on pages 25 and 26 for the correct Reduction of RIC due to Installation.
- Place the bearing in an upright position with the inner and outer ring faces parallel.
- Place the thumbs on the inner ring bore and oscillate the inner ring two or three elements.
- Position the individual roller assemblies so that a roller is at the top of the inner ring on both sides of the bearing.
- With the roller in the correct position, insert a thin blade of the feeler gage between the roller and the outer ring.
- Move it carefully along the top roller, between the roller and outer ring raceway. Repeat this procedure, using thicker feeler gage blades, until one is found that will not go through.



SPHERICAL ROLLER BEARINGS

NOTE: Tapered bore bearings must have the proper amount of radial internal clearance before installation to provide for the required reduction of RIC during mounting and to compensate for any further internal reduction from abnormal temperature conditions. For special applications, send complete operating data to your Timken representative for suggestions on radial internal clearance.

- The blade thickness that preceded the “no-go” blade is a measure of radial internal clearance (RIC) before installation (Fig. 30).
- Start the mounting procedure by lubricating the tapered shaft with a light coat of machine oil.
- Slide the bearing onto the shaft as far as it will go.
- As the locknut is tightened, the interference fit builds up resulting in expansion of the inner ring.
- Periodically measure to keep track of the reduction in RIC.
- Continue the procedure until the proper amount of reduction is obtained. Do not exceed suggested amount of reduction.
- As a final check, make sure that the remaining RIC equals or exceeds the minimum mounted clearance.
- During mounting, the RIC should be checked at the unloaded roller. If this is at the bottom, make sure that the roller is raised to seat firmly at the inboard position of the inner race (Fig. 31).
- When the suggested amount of reduction of RIC has been accomplished, the bearing is properly fitted.
- Complete the procedure by peening the lockwasher tang into the locknut slot or securing the lockplate.

Example #1 - Calculating RIC Reduction Using a Spherical Roller Bearing with Tapered Bore

Given bearing number 22328K C3 (140 mm bore with a C3 clearance) is to be mounted on a tapered shaft. Using a set of feeler gauges, RIC is found to be –

$$\text{RIC} = 0.178 \text{ mm (0.007 in.)}$$

Suggested reduction of RIC due to installation = 0.065 to 0.090 mm (0.0026 in. to 0.0035 in.), found in chart on page 97.

Calculate the clearance after mounting –

$$0.178 \text{ mm} - 0.077 \text{ mm} = 0.101 \text{ mm or}$$

$$0.007 \text{ in.} - 0.003 \text{ in.} = 0.004 \text{ in.}$$



Fig. 30. Measure of RIC before installation.



Fig. 31. During mounting, the RIC should be checked at the unloaded roller.

NOTE: For this example, the value of 0.077 mm (0.003 in.) was obtained by taking the mid-range value of the upper and lower limits found in the table on page 97.

Therefore, the locking nut should be tightened until RIC reaches 0.101 mm (0.004 in.).

It should also be noted that the value obtained by reading the Suggested RIC after Installation directly from the table is 0.075 mm (0.0030 in.). This differs from the value calculated in the above example. The value taken directly from the table is provided as a minimum value. It is not suggested to use a calculated value that falls below this minimum.

SAF PILLOW BLOCK ASSEMBLIES

Mounting adapters versus straight bore

Spherical roller bearing pillow block assemblies are typically mounted to a straight shaft using a tapered bore bearing and adapter assembly. Standard commercial shafting can be used without additional machining.

Adapter mounts also permit maximum flexibility in the axial positioning of the bearing on the shaft, and will accommodate light location thrust loads. Timken pillow blocks for tapered-bore and adapter-mounted bearings are available in Series 225, 226, 230, 231K and 232K.

Mounting tapered bore spherical roller bearings

Nominal Bearing Bore (mm)		Radial Internal Clearance Prior to Mounting (mm)						Suggested Reduction of RIC (mm)		Axial Displacement Tapered Shaft Installation (mm)				Minimum Permissible RIC After Installation		
		Normal		C3		C4				1:12 Taper ⁽¹⁾		1:30 Taper ⁽¹⁾		Normal	C3	C4
over	incl.	Max.	Min.	Max.	Min.	Max.	Min.	Max.	Min.	Max.	Min.	Max.	Min.			
30	40	0.050	0.035	0.065	0.050	0.085	0.065	0.025	0.020	0.380	0.300	-	-	0.015	0.025	0.040
40	50	0.060	0.045	0.080	0.060	0.100	0.080	0.030	0.025	0.460	0.380	-	-	0.020	0.030	0.050
50	65	0.075	0.055	0.095	0.075	0.120	0.095	0.040	0.030	0.560	0.460	-	-	0.025	0.040	0.060
65	80	0.095	0.070	0.120	0.095	0.150	0.120	0.050	0.040	0.760	0.560	-	-	0.025	0.045	0.075
80	100	0.110	0.080	0.140	0.100	0.180	0.140	0.065	0.045	0.970	0.680	-	-	0.035	0.050	0.075
100	120	0.135	0.100	0.170	0.135	0.220	0.170	0.070	0.050	1.070	0.760	2.540	1.900	0.050	0.060	0.100
120	140	0.160	0.120	0.200	0.160	0.260	0.200	0.090	0.065	1.270	0.890	3.050	2.290	0.055	0.075	0.115
140	160	0.180	0.130	0.230	0.180	0.300	0.230	0.100	0.075	1.520	1.140	3.430	2.670	0.055	0.075	0.125
160	180	0.200	0.140	0.260	0.200	0.340	0.260	0.115	0.075	1.650	1.140	4.060	2.670	0.060	0.090	0.150
180	200	0.220	0.160	0.290	0.220	0.370	0.290	0.125	0.090	1.900	1.400	4.450	3.050	0.070	0.100	0.165
200	225	0.250	0.180	0.320	0.250	0.410	0.320	0.140	0.100	2.030	1.520	4.830	3.560	0.075	0.115	0.180
225	250	0.270	0.200	0.350	0.270	0.450	0.350	0.150	0.115	2.290	1.780	5.330	4.060	0.090	0.115	0.200
250	280	0.300	0.220	0.390	0.300	0.490	0.390	0.165	0.115	2.540	1.780	5.840	4.060	0.100	0.140	0.230
280	315	0.330	0.240	0.430	0.330	0.540	0.430	0.180	0.125	2.670	1.900	6.220	4.450	0.100	0.150	0.250
315	355	0.360	0.270	0.470	0.360	0.590	0.470	0.190	0.140	2.790	2.030	6.600	4.830	0.115	0.165	0.280
355	400	0.400	0.300	0.520	0.400	0.650	0.520	0.200	0.150	3.050	2.290	7.110	5.330	0.130	0.190	0.330
400	450	0.440	0.330	0.570	0.440	0.720	0.570	0.215	0.165	3.300	2.540	7.620	5.840	0.150	0.230	0.360
450	500	0.490	0.370	0.630	0.490	0.790	0.630	0.230	0.180	3.430	2.670	8.000	6.220	0.165	0.270	0.410
500	560	0.540	0.410	0.680	0.540	0.870	0.680	0.250	0.200	3.810	3.050	8.890	7.110	0.180	0.290	0.440
560	630	0.600	0.460	0.760	0.600	0.980	0.760	0.280	0.230	4.190	3.430	9.780	8.000	0.200	0.320	0.510
630	710	0.670	0.510	0.850	0.670	1.090	0.850	0.300	0.250	4.570	3.810	10.670	8.890	0.200	0.370	0.550
710	800	0.750	0.570	0.960	0.750	1.220	0.960	0.350	0.280	5.330	4.190	12.450	9.780	0.230	0.390	0.610
800	900	0.840	0.640	1.070	0.840	1.370	1.070	0.380	0.300	5.720	4.570	13.330	10.670	0.250	0.460	0.690
900	1000	0.930	0.710	1.190	0.930	1.520	1.190	0.430	0.350	6.480	5.334	15.110	12.450	0.280	0.490	0.750
1000	1120	1.030	0.770	1.300	1.030	1.670	1.300	0.480	0.400	7.240	6.100	16.890	14.220	0.280	0.550	0.810
1120	1250	1.120	0.830	1.420	1.120	1.830	1.420	0.500	0.430	7.620	6.480	17.780	15.110	0.330	0.610	0.910

Note: Axial displacement values apply to solid steel shafts or hollow steel shafts with bore diameter less than half the shaft diameter. For shaft materials other than steel, or for thin-wall shafts, please consult your Timken representative.

⁽¹⁾ 1:12 Taper used for 222, 223, 230, 231, 232, 233, 239 series. 1:30 Taper used for 240, 241, 242 series. For sleeve mounting, multiply axial displacement values by 1.1 for 1:12 taper or by 1.05 for 1:30 taper. For questions on tapered shaft data, consult your Timken representative.

Adapter-mounted spherical roller bearings require the correct removal of RIC from the bearing to prevent relative rotation between the inner race and the sleeve or shaft. Failure to use proper mounting procedures can allow the inner race to slip on the shaft, creating heat and reducing bearing performance.

In applications with heavy thrust loads, or where exact axial location or a positive shaft interference fit are required, a direct straight bore mounting may be the best option. This requires a shouldered shaft, machined for proper fit and a straight bore bearing.

Timken pillow block assemblies for straight bore applications are available in Series 222, 223, 231 and 232. See pages 40-45 for suggested shaft diameters.

For applications involving heavy shock, vibration, unbalanced rotating loads or other abnormal conditions, consult your Timken representative.

Fixed and float pillow blocks

Any Timken pillow block can be easily installed in the float or fixed position on the shaft. For the fixed position, a stabilizing ring is added between the bearing outer ring face and the housing shoulder to positively locate the shaft and prevent axial movement.

Some applications require centering of the bearing in its housing. To accomplish this, two special width-stabilizing rings can be ordered.

Most Timken pillow blocks are supplied with a stabilizing ring. This should be discarded for the float positions. In the float position the ring is not used, allowing the bearing to move axially up to 9.5 mm (0.375 in.) to compensate for thermal expansion or contraction of the shaft.

Closed end installations

In some applications, the shaft end is designed to terminate inside the pillow block. For these designs, positive-fitting end closure inserts are available to seal out contaminants and retain lubricants.

Timken heavy duty end plugs include O-rings for positive sealing. When installing, make sure the shaft end does not contact the closure. A minimum of 3 mm (0.125 in.) clearance at maximum thermal expansion is suggested between the end of the shaft and the closure.

Dimension Y in the Timken Products Catalog tables defines the maximum permissible length of the shaft from the center line of the pillow block housing. If end closure is desired, specify by adding CL (one end closed) to the pillow block assembly number.

Mounting tapered-bore spherical roller bearings in an SAF assembly

Follow these general precautions when installing a tapered bore spherical roller bearing in an SAF assembly:

- The cap and base for each block are machined as one unit. Do not interchange components with other units.
- Make sure the LER seal rings have a good coating of grease over the entire ring after assembly. This ensures a proper seal for the block and prevents excess wear.
- Protect all unpainted metallic surfaces with clean, anti-corrosion solution.
- Cover the shaft and bearing with a clean shop towel if the assembly process is delayed.
- Make sure the shaft is free of burrs, nicks or damage and is properly sized.

Follow this procedure when installing a tapered bore spherical roller bearing in an SAF assembly:

- Slide the inboard seal on the shaft.
- Slide the adapter sleeve onto the shaft with the threads facing out. Laterally position this sleeve at the approximate center of the assembled bearing position.
- Slide the bearing onto the adapter sleeve and locate it on the shaft. For straight bore bearings, mount the bearing on the shaft as described on page 94. Make sure the inboard seal is on the shaft.
- If possible, leave the lock washer off at this point. Tighten the locknut with a 180° spanner wrench, measuring the RIC after each quarter turn, until the proper reduction of RIC is obtained. See RIC reduction in Section C (page 97) of this manual.
- Remove the locknut and place the lock washer against the bearing with the inner diameter prong pointing toward the bearing while in the groove in the sleeve. Find the lock washer tang that is closest to the locknut slot, and peen over the tang into the slot opening.
- Slide the outboard seal onto the shaft. Position both the inboard and outboard seals to line up with grooves in the housing block.
- Prepare the housing by removing any paint or burrs found on the split block's mating surfaces, then oil the bearing seat.

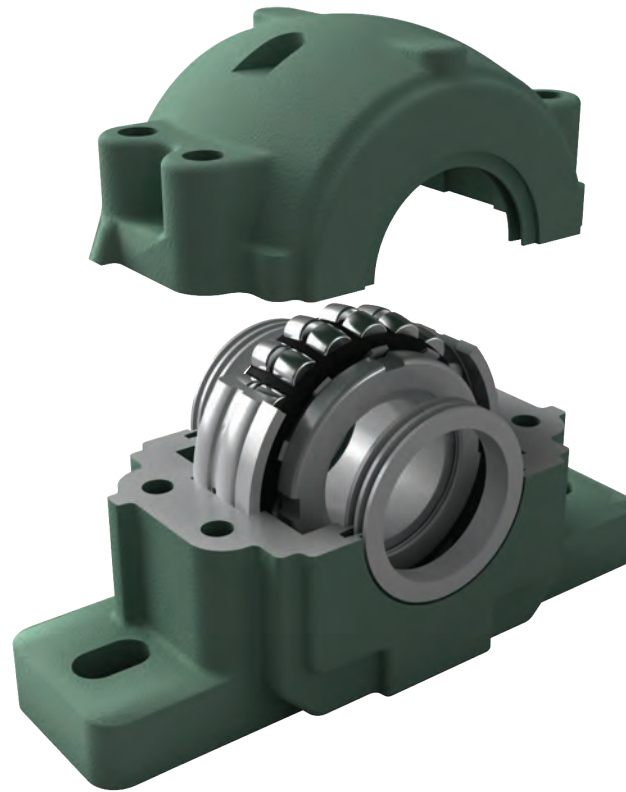

- Place the shaft with the mounted bearing into the pillow block base. Make sure the seals line up with the grooves in the housing.
- Bolt the housing to the mounting surface. Ensure the bearing outer ring sits squarely in the bearing seat.
- For axially fixed blocks, adjust the shaft if necessary, and insert the stabilizing ring between the bearing and the block shoulder on the locknut side, if possible.
- Adjust the other bearing(s) to the center(s) of their respective base(s). For high temperature applications, consult with your Timken representative for proper bearing placement in the base. Always fix only one pillow block on the shaft and allow the remaining bearing(s) to float on the shaft. This allows for axial expansion of the system.
- Apply grease or oil bath lubricant. See the Lubrication and Seals Section of this manual for more information.
- Prepare the cap by removing any paint or burrs found on the split block's mating surfaces. Oil the bearing seat and lower the cap onto the base, aligning the dowel pins. Do not shear off dowel pins if the cap cannot be attached. If you have trouble aligning the dowel pins, rotate it 180°. Originally machined block halves should always be able to mate without modification.
- To prevent oil leakage, apply a small amount of sealing compound around the outer edges of the mating halves. Be careful not to apply too much as the compound can work into the bearing and result in an improper fit.
- Bolt the cap to its base using the bolts and washers provided. Torque all four bolts to standard bolt specs uniformly to maintain proper load distribution.



CYLINDRICAL ROLLER BEARINGS

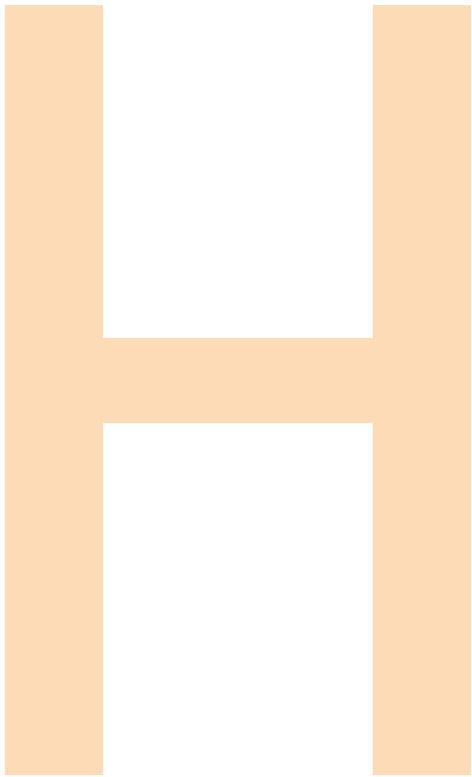

H CYLINDRICAL ROLLER BEARINGS

Cylindrical Roller Bearings.....	103
Storage And Handling.....	104
Mounting Cylindrical Bore Bearings.....	104



CYLINDRICAL ROLLER BEARINGS

H

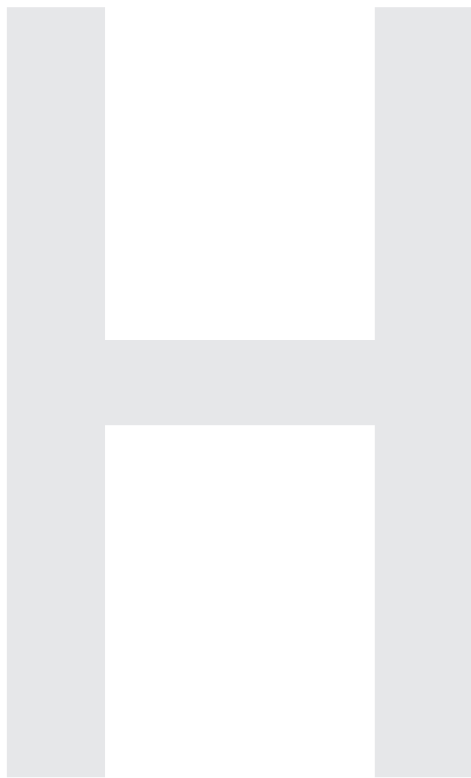

CYLINDRICAL ROLLER BEARINGS

A radial cylindrical roller bearing consists of an inner and/or outer ring, a roller retaining cage and a complement of controlled contour cylindrical rollers. Timken cylindrical bearings provide the highest possible radial load capacity compared to other roller bearing types. Three basic styles are available to meet a variety of application requirements:

- **One-row Cylindrical Bearings:** Available in six types. Each has the same cage type, but inside and outside ring configurations vary to accommodate different application designs.
- **Two-row Cylindrical Bearings:** Customized designs are available upon request (currently not a standard catalog item) and offer added radial capacity over traditional one-row types.
- **Four-row Cylindrical Bearings:** Has an extremely high radial load capacity, but no thrust capacity. Mostly used in roll neck applications in the metals industry.

Sizes: 15 mm – 2000 mm (0.591 in. to 78.740 in.) and 140 mm – 2000 mm (5.512 in. to 78.740 in.).

*The second size range is for four-row only.

Applications: Industrial applications for pulp and paper, power generation, oilfield, mining, aggregate, wind turbines, gear drives and rolling mills.

Design Attributes: The bearings can be selected with separable inner and outer races.

Customer Benefits: Heavy radial load capacity extends bearing life, reducing maintenance time and costs.



STORAGE AND HANDLING

See the General Bearing Handling and Inspection Section for guidelines regarding how to handle bearings.

New Timken bearings are normally distributed in packaging that provides necessary protection against dirt and moisture. There is no need to wash new bearings because the rust preventive on the bearing is compatible with normal lubricants. To prevent bearing contamination, do not remove the bearing from its packaging until ready for installation, and do not leave open bearings lying on the floor or workbench.

Cleaning

See the General Bearing Handling and Inspection Section for information about proper cleaning and inspection techniques for all anti-friction bearings.

Installation

See the General Bearing Handling and Inspection Section for information about proper installation techniques for all anti-friction bearings.

See the Shaft and Housing Requirements Section for general information about checking and preparing shafts and housings prior to bearing installation.

MOUNTING CYLINDRICAL BORE BEARINGS

Depending on the size of the bearing and the application, there are different methods for mounting roller bearings. In all methods, certain basic rules must be followed.

Cleanliness

- Choose a clean environment, free from dust or moisture.
- The installer should make every effort to ensure cleanliness by use of protective screens and clean cloths.

Plan the work

Know in advance your plans and have the necessary tools at hand. This reduces the amount of time for the job and decreases the chance for dirt to get into the bearing.

Inspection and preparation

- All component parts of the machine should be on hand and thoroughly cleaned before proceeding.
- Housings should be cleaned, including blowing out the oil holes.
- If blind holes are used, insert a magnetic rod to remove metal chips that might be lodged there during fabrication.

- Shaft shoulders and spacer rings contacting the bearing should be square with the shaft axis.
- The shaft fillet must be small enough to clear the radius of the bearing.
- On original installations, all component parts should be checked against the detail specification prints for dimensional accuracy. The shaft and housing should be carefully checked for size and form (roundness, etc.).

Shaft and housing finish

- Shaft surfaces on which the bearing will be mounted must be clean and free from nicks and burrs.
- For applications with a stationary housing and a rotating shaft, it is suggested that the bearing seat on the shaft be ground to 1.6 μm (65 Ra μin) maximum.
- If it is impractical to use a ground finish, a machined finish of 3.2 μm (125 Ra μin) is acceptable in many cases, but the amount of interference fit should be slightly increased.
- For a stationary outer ring, which is required to float (e.g., slide axially in the housing), a housing finish of 1.6 μm (65 Ra μin) maximum is suggested.
- Where the outer ring is not required to float, a surface finish of 3.2 μm (125 Ra μin) maximum is generally satisfactory.

Heat expansion method

- Most applications require a tight interference fit on the shaft.
- Mounting is simplified by heating the bearing to expand it sufficiently to slide easily onto the shaft.
- Two methods of heating are commonly used:
 - Tank of heated oil.
 - Induction heating.

Tank of heated oil

- The first is accomplished by heating the bearing in a tank of oil that has a high flash point.
- The oil temperature should not be allowed to exceed 120°C (250°F). A temperature of 90°C (200°F) is sufficient for most applications.
- The bearing should be heated for 20 or 30 minutes per inch of inner-ring cross section to fully heat in an oil tank.
- If safety regulations prevent the use of an open heated oil bath, a mixture of 15 percent soluble-oil water may be used. This mixture may be heated to a maximum of 93°C (200°F) without being flammable.

- The bearing should not be in direct contact with the heat source.
- The usual arrangement is to have a screen several inches from the bottom of the tank. Small support blocks separate the bearing from the screen.
- It is important to keep the bearing away from any localized high-heat source that may raise its temperature excessively, resulting in race hardness reduction.
- Flame-type burners are commonly used. An automatic device for temperature control is desirable.

Induction heating

- The induction heating method is used for mounting small bearings in production line assembly.
- Induction heating is rapid. Care must be taken to prevent bearing temperature from exceeding 120°C (250°F).
- Trial runs with the unit and bearing are usually necessary to obtain proper timing.
- Thermal crayons melted at predetermined temperatures can be used to check the bearing temperature.
- While the bearing is hot, it should be positioned squarely against the shoulder.
- Lockwashers and locknuts or clamping plates are then installed to hold the bearing against the shoulder of the shaft.
- As the bearing cools, the locknut or clamping plate should be tightened.
- In cases of outer ring rotation, where the outer ring is a tight fit in the housing, the housing member can be expanded by heating.

Arbor press method

- The alternate method of mounting, generally used only on smaller sizes, is to press the bearing onto the shaft or into the housing. This can be done by using an arbor press and a mounting tube.
- The tube can be made from soft steel with an inside diameter slightly larger than the shaft.
- The O.D. of the tube should not exceed the maximum shoulder height given in the table of dimensions.
- The tube should be faced square at both ends. It should be thoroughly clean inside and out, and long enough to clear the end of the shaft after the bearing is mounted.

⚠ CAUTION Failure to observe the following cautions could create a risk of injury:

If the bearing is to be reused or returned for repair, do not use heat from a torch.
Extreme heat from a torch can alter the bearing hardness and metallurgical structure, resulting in irreparable damage.

- If the outer ring is being pressed into the housing, the O.D. of the mounting tube should be slightly smaller than the housing bore. The I.D. should not be less than the suggested housing basking diameter in the tables of dimensions.
- Coat the shaft with a light machine oil to reduce the force needed for a press fit.
- Carefully place the bearing on the shaft, making sure it is square with the shaft axis.
- Apply steady pressure from the arbor ram to drive the bearing firmly against the shoulder.
- Never attempt a press fit on a shaft by applying pressure to the outer ring, or a press fit in a housing by applying pressure to the inner ring.

CYLINDRICAL ROLLER BEARINGS

These tables provide guidelines for shaft and housing fits related to particular operating conditions.

Shaft

Cylindrical Roller Bearings (Except 5200 Series)						
Operating Conditions	Examples	Loads		Shaft Diameter mm in.	Shaft Tolerance Symbol ⁽¹⁾	
		Lower Load Limit	Upper Load Limit			
Inner Ring Stationary						
Inner ring to be easily displaced on shaft	Wheels Non-rotating shafts	0	C ⁽⁵⁾	All		g6
Inner ring does not need to be easily displaced	Tension pulleys	0	C	All		h6
Inner Ring Rotating, or Indeterminate						
				Over mm in.	Incl. mm in.	
Light loads	Electrical apparatus Machine tools Pumps Ventilators Industrial trucks	0	0.08C	0	40	j6 ⁽⁶⁾
				0	1.57	k6 ⁽³⁾
				40	140	m6 ⁽⁴⁾
				1.57	5.51	n6
				140	320	p6
				5.51	12.60	
				320	500	
				12.60	19.68	
				500	—	
				19.68	—	
Normal loads	Electrical motors Turbines Pumps Combustion engines Gear transmissions etc.	0.08C	0.18C	0	40	k5
				0	1.57	m5
				40	100	m6
				1.57	3.94	n6
				100	140	p6
				3.94	5.51	r6
				140	320	
				5.51	12.60	
				320	500	
				12.60	19.68	
Heavy loads Shock loads	Rail vehicles Traction motors	0.18C	C	0	40	m5 ⁽³⁾
				0	1.57	m6 ⁽³⁾
				40	65	n6 ⁽³⁾
				1.57	2.56	p6 ⁽³⁾
				65	140	r6 ⁽³⁾
				2.56	5.51	r7 ⁽³⁾
				140	320	
				5.51	12.60	
				320	500	
				12.60	19.68	
Thrust Loads						
Pure thrust loads	All	Not recommended, consult Timken representative				

⁽¹⁾ For solid shaft. See pages 40-45 for numerical values.

⁽²⁾ Bearings with greater than nominal clearance must be used.

⁽³⁾ Use k5 for accurate applications.

⁽⁴⁾ Use m5 for accurate applications.

⁽⁵⁾ C = Dynamic Load Rating.

⁽⁶⁾ Use j5 for accurate applications.

Housing

Operating Conditions	Examples	Housing Tolerance Symbol ⁽¹⁾	Outer Ring Displaceable Axially
Outer Ring Rotating			
Heavy loads with thin-wall housing	Crane support wheels Wheel hubs (roller bearings) Crank bearings	P6	No
Normal to heavy loads	Wheel hubs (ball bearings) Crank bearings	N6	No
Light loads	Conveyor rollers Rope sheaves Tension pulleys	M6	No
Indeterminate Load Direction			
Heavy shock loads	Electric traction motors	M7	No
Normal to heavy loads, axial displacement of outer ring not required	Electric motors Pumps Crankshaft main bearings	K6	No, normally
Light to normal loads, axial displacement of outer ring desired	Electric motors Pumps Crankshaft main bearings	J6	Yes, normally
Outer Ring Stationary			
Shock loads, temporary complete unloading	Heavy rail vehicles	J6	Yes, normally
All Loads	One-piece housing	H6	Easily
	Radially split housing	H7	Easily
Heat supplied through shaft	Dryer cylinders	G7	Easily

⁽¹⁾ For cast iron or steel housing. See pages 46-53 for numerical values.

Where wider tolerances are permissible, P7, N7, M7, K7, J7 and H7 values may be used in place of P6, N6, M6, K6, J6, and H6 values respectively.

* Below this line, housing can either be one piece or split; above this line, a split housing is not suggested.

5200, A5200 Metric Series Shaft and Housing Fits and Tolerances

Shaft fits⁽¹⁾

Bearing Bore		Bore Tolerance +0	Press fit Rotating Inner Ring				Slip Fit Stationary Inner Ring			
Over	Incl.		Shaft Diameter		Fit	Shaft Diameter		Fit		
			Max.	Min.		Max.	Min.			
mm in.		mm in.	mm in.		mm in.		mm in.			
80.000 3.1496	120.000 4.7236	-0.020 -0.0008	0.048 0.0019	0.025 0.0010	0.025T 0.0010T	0.069T 0.0027T	0.000 0.0000	-0.023 -0.0009	.023L 0.0009L	.020T .0008T
120.000 4.7236	140.000 5.5108	-0.025 -0.0100	0.056 0.0022	0.030 0.0012	0.030T 0.0012T	0.081T 0.0032T	0.000 0.0000	-0.025 -0.0010	.025L 0.0010	.025T 0.0010
140.000 5.5108	180.000 7.0856	-0.025 -0.0010	0.071 0.0028	0.046 0.0018	0.046T 0.0018T	0.097T 0.0038T	0.000 0.0000	-0.025 -0.0010	.025L 0.0010	.025T 0.0010
180.000 7.0856	240.000 9.4476	-0.030 -0.0012	0.081 0.0032	0.051 0.0020	0.051T 0.0020T	0.112T 0.0044T	0.000 0.0000	-0.030 -0.0012	.030L 0.0012	.030T 0.0012

⁽¹⁾ When shaft is used as race surface, hardness to be Rc58 minimum and surface finish to be 15 microinches R_a.

Housing fits

Bearing Bore		O.D. Tolerance Inner Ring +0	Press fit Rotating Inner Ring				Slip Fit Stationary Inner Ring			
Over	Incl.		Housing Diameter		Fit	Housing Diameter		Fit		
			Max.	Min.		Max.	Min.			
mm in.		mm in.	mm in.		mm in.		mm in.			
- -	180.000 7.0866	-0.025 -0.0010	0.022 0.0008	-0.015 -0.0006	0.015T 0.0006T	0.046L 0.0018L	-0.025 -0.0010	-0.056 -0.0022	0.056T 0.0022T	0.000L 0.0000L
180.000 7.0866	200.000 7.874	-0.030 -0.0012	0.018 0.0007	-0.018 -0.0007	0.018T 0.0007T	0.048L 0.0019L	-0.030 -0.0012	-0.066 -0.0026	0.066T 0.0026T	0.000L 0.0000L
200.000 7.874	230.000 9.0551	-0.030 -0.0012	0.023 0.0009	-0.018 -0.0007	0.018T 0.007T	0.053L 0.0021L	-0.030 -0.0012	-0.066 -0.0026	0.066T 0.0026T	0.000L 0.0000L
230.000 9.0551	250.000 9.8425	-0.030 -0.0012	0.028 0.0011	-0.018 -0.0007	0.018T 0.0007T	0.058L 0.0023L	-0.030 -0.0012	-0.066 -0.0012	0.066T 0.0026T	0.000L 0.0000L
250.000 9.8425	270.000 10.6299	-0.036 -0.0014	0.028 0.0011	-0.018 -0.0007	0.018T 0.0007T	0.064L 0.0025L	-0.030 -0.0012	-0.071 -0.0028	0.071T 0.0028T	0.005L 0.0002L
270.000 10.6299	310.000 12.2047	-0.036 -0.0014	0.033 0.0013	-0.018 -0.0007	0.018T 0.0007T	0.069L 0.0027L	-0.036 -0.0014	-0.071 -0.0028	0.071T 0.0028T	0.005L 0.0002L
310.000 12.2047	400.000 15.748	-0.041 -0.0016	0.038 0.0015	-0.018 -0.0007	0.018T 0.0007T	0.079L 0.0031L	-0.036 -0.0014	-0.076 -0.0030	0.079T 0.0030T	0.005L 0.0002L
400.000 15.748	440.000 17.3228	-0.046 -0.0018	0.041 0.0016	-0.023 -0.0009	0.023T 0.0009T	0.086L 0.0034L	-0.036 -0.0034	-0.086 -0.0014	0.086T 0.0034T	0.010L 0.0004L



Radial internal clearance (RIC)

Bearing Bore		Radial Internal Clearance	
Over	Incl.	Max.	Min.
mm in.		mm in.	
– –	100.000 3.9370	0.183 0.0072	0.127 0.0050
100.000 3.9370	120.000 4.7244	0.188 0.0074	0.127 0.0050
120.000 4.7244	140.000 5.5118	0.208 0.0082	0.142 0.0056
140.000 5.5118	170.000 6.6929	0.224 0.0088	0.152 0.0060
170.000 6.6929	180.000 7.0866	0.229 0.0090	0.152 0.0060
180.000 7.0866	220.000 8.6614	0.254 0.0100	0.173 0.0068
220.000 8.6614	240.000 9.4488	0.269 0.0106	0.183 0.0072

Inner ring tolerances

Bearing Bore		Bore & Inner O.D. +0	Width +0
Over	Incl.		
mm in.		mm in.	mm in.
80.000 3.1496	120.000 4.7244	-0.020 -0.0008	-0.203 -0.0080
120.000 4.7244	180.000 7.0866	-0.025 -0.0010	-0.254 -0.0100
180.000 7.0866	250.000 9.8425	-0.030 -0.0012	-0.305 -0.0120

Outer ring tolerances

Bearing O.D.		O.D. +0	Diameter Under Rollers -0
Over	Incl.		
mm in.		mm in.	mm in.
150.000 5.9055	180.000 7.0866	-0.025 -0.0010	0.036 0.0014
180.000 7.0866	250.000 9.8425	-0.030 -0.0012	0.041 0.0016
250.000 9.8425	315.000 12.4016	-0.036 -0.0014	0.046 0.0018
315.000 12.4016	400.000 15.7480	-0.041 -0.0016	0.051 0.0020
400.000 15.7480	500.000 19.6850	-0.046 -0.0018	0.056 0.0022

Shaft dimensions - 5200 bearings without inner ring

Bearing Number	Slip Fit Housing ⁽¹⁾		Press Fit Housing ⁽¹⁾	
	Max.	Min.	Max.	Min.
	mm in.	mm in.	mm in.	mm in.
5220 WS	121.064 4.7663	121.044 4.7655	121.036 4.7652	121.016 4.7644
5222 WS	133.007 5.2365	132.987 5.2357	132.969 5.2350	132.949 5.2343
5224 WS	145.194 5.7163	145.174 5.7155	145.156 5.7148	145.136 5.7140
5226 WS	155.042 6.1040	155.016 6.1030	155.004 6.1025	154.978 6.1015
5228 WS	168.529 6.6350	168.504 6.6340	168.491 6.6335	168.466 6.6325
5230 WS	181.623 7.1505	181.597 7.1495	181.587 7.1490	181.559 7.1480
5232 WS	193.713 7.6265	193.688 7.6255	193.675 7.6250	193.650 7.6240
5234 WS	205.562 8.0930	205.537 8.0920	205.524 8.0915	205.499 8.0905
5236 WS	216.370 8.5185	216.344 8.5175	216.319 8.5165	216.294 8.5155
5238 WS	229.032 9.0170	229.001 9.0158	228.994 9.0155	228.963 9.0143
5240 WS	242.296 9.5392	242.265 9.5380	242.245 9.5372	242.214 9.5360
5244 WM	266.020 10.4725	265.971 10.4713	265.951 10.4705	265.92 10.4693
5248WM	291.292 11.4682	291.262 11.4670	291.241 11.4662	291.211 11.4650

⁽¹⁾ All shaft diameters are based on a housing bore to housing O.D. ratio of 0.7.

THRUST BEARINGS



I THRUST BEARINGS

Thrust Bearings.....	111
Storage And Handling.....	112



THRUST BEARINGS

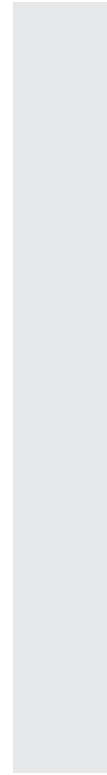

THRUST BEARINGS

Thrust bearings are designed specifically to manage heavy thrust loads and provide high-shock-load resistance for maximum bearing life and load capacity. Timken manufactures several basic thrust bearing designs, including:

- **Ball Thrust Bearings:** Standard axial (Type TVB) and angular contact (Types TVL and DTVL) ball thrust designs are available.
- **Spherical Roller Thrust Bearings:** Type TSR bearings are ideal for applications where conditions include heavy loads, difficulties in establishing or maintaining housing alignment and problems with shaft deflection.
- **Cylindrical Roller Thrust Bearings:** Designed to operate under heavy loads at moderate speeds. Types include standard (Type TP) and aligning washer (Type TPS).
- **Tapered Roller Thrust Bearings:** Ensures true rolling motion for maximum bearing life and load-carrying capacity. Available in both standard (heavy duty, v-flat, screw down, oscillating and crossed roller) and custom designs.

Sizes: 35 mm – 2940 mm (1.375 in. to 115.75 in.)

Applications: Industrial applications such as cone crushers, crane hooks, oil well swivels, pulverizer drives, rolling mills, machine tool spindles and tables, drilling rig hydraulic heads, gearboxes and pre-heater fans.

Customer Benefits: Complete line offers application flexibility and provides maximum bearing life and load capacity for top performance and reduced maintenance.

Thrust bearings are typically used in applications with very high thrust and shock load applications.



STORAGE AND HANDLING

See the General Bearing Handling and Inspection Section for guidelines regarding how to handle bearings.

New Timken bearings are normally distributed in packaging that provides necessary protection against dirt and moisture. There is no need to wash new bearings because the rust preventive on the bearing is compatible with normal lubricants. To prevent bearing contamination, do not remove the bearing from its packaging until ready for installation, and do not leave open bearings lying on the floor or workbench.

Cleaning

See the General Bearing Handling and Inspection Section for information about proper cleaning and inspection techniques for all anti-friction bearings.

Installation

See the General Bearing Handling and Inspection Section for information about proper installation techniques for all anti-friction bearings.

See the Shaft and Housing Requirements Section for general information about checking and preparing shafts and housings prior to bearing installation.

Thrust Roller Bearings Shaft and Housing Fits

Shaft and housing diameters shown as variance from nominal dimensions. Shaft and housing data shown in millimeters over inches.

Thrust ball bearings: Type TVB shaft

Bearing Bore Nominal (Min.)		Shaft Diameter	
Over	Incl.	Max.	Min.
mm in.	mm in.	mm in.	mm in.
0.000 0.0000	171.450 6.7500	+0 +0	-0.030 -0.0012
171.450 6.7500	508.000 20.0000	+0 +0	-0.038 -0.0015

Housing

Bearing Bore Nominal (Max.)		Housing Bore	
Over	Incl.	Max.	Min.
mm in.	mm in.	mm in.	mm in.
119.858 4.7188	441.325 17.3750	+0.229 +0.0090	-0.127 -0.0050
441.325 17.3750	1000.000 39.3701	+0.254 +0.0100	-0.152 -0.0060

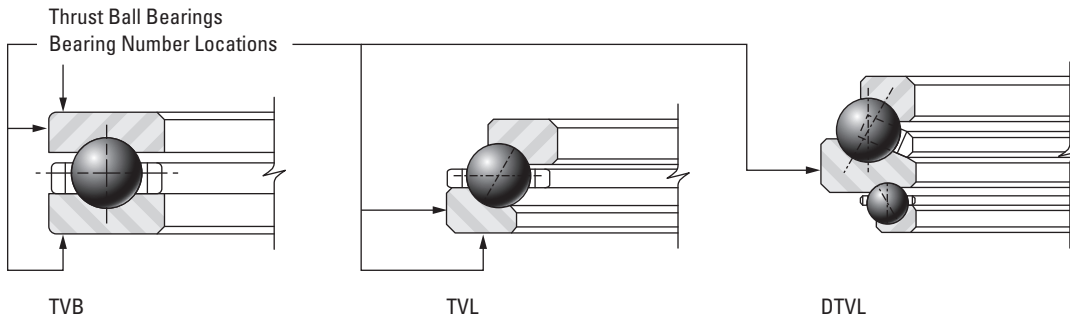

Thrust ball bearings: Type TVL and DTVL shaft

Bearing Bore Nominal (Max.)		Shaft Diameter			
		Interference Fit ⁽¹⁾		Loose Fit ⁽²⁾	
Over	Incl.	Max.	Min.	Max.	Min.
mm in.	mm in.	mm in.	mm in.	mm in.	mm in.
0.000 0.0000	504.825 19.8750	+0.076 +0.0030	+0 +0	-0.152 -0.0060	-0.076 -0.0030
504.825 19.8750	1524.000 60.0000	+0.127 +0.0050	+0 +0	-0.254 -0.0100	-0.127 -0.0050

Housing

Bearing O.D. Nominal (Min.)		Shaft Diameter			
		Loose Fit ⁽²⁾		Interference Fit ⁽¹⁾	
Over	Incl.	Max.	Min.	Max.	Min.
mm in.	mm in.	mm in.	mm in.	mm in.	mm in.
0.000 0.0000	584.000 23.0000	+0.152 +0.0060	0.076 0.0030	-0.152 -0.0060	-0.076 -0.0030
584.000 23.0000	1778.000 70.0000	+0.254 +0.0100	0.127 0.0050	-0.254 -0.0100	-0.127 -0.0050

⁽¹⁾ Dowel pin suggested.

⁽²⁾ Dowel pin required.

⁽¹⁾ Dowel pin suggested.

⁽²⁾ Dowel pin required.

Thrust Cylindrical Roller Bearings

Tolerances for housing bore and for shaft diameters shown as variance from nominal bearing dimension. Data shown in millimeters over inches.

Type TP and TPS shaft

Bearing Bore Nominal (Max.)		Shaft Diameter Deviation from Nominal Bore	
Over	Incl.	Max.	Min.
mm in.	mm in.	mm in.	mm in.
47.625 1.8750	53.975 2.1250	-0.025 -0.0010	-0.051 -0.0020
53.975 2.1250	63.500 2.5000	-0.028 -0.0011	-0.053 -0.0021
63.500 2.5000	76.200 3.0000	-0.030 -0.0012	-0.056 -0.0022
76.200 3.0000	88.900 3.5000	-0.033 -0.0012	-0.058 -0.0023
88.900 3.5000	177.800 7.0000	-0.038 -0.0015	-0.064 -0.0025
177.800 7.0000	228.600 9.0000	-0.038 -0.0015	-0.076 -0.0030
228.600 9.0000	304.800 12.0000	-0.046 -0.0018	-0.084 -0.00330
304.800 12.0000	381.000 15.0000	-0.051 -0.0020	-0.089 -0.0035
381.000 15.0000	482.600 19.0000	-0.051 -0.0020	-0.102 -0.0040
482.600 19.0000	584.200 23.0000	-0.064 -0.0025	-0.114 -0.0045
584.200 23.0000	762.000 30.0000	-0.076 -0.0030	-0.140 -0.0055

Type TP housing

Bearing O.D. Nominal (Min.)		Housing Bore Deviation from Nominal O.D.	
Over	Incl.	Max.	Min.
mm in.	mm in.	mm in.	mm in.
115.092 4.5312	254.000 10.0000	+0.076 +0.0030	+0.038 +0.0015
254.000 10.0000	457.200 18.0000	+0.102 +0.0040	+0.051 +0.002
457.200 18.0000	558.800 22.0000	+0.127 +0.0050	+0.064 +0.0025
558.800 22.0000	660.400 26.0000	+0.140 +0.0055	+0.064 +0.0025
660.400 36.0000	711.200 28.0000	+0.152 +0.0060	+0.076 +0.0030
711.200 28.0000	863.600 34.0000	+0.178 +0.0070	+0.076 +0.0030
863.600 34.0000	965.200 38.0000	+0.203 +0.0080	+0.089 +0.0035
965.200 38.0000	1117.600 44.0000	+0.229 +0.0029	+0.102 +0.0040

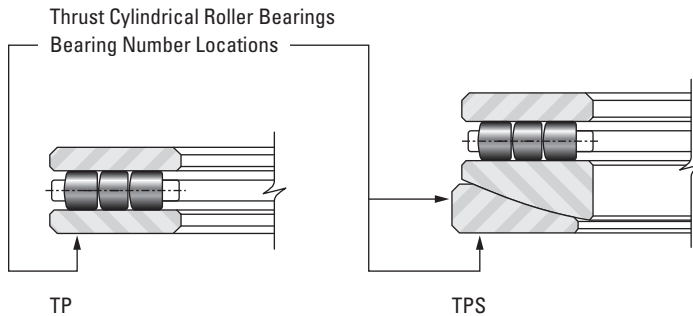

Type TPS housing

Bearing O.D. Nominal (Max.)		Housing Diameter Deviation from D Nominal O.D.	
Over	Incl.	Max.	Min.
mm in.	mm in.	mm in.	mm in.
50.800 2.0000	60.325 2.3750	+0.038 +0.0015	+0.013 +0.0005
60.325 2.3750	82.550 3.2500	+0.043 +0.0017	+0.018 +0.0070
82.550 3.2500	93.663 3.6875	+0.048 +0.0019	+0.023 +0.0009
93.663 3.6875	101.600 4.0000	+0.053 +0.0021	+0.028 +0.0011
101.600 4.0000	115.092 4.5312	+0.071 +0.0028	+0.033 +0.0013
115.092 4.5312	254.000 10.0000	+0.076 +0.0030	+0.038 +0.0015
254.000 10.0000	457.200 18.0000	+0.102 +0.0040	+0.051 +0.0020
457.200 18.0000	558.800 22.0000	+0.127 +0.0050	+0.064 +0.0025
558.800 22.0000	660.400 26.0000	+0.140 +0.0055	+0.064 +0.0025
660.400 26.0000	711.200 28.0000	+0.152 +0.0060	+0.076 +0.0030
711.200 28.0000	863.600 34.0000	+0.178 +0.0070	+0.076 +0.0030
863.600 34.0000	965.200 38.0000	+0.203 +0.0080	+0.089 +0.0035
965.200 38.0000	1117.600 44.0000	+0.229 +0.0090	+0.102 +0.0040

THRUST BEARINGS

Thrust Tapered Roller Bearings

Tolerances for housing bore and shaft diameters shown as variance from nominal bearing dimension. Data shown in millimeters over inches. When one washer is piloted by the housing, sufficient clearances must be allowed at the outside diameter of the other

washer as well as at the bore of both washers to prevent cross-threading of the rollers. For most applications, this clearance is approximately 1.588 mm (0.0625 inches).

Types TTV and TTVF shaft

Bearing Bore Nominal (Min.)		Shaft Diameter Max. Tolerance 0.000 mm 0.000 in. To
Over	Incl.	
mm in.	mm in.	mm in.
0.000 0.0000	304.800 12.0000	-0.051 -0.0020
304.800 12.0000	508.000 20.0000	-0.051 -0.0020
508.000 20.0000	711.200 28.0000	-0.076 -0.0030
711.200 28.0000	1219.200 48.0000	-0.102 -0.0040
1219.200 48.0000	1727.200 68.0000	-0.127 -0.0050

Housing

Bearing Bore Nominal (Min.)		Housing Bore	
Over	Incl.	Max.	Min.
mm in.	mm in.	mm in.	mm in.
161.925 6.3750	265.113 10.4375	0.060 0.0025	0.025 0.0010
265.113 10.3475	317.500 12.5000	0.076 0.0030	0.025 0.0010
317.500 12.5000	482.600 19.0000	0.102 0.0040	0.051 0.0020
482.600 19.0000	603.250 23.7500	0.113 0.0045	0.051 0.0020
603.250 23.7500	711.200 28.0000	0.152 0.0060	0.076 0.0030
711.200 28.0000	838.200 33.0000	0.178 0.0070	0.076 0.0030

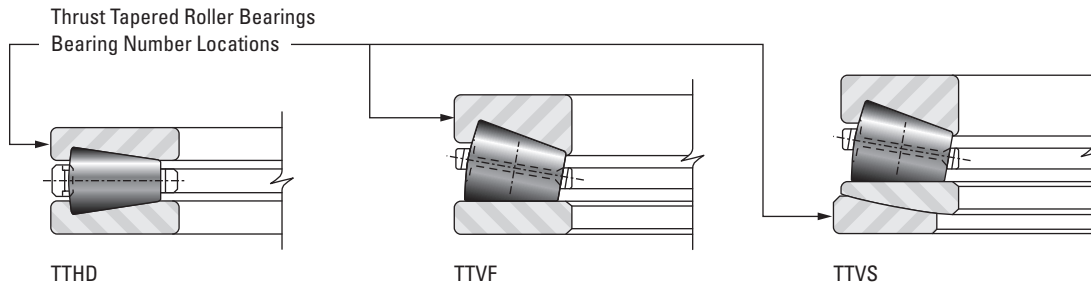

Thrust tapered roller bearings: Type TTHD shaft

Bearing Bore Nominal (Min.)		Spring Loaded Max.+0	Shaft Diameter	
Over	Incl.		Rolling Mill Screwdown and Piercing Mill Thrust Blocks	
mm in.	mm in.	mm in.	mm in.	mm in.
0.000 0.0000	174.625 6.8750	-0.025 -0.0010	+0.076 +0.0030	+0.051 +0.0020
174.625 6.8750	203.197 7.9999	-0.025 -0.0010	+0.102 +0.0040	+0.076 +0.0030
203.197 7.9999	304.800 12.0000	-0.038 -0.0015	+0.127 +0.0050	+0.102 +0.0040
304.800 12.0000	609.600 24.0000	-0.051 -0.0020	+0.178 +0.0070	+0.127 +0.0050
609.600 24.0000	914.400 36.0000	-0.064 -0.0025	+0.241 +0.0095	+0.178 +0.0070
914.400 36.0000	1219.200 48.0000	-0.076 -0.0030	+0.304 +0.0120	+0.229 +0.0090

Type TTHD housing

Bearing O.D. Nominal (Min.)		Housing Bore	
Over	Incl.	Max.	Min.
mm in.	mm in.	mm in.	mm in.
161.925 6.3750	266.700 10.5000	-0.064 +0.0025	+0.025 +0.0010
266.700 10.5000	330.200 13.0000	+0.076 +0.0030	+0.025 +0.0010
330.200 13.0000	508.000 20.0000	+0.120 +0.0040	+0.051 +0.0020
508.000 20.0000	635.000 25.0000	+0.114 +0.0045	+0.051 +0.0020
635.000 25.0000	762.000 30.0000	+0.152 +0.0060	+0.076 +0.0030
762.000 30.0000	889.000 35.0000	+0.178 +0.0070	+0.076 +0.0030

Thrust Spherical Roller Bearings

Tolerances for housing bore and for shaft diameters shown as variance from nominal bearing dimension. Data shown in millimeters over inches. When application calls for thrust loads only, the housing must be relieved by 1.588 mm (0.0625 in.) on diameter so that no radial load is carried on the bearing (Fig. 32).

Type TSR shaft

Bearing Bore Nominal (Max)		Shaft Diameter			
		Stationary Load		Rotating Load	
Over	Incl.	Max.	Min.	Max.	Min.
mm in.	mm in.	mm in.	mm in.	mm in.	mm in.
80.000 3.1496	120.000 4.7244	0.013 0.0005	-0.010 -0.0004	0.025 0.0010	0.003 0.0001
120.000 4.7244	180.000 7.0866	0.015 0.0006	-0.010 -0.0004	0.028 0.0011	0.003 0.0001
180.000 7.0866	200.000 7.8740	0.018 0.0007	-0.013 -0.0005	0.036 0.0001	0.005 0.0002
200.000 7.8740	240.000 9.4488	0.018 0.0007	-0.013 -0.0005	0.046 0.0018	0.015 0.0006
240.000 9.4488	315.000 12.4016	0.018 0.0007	-0.015 -0.0006	0.051 0.0020	0.020 0.0008
315.000 12.4016	400.000 15.7480	0.018 0.0007	-0.018 -0.0007	0.056 0.0022	0.020 0.0008
400.000 15.7480	500.000 19.6850	0.023 0.0009	-0.018 -0.0007	0.086 0.0034	0.046 0.0018
500.000 19.6850	630.000 24.8031	0.023 0.0009	-0.020 -0.0008	0.086 0.0034	0.043 0.0017

Type TSR housing

Bearing O.D. Nominal (Max.)		Housing Bore					
		Springs in Housing Light Radial Load		Combined Axial and Radial Load			
Over	Incl.			Max.	Min.	Max.	Min.
mm in.	mm in.	mm in.	mm in.	mm in.	mm in.	mm in.	mm in.
180.000 7.0866	250.000 9.8425	0.061 0.0024	0.015 0.0006	0.028 0.0011	-0.018 -0.0007	0.013 0.0005	-0.033 -0.0013
250.000 9.8425	315.000 12.4016	0.069 0.0027	0.018 0.0007	0.033 0.0013	-0.018 -0.0007	0.015 0.0006	-0.036 -0.0014
315.000 12.4016	400.000 15.7480	0.074 0.0029	0.018 0.0007	0.038 0.0015	-0.018 -0.0007	0.015 0.0006	-0.041 -0.0016
400.000 15.7480	500.000 19.6850	0.084 0.0033	0.020 0.0008	0.041 0.0016	-0.023 -0.0009	0.018 0.0007	-0.046 -0.0018
500.000 19.6850	630.000 24.8031	0.091 0.0036	0.023 0.0009	0.046 0.0018	-0.023 -0.0009	0.020 0.0008	-0.048 -0.0019
630.000 24.8031	800.000 31.4960	0.102 0.0040	0.023 0.0009	0.051 0.0020	-0.023 -0.0009	0.023 0.0009	-0.051 -0.0020
800.000 31.4960	1000.000 39.3700	0.109 0.0043	0.025 0.0010	0.058 0.0023	-0.025 -0.0010	0.025 0.0010	-0.058 -0.0023
1000.000 39.3700	1250.000 49.2126	0.122 0.0048	0.028 0.0011	0.066 0.0026	-0.028 -0.0011	0.030 0.0012	-0.064 -0.0025

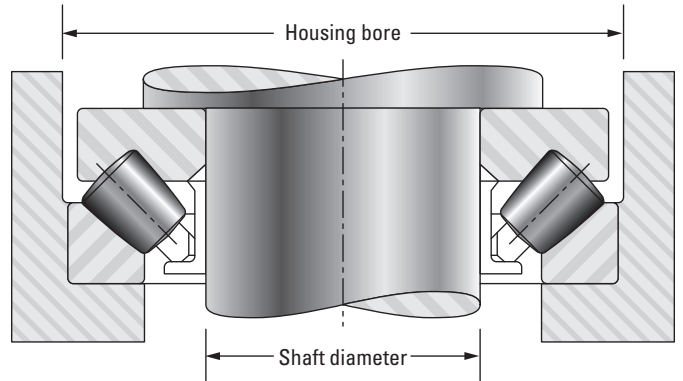
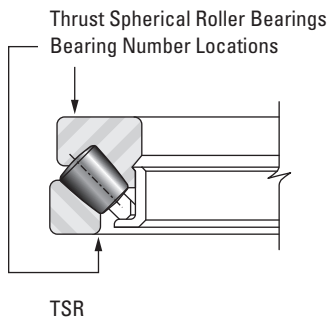

Fig. 32. The housing must be relieved by 1.588 mm (0.0625 in.) in diameter to ensure no radial load is carried.



BALL BEARINGS

J

J BALL BEARINGS

Ball Bearings	119
Storage And Handling	120
Radial Internal Clearance	120
Shaft Fits	121
Housing Fits	121
Wide Inner Ring Bearings	122
Ball Bearing Housed Units	123
Mounting Wide Inner Ring Bearings And Housed Units ..	124

BALL BEARINGS

J

J

BALL BEARINGS

Timken produces a broad range of Timken ball bearings to accommodate high precision applications at a variety of operating speeds. From standard deep groove radial ball bearings to advanced integral designs, Timken has the solution. Our ball bearing types include:

- **Radial Ball Bearings:** Tolerate relatively high-speed operation under a range of load conditions. Bearings consist of an inner and outer ring with a cage containing a complement of precision balls.
- **Angular Contact Ball Bearings:** Designed for combination radial and axial loading and are used in agricultural, chemical, utility and general industries.
- **Super-precision Ball Bearings:** Designed to meet demanding application requirements and are manufactured to ISO P4 (ABEC-7) and ISO P2 (ABEC-9) tolerances. Include miniature and instrument, thin section and ball screw support bearings.
- **Housed Units:** A variety of housing and seal configurations are available to accommodate many industrial designs and operating environments.

Sizes: 3 mm – 600 mm bore (0.118 in. – 23.622 in.)

Applications: Aircraft, construction, agriculture, machine tool and general industry applications.

Design Attributes: Designs available for either standard industrial or high precision applications.

Customer Benefits: Supports high axial loads and provide optimum performance in high precision, harsh operating environments. Options are available to simplify mounting and maintenance.



STORAGE AND HANDLING

See the General Bearing Handling and Inspection Section for general guidelines regarding how to handle ball bearings.

New Timken bearings are normally distributed in packaging that provides necessary protection against dirt and moisture. There is no need to wash new bearings because the rust preventive on the bearing is compatible with normal lubricants. To prevent bearing contamination, do not remove the bearing from its packaging until ready for installation, and do not leave open bearings lying on the floor or workbench.

Cleaning

See the General Bearing Handling and Inspection Section for information about proper cleaning and inspection techniques for all anti-friction bearings.

Installation

See the General Bearing Handling and Inspection Section for information about proper installation techniques for all anti-friction bearings.

See the Shaft and Housing Requirements Section for general information about checking and preparing shafts and housings prior to bearing installation.

Adjusting clearance

Standard manufacturing practice is to assemble ball bearings with a specified internal clearance. This clearance is necessary to allow for the effect of press fitting the bearing ring into its mounting during installation. In addition to allowing for thermal expansion of bearings, shafts and housings, this clearance can also provide a contact angle in the bearing after mounting.

Internal clearance can be measured either by gaging radially or axially. Radial measurement is accepted as the more significant characteristic because it is more directly related to shaft and housing fits. It is also the method prescribed by the ABMA.

RADIAL INTERNAL CLEARANCE

The radial internal clearance (RIC) of a radial contact ball bearing can be defined as follows:

- Average outer ring race diameter
- Average inner ring race diameter
- 2 x ball diameter
- = Radial internal clearance

RIC can be measured mechanically by moving the outer ring horizontally (Fig. 33).

The total movement of the outer ring when the balls are properly seated in the races determines the RIC. Several readings should be taken using different circumferential orientations of the rings in order to get a comprehensive average reading.

End play

End play is an alternate method of measuring internal clearance and is rarely used in radial ball bearings except for certain special applications. End play is determined by mounting the bearing with one of its rings clamped to prevent axial movement (Fig. 34).

A reversing measuring load is applied to the unclamped ring so that the resulting movement of that ring is parallel to the bearing axis. End play is the total movement of the unclamped ring when the load is applied first in one direction and then in the other.

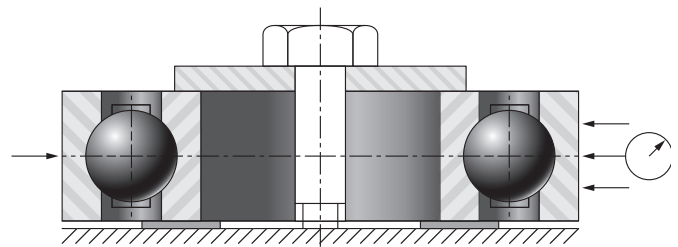

Fig. 33. RIC can be measured mechanically by moving the outer ring horizontally.

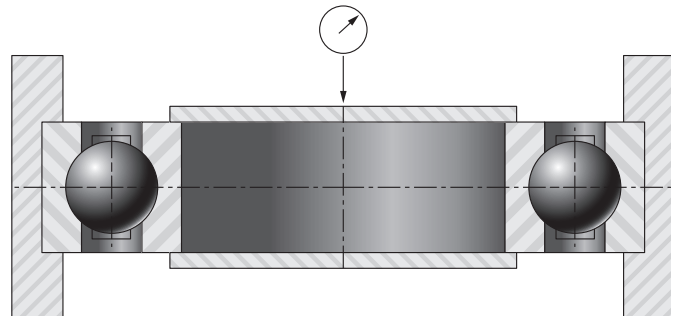

Fig. 34. Mounting the bearing with one of its rings clamped to prevent axial movement.

SHAFT FITS

ABEC-1 (ISO P0) and ABEC-3 (ISO P6) ball bearing shaft and housing fits

The tables on pages 125-137 list actual shaft and housing diameters for ABEC-1 (ISO P0), ABEC-3 (ISO P6) and 7000WN angular contact product family of ball bearings. These recommendations can be used for most applications having light to normal loads. Shaft and housing fits for wide inner ring ball bearings are found on page 140.

ABEC-7 (ISO P4) shaft fits

As a general rule, the shaft size and tolerance for seating ABEC-7 (ISO P4) super-precision bearings should be the same as the bearing bore, creating line-to-line fit. For larger shaft sizes, the average fit increases to a slight interference fit.

HOUSING FITS

Most applications will have a rotating shaft and stationary outer ring. In these applications, the outer ring should be installed on the shaft with no more than hand pressure or light tapping. In applications where the housing rotates, the outer ring should be pressed into the housing with the same amount of pressure.

In general, the minimum housing bore dimension for super-precision bearings is the same as the maximum bearing outside diameter. If the bearing O.D. tolerance is 0.0076 mm (0.0003 in.), the maximum housing bore should be no more than 0.0076 mm (0.0003 in.) larger than the minimum housing bore dimension.

In high-speed applications, it is extremely important that the floating bearing or pair of bearings can move axially to compensate for thermal changes. The bearing(s) cannot float laterally if they are restricted by a tight housing bore or by the radial expansion of the bearing itself. Contact your Timken representative for assistance in unusual application conditions.

All shaft and housing shoulders must be absolutely square, and the faces of the spacers square and parallel.

Selective assembly

In some applications it may be desirable to control fits more accurately without the added expense of using closer-tolerance bearings and mating parts. This can be accomplished by selective assembly of bearings, shafts and housings after they have been sized and grouped according to bores and outside diameters. Generally, it is more satisfactory for production and servicing to use closer shaft and housing tolerances with bearings having a higher degree of precision. Bearings with coded bores and outside diameters are available on special order to facilitate this selective assembly process.

Shafts and housing fillets

The suggested shaft and housing fillet radii listed in the dimension tables of the product catalogs should be used to ensure proper seating of the bearings against the shaft and housing shoulders. The manufacturing tolerances on bearing corner radii are such that the corners will clear the catalog fillet radii when the bearings are tightly seated against the shoulders.

Shaft and housing radii and shoulders should be free from nicks and burrs. Whenever possible, bearing seats and adjacent shoulders should be undercut to help avoid tapered bearing seats and ensure clearing corners.

Shafts and housing finish

Suggested shaft finishes for ABEC-1 (ISO P0) bearing applications are shown on page 34. These figures are to be used as a guide only. Special situations may demand better finishes.

For additional information on shaft and housing finish, see the Shaft and Housing Requirements Section of this manual.

Housing shoulders

To ensure a proper seat for the bearing on a shaft or in a housing, the shoulders must be accurate and perpendicular to the shaft axis. The shoulders should be large enough to exceed the theoretical point of tangency between the corner radius and the face of the bearing, and small enough to permit bearing removal with proper pullers.



WIDE INNER RING BEARINGS

Timken originated the wide inner ring ball bearing designs that easily mount on straight shafts (Fig. 35). The internal bearing construction is basically the same as the deep-race, single-row radial type with the ability to carry radial, thrust and combined loads. The inner ring is generally extended on both sides of the race to provide additional shaft support, and is locked to the shaft by specially designed setscrews or by the Timken-originated, eccentric, self-locking collar or concentric collar.

Wide inner ring bearings are also available with cylindrical or spherical outside diameters. The cylindrical or straight O.D. type is used for mounting in straight-bored housings. The spherical O.D. type must be mounted in a corresponding spherical seat and is used to compensate for shaft or housing misalignments.

Shaft and housing considerations

When selecting shafts for use with wide inner ring bearings, a minimum slip fit is desirable for the most satisfactory mounting. Special shaft limits are required in certain cases, and a variety of standard fits can be used, even including a press fit. For housing bore and shoulder diameters, refer to the table on page 138.

The suggested figures are noted below, but in some applications it may be permissible to use increased shaft tolerances. Contact your Timken representative for assistance.

Bearing bore tolerance

$\frac{1}{2}$ in. - $2\frac{3}{16}$ in. = nominal to +.013 mm (+.0005 in.)

$2\frac{1}{4}$ in. - $3\frac{3}{16}$ in. = nominal to +.015 mm (+.0006 in.)

$3\frac{7}{16}$ in. - $3\frac{15}{16}$ in. = nominal to +.018 mm (+.0007 in.)

Suggested shaft tolerances

$\frac{1}{2}$ in. - $1\frac{15}{16}$ in. = nominal to -.013 mm (-.0005 in.)

2 in. - $3\frac{15}{16}$ in. = nominal to -.025 mm (-.0010 in.)

Bearings with locking collars

RR-series: These bearings feature the flare out, contact type R-seal that encloses a synthetic rubber impregnated washer between two metal caps. Most sizes incorporate a shroud seal design. (Fig. 36)

RA-RR series: The RA-RR Series features an extended inner ring and self-locking collar for simple effective shaft retention in a standard series bearing. The positive contact, land-riding R-seal provides improved protection against the heavy contamination

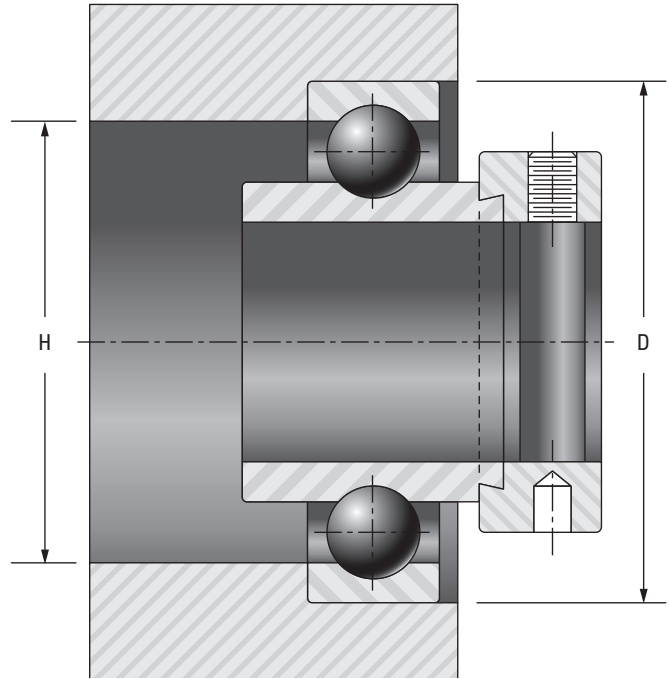

Fig. 35. Wide inner ring ball bearing.

encountered in many applications. All sizes have a heat-stabilized, moisture-conditioned six/six nylon retainer that has proven extremely effective under conditions of misalignment. (Fig. 37)

Tri-ply-seal series: These bearings are designed for environments where severe conditions and moisture are present. The new one-piece tri-ply-seals incorporate a highly effective seal design molded to an exterior shroud cap. The shroud cap protects the seal lips from fiber wrap and abrasion while enhancing the overall sealing effectiveness of the unit. All units incorporate the self-locking collar and have a nylon retainer. (Fig. 38)

External self-aligning series: The construction of this series permits the inner assembly that contains an open-type ball bearing with spherical O.D. to align in the seat of the mating outer ring. The seat of this outer ring is matched with the spherical O.D. of the ball bearing outer ring providing unrestricted self-alignment that allows the inner assembly to become square and true with the shaft. (Fig. 39)

RA-DD series bearings: This series features an extended inner ring with cam locking collar. It incorporates two close-fitting non-contact grease shields to effectively retain lubricant and provide protection against harmful contaminants. The non-contact metallic shields provide improved high speed and low torque performance such as required for high speed printing press applications. The 6/6 molded nylon retainer has proven extremely effective under conditions of misalignment. These bearings are dimensionally interchangeable and have the same load capacities as the RA-RR series.

J

Wide inner ring bearings with concentric collars

GC-RRB series: These bearings are relubricated with spherical outside diameters, nylon retainers and shroud seals. The metal shroud maintains tight seal contact against the inner ring and shields the rubber seals from damage due to dirt or fiber wrap. The concentric collar is locked to the shaft by two setscrews, located 120° apart, which are mated with threaded holes in the collar and drilled holes in the bearing inner ring. (Fig. 40)

BALL BEARING HOUSED UNITS

Ball bearing housed units are available in a wide variety of types and sizes to accommodate a complete range of operating conditions. They generally have cast iron housings and are designed for mounting on straight shafts with a slip fit.

The self-locking collar and the setscrew inner bearing designs provide easy mounting. Bolt holes in housings take standard bolts for assembling these units to machinery frames. Several series are also available with the concentric-locking collar. Most of these units are self-aligning.

There are several basic types of housed units available: pillow blocks, flanged cartridges, flangette units, cylindrical cartridges and take-up units. The type required is generally determined by its application and mounting requirements. Within the basic type selected, numerous variations allow for load factors, shaft sizes, mounting surface dimensions, base-to-shaft center line heights and lubrication requirements.

Pillow blocks: These are the most commonly used type of mounted units, designed to provide shaft support where the mounting surface is parallel to the shaft axis. The bolt holes are usually slotted for adjustment during mounting (Fig. 41). Pillow blocks are supplied in both standard and heavy duty series. Pressed steel and rubber pillow blocks are also available for light duty applications.

Flanged cartridges: These housed units are used where a shaft passes through the machine frame at a right angle. A four-bolt mounting is the most common; however, where the mounting area is restricted, three and two-bolt versions are available. A piloted-flanged cartridge, also available, provides additional mounting accuracy and support. (Fig. 42)

Flanged cartridges are supplied in both standard and heavy duty series. Iron and rubber flanged cartridges are also available. A complete line of flangette units, pressed steel flanged cartridges, provides an economical solution to light duty applications. Two-, three- and four-bolt mountings are available along with a relubricating version.



Fig. 36. RR-Series.



Fig. 37. RA-RR-Series.

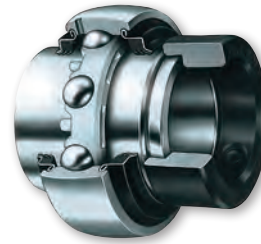

Fig. 38. Tri-ply Series.



Fig. 39. External self-aligning series.



Fig. 40. GC-RRB series.



Fig. 41. Pillow block.



Fig. 42. Flanged cartridge.



Cylindrical cartridges: Like flanged cartridges, cylindrical cartridges provide shaft support where the shaft axis is perpendicular to and passing through a machined housing that is generally very thick. The outside diameter of the cylindrical cartridges permits mounting with a press fit into a straight, through-bored housing.

Cylindrical cartridges have a machined spherical bearing seat to provide initial shaft alignment in standard duty applications. Synthetic, conductive rubber cylindrical cartridges are also available for applications where low-cost, light-duty, low-noise operation is essential. (Fig. 43)

Take up units: These units are used where shaft adjustment and belt tightening devices are required, such as conveyor applications. Frames for take up units provide for either side or top mounting. Take up units are available in cast iron for standard-duty, and are available in pressed steel for economical, light-duty applications. (Fig. 44)



Fig. 43. Cylindrical cartridges.



Fig. 44. Take up units.

MOUNTING WIDE INNER RING BEARINGS AND HOUSED UNITS

Installing bearings with cam self-locking collars

Most Timken housed units come equipped with the self-locking collar to facilitate mounting the wide inner ring bearings. The self-locking collar eliminates the need for locknuts, washers, shoulders, sleeves and adapters.

The locking collar has a counter-bored recess that is made purposely eccentric to the bore. The collar recess and the end of the bearing inner ring with which it engages are both machined so that they act as mating cams when on the shaft. When the collar is engaged to the inner ring, it grips the shaft tightly with a positive binding action that increases with use. No adjustments are necessary.

- Slip the shaft through the pillow block or housed unit that incorporates the wide inner ring bearing. Be certain the bearing is aligned in position along the shaft. Do not tighten the locking mechanism at this time.

- Fasten the housed unit securely to its base using the proper bolt size.
- Place the self-locking collar on the shaft with its cam adjacent to the cam on the end of the bearing's inner ring.
- Turn the collar in the direction of shaft rotation. The eccentric recessed cam will slide over and engage the corresponding cam on the bearing inner ring. Turn the collar until they are tightly engaged.
- Insert a drift pin in the collar hole. Using a lightweight hammer, strike the drift pin in the direction of the shaft rotation. This will lock the inner ring to the shaft.
- Tighten the setscrew in the collar. This exerts a wedging action to hold the collar in the engaged position, even under shock loads. In most cases, this design will operate effectively after the cams are tightly locked even without tightening the setscrews.

Installing bearings with concentric collars

On units equipped with concentric collar bearings, the collar is normally assembled to the wide inner ring for shipment. Slip the complete unit on the shaft following steps one and two described above, and tighten both setscrews.

Installing bearings with setscrews

- Slip the shaft through the pillow block or housed units that incorporates the wide inner ring bearing. Be certain the bearing is aligned in position along the shaft. Do not tighten the locking mechanism at this time.
- Fasten the housed unit securely to its base using the proper bolt size.
- Tighten each inner ring setscrew to the suggested torque listed by shaft size. It may be necessary to rotate the shaft to gain access to the setscrews.

Shaft Size	Suggested Torque
mm in.	N-m lbs-in.
17 1/2 – 11/16	4 N-m 35 lbs-in.
20-25 3/4 – 1	9 N-m 80 lbs-in.
30-45 1 1/16 – 1 3/4	18 N-m 155 lbs-in.
50-55 1 13/16 – 2 3/16	31 N-m 275 lbs-in.

Table 3. Suggested torque by shaft size.

**Radial ball bearing:
shaft fits, ABEC-1 (ISO P0), ABEC-3 (ISO P6)**

These tables are used for applications where only one ring, either inner or outer, has an interference fit with its shaft and housing. The guidelines for operating conditions covering these tables are found on page 134. In cases where interference fits are used for both rings, bearings with a special internal clearance may be required.

Shaft diameter dimensions are for solid steel shafts. Contact your Timken representative regarding applications using hollow shafts.

Extra-Small 30, S, F - Flanged Series

Basic Bearing Number	Bore Tolerance		Shaft Rotating, Load Stationary or Shaft Stationary, Load Rotating				Shaft Stationary, Load Stationary or Shaft Rotating, Load Rotating			
			Shaft Diameter		Mean Fit Tight		Shaft Diameter		Mean Fit Loose	
	Max.	Min.	Max.	Min.	ABEC-1	ABEC-3	Max.	Min.	ABEC-1	ABEC-3
	mm in.		mm in.		mm in.		mm in.		mm in.	
33K3, F33K3	3.175 0.1250	3.167 0.1247	3.180 0.1252	3.175 0.1250	0.006 0.00025	0.005 0.00020	3.170 0.1248	3.162 0.1245	0.005 0.00020	0.006 0.00025
33K4	3.175 0.1250	3.167 0.1247	3.180 0.1252	3.175 0.1250	0.006 0.00025	0.005 0.00020	3.170 0.1248	3.162 0.1245	0.005 0.00020	0.006 0.00025
33K5	4.762 0.1875	3.754 0.1872	4.768 0.1877	4.762 0.1875	0.006 0.00025	0.005 0.0002	4.752 0.1873	4.750 0.1870	0.005 0.00020	0.006 0.00025
34K	4.000 0.1575	3.992 0.1572	4.006 0.1577	4.001 0.1575	0.006 0.00025	0.005 0.0002	3.995 0.1573	3.988 0.1570	0.005 0.00020	0.006 0.00025
35K	5.000 0.1969	4.992 0.1966	5.006 0.1971	5.001 0.1969	0.006 0.00025	0.005 0.0002	4.996 0.1967	4.989 0.1964	0.005 0.00020	0.006 0.00025
36K	6.000 0.2362	5.992 0.2359	6.005 0.2364	5.999 0.2362	0.006 0.00025	0.005 0.0002	5.994 0.236	5.987 0.2357	0.005 0.00020	0.006 0.00025
37K	7.000 0.2756	6.992 0.2753	7.005 0.2758	6.998 0.2755	0.005 0.00020	0.004 0.00015	6.995 0.2754	6.985 0.275	0.006 0.00025	0.008 0.0003
38K, 38KV	8.000 0.3150	7.992 0.3147	8.006 0.3152	7.998 0.3149	0.005 0.00020	0.004 0.00015	7.996 0.3148	7.986 0.3144	0.006 0.00025	0.008 0.0003
39K	9.000 0.3543	8.992 0.3540	9.004 0.3545	8.997 0.3542	0.005 0.00020	0.004 0.00015	8.994 0.3541	8.984 0.3537	0.006 0.00025	0.008 0.0003
S1K,S1K7, FS1K7	6.350 0.2500	6.342 0.2497	6.355 0.2502	6.347 0.2499	0.005 0.00020	0.004 0.00015	6.345 0.2498	6.335 0.2494	0.006 0.00025	0.008 0.0003
S3K, FS3K	9.525 0.3750	9.517 0.3747	9.530 0.3752	9.522 0.3749	0.005 0.00020	0.004 0.00015	9.520 0.3748	9.510 0.3744	0.006 0.00025	0.008 0.0003
S5K	12.700 0.5000	12.692 0.4997	12.705 0.5002	12.697 0.4999	0.005 0.00020	0.004 0.00015	12.695 0.4998	12.682 0.4993	0.008 0.0003	0.009 0.00035
S7K	15.875 0.6250	15.867 0.6247	15.880 0.6252	15.872 0.6249	0.005 0.00020	0.004 0.00015	15.870 0.6248	15.857 0.6243	0.008 0.0003	0.009 0.00035
S8K	19.050 0.7500	19.040 0.7496	19.060 0.7504	19.053 0.7501	0.011 0.00045	0.009 0.00035	19.042 0.7497	19.030 0.7492	0.009 0.00035	0.011 0.00045
S9K	22.225 0.8750	22.215 0.8746	22.235 0.8754	22.228 0.8751	0.011 0.00045	0.009 0.00035	22.217 0.8747	22.205 0.8742	0.009 0.00035	0.011 0.00045
S10K	25.400 1.0000	25.390 0.9996	25.410 1.0004	25.403 1.0001	0.011 0.00045	0.009 0.00035	25.392 0.9997	25.380 0.9992	0.009 0.00035	0.011 0.00045
S11K	28.575 1.1250	28.565 1.1246	28.585 1.1254	28.578 1.1251	0.011 0.00045	0.009 0.00035	28.567 1.1247	28.555 1.1242	0.009 0.00035	0.011 0.00045
S12K	31.750 1.2500	31.737 1.2495	31.763 1.2505	31.753 1.2501	0.014 0.00055	0.011 0.00045	31.740 1.2496	31.725 1.249	0.011 0.00045	0.014 0.00055
F2DD-2	3.183 0.1253	3.175 0.1250	3.175 0.1250	3.167 0.1247	0.008 0.00030	0.006 0.00025	3.175 0.125	3.167 0.1247	0.008 0.0003	0.006 0.00025
F2	4.770 0.1878	4.762 0.1875	4.762 0.1875	4.755 0.1872	0.008 0.00030	0.006 0.00025	4.762 0.1875	4.755 0.1872	0.008 0.0003	0.006 0.00025
F3	4.770 0.1878	4.762 0.1875	4.762 0.1875	4.755 0.1872	0.008 0.00030	0.006 0.00025	4.762 0.1875	4.755 0.1872	0.008 0.0003	0.006 0.00025
F4	6.358 0.2503	6.350 0.2500	6.350 0.2500	6.342 0.2497	0.008 0.00030	0.006 0.00025	6.350 0.2500	6.342 0.2497	0.008 0.0003	0.006 0.00025
F5	7.946 0.3128	7.938 0.3125	7.938 0.3125	7.930 0.3122	0.008 0.00030	0.006 0.00025	7.938 0.3125	7.930 0.3122	0.008 0.0003	0.006 0.00025



Radial ball bearing: shaft fits, ABEC-1 (ISO P0), ABEC-3 (ISO P6)

9100, 9300, 200, 300, 5200, 5300 Series

Basic Bearing Number	Bore Tolerance		Shaft Rotating, Load Stationary or Shaft Stationary, Load Rotating				Shaft Stationary, Load Stationary or Shaft Rotating, Load Rotating			
			Shaft Diameter		Mean Fit Tight		Shaft Diameter		Mean Fit Loose	
	Max.	Min.	Max.	Min.	ABEC-1	ABEC-3	Max.	Min.	ABEC-1	ABEC-3
	mm in.		mm in.		mm in.		mm in.		mm in.	
0	10.000 0.3937	9.992 0.3934	10.005 0.3939	9.997 0.3936	0.005 0.0002	0.004 0.00015	9.995 0.3935	9.985 0.3931	0.006 0.00025	0.008 0.00030
1	12.000 0.4724	11.992 0.4721	12.004 0.4726	11.996 0.4723	0.005 0.0002	0.004 0.00015	11.994 0.4722	11.981 0.4717	0.008 0.00030	0.009 0.00035
2	15.000 0.5906	14.992 0.5903	15.006 0.5908	14.999 0.5905	0.005 0.0002	0.004 0.00015	14.996 0.5904	14.983 0.5899	0.008 0.00030	0.009 0.00035
3	17.000 0.6693	16.992 0.6690	17.005 0.6695	16.998 0.6692	0.005 0.0002	0.004 0.00015	16.995 0.6691	16.982 0.6686	0.008 0.00030	0.009 0.00035
4	20.000 0.7874	19.990 0.7870	20.010 0.7879	20.002 0.7875	0.013 0.0005	0.009 0.00035	19.992 0.7871	19.980 0.7866	0.009 0.00035	0.011 0.00045
5	25.000 0.9843	24.990 0.9839	25.014 0.9848	25.004 0.9844	0.013 0.0005	0.009 0.00035	24.994 0.9840	24.981 0.9835	0.009 0.00035	0.011 0.00045
6	30.000 1.1811	29.990 1.1807	30.010 1.1816	30.002 1.1812	0.013 0.0005	0.009 0.00035	29.992 1.1808	29.980 1.1803	0.009 0.00035	0.011 0.00045
7	35.000 1.3780	34.987 1.3775	35.014 1.3785	35.004 1.3781	0.014 0.0006	0.011 0.00045	34.991 1.3776	34.976 1.3771	0.011 0.00045	0.014 0.00055
8	40.000 1.5748	39.987 1.5743	40.013 1.5753	40.002 1.5749	0.014 0.0006	0.011 0.00045	39.990 1.5744	39.975 1.5738	0.011 0.00045	0.014 0.00055
9	45.000 1.7717	44.987 1.7712	45.014 1.7722	45.004 1.7718	0.014 0.0006	0.011 0.00045	44.991 1.7713	44.976 1.7707	0.011 0.00045	0.014 0.00055
10	50.000 1.9685	49.987 1.9680	50.013 1.9690	50.002 1.9686	0.014 0.0006	0.011 0.00045	49.990 1.9681	49.974 1.9675	0.011 0.00045	0.014 0.00055
11	55.000 2.1654	54.985 2.1648	55.016 2.1660	55.004 2.1655	0.017 0.0007	0.014 0.00055	54.991 2.165	54.973 2.1643	0.011 0.00045	0.014 0.00055
12	60.000 2.3622	59.985 2.3616	60.015 2.3628	60.002 2.3623	0.017 0.0007	0.014 0.00055	59.990 2.3618	59.972 2.3611	0.011 0.00045	0.014 0.00055
13	65.000 2.5591	64.985 2.5585	65.016 2.5597	65.004 2.5592	0.017 0.0007	0.014 0.00055	64.991 2.5587	64.973 2.5580	0.011 0.00045	0.014 0.00055
14	70.000 2.7559	69.985 2.7553	70.015 2.7565	70.002 2.7560	0.017 0.0007	0.014 0.00055	69.990 2.7555	69.972 2.7548	0.011 0.00045	0.014 0.00055
15	75.000 2.9528	74.985 2.9522	75.016 2.9534	75.004 2.9529	0.017 0.0007	0.014 0.00055	74.991 2.9524	74.973 2.9517	0.011 0.00045	0.014 0.00055
16	80.000 3.1496	79.985 3.149	80.015 3.1502	80.002 3.1497	0.017 0.0007	0.014 0.00055	79.990 3.1492	79.972 3.1485	0.011 0.00045	0.014 0.00055
17	85.000 3.3465	84.980 3.3457	85.019 3.3472	85.004 3.3466	0.020 0.0008	0.017 0.00065	84.988 3.346	84.968 3.3452	0.013 0.00050	0.017 0.00065
18	90.000 3.5433	89.980 3.5425	90.018 3.5440	90.002 3.5434	0.020 0.0008	0.017 0.00065	89.987 3.5428	89.967 3.542	0.013 0.00050	0.017 0.00065
19	95.000 3.7402	94.980 3.7394	95.019 3.7409	95.004 3.7403	0.020 0.0008	0.017 0.00065	94.988 3.7397	94.968 3.7389	0.013 0.00050	0.017 0.00065
20	100.000 3.9370	99.980 3.9362	100.018 3.9377	100.002 3.9371	0.020 0.0008	0.017 0.00065	99.987 3.9365	99.967 3.9357	0.013 0.00050	0.017 0.00065
21	105.000 4.1339	104.980 4.1331	105.019 4.1346	105.004 4.1340	0.020 0.0008	0.017 0.00065	104.988 4.1334	104.968 4.1326	0.013 0.00050	0.017 0.00065
22	110.000 4.3307	109.980 4.3299	110.018 4.3314	110.002 4.3308	0.020 0.0008	0.017 0.00065	109.987 4.3302	109.967 4.3294	0.013 0.00050	0.017 0.00065

J

Radial ball bearing: shaft fits, ABEC-1 (ISO P0), ABEC-3 (ISO P6)

Extra large series

Basic Bearing Number	Bore Tolerance		Shaft Rotating, Load Stationary or Shaft Stationary, Load Rotating				Shaft Stationary, Load Stationary or Shaft Rotating, Load Rotating			
			Shaft Diameter		Mean Fit Tight		Shaft Diameter		Mean Fit Loose	
	Max.	Min.	Max.	Min.	ABEC-1	ABEC-3	Max.	Min.	ABEC-1	ABEC-3
	mm in.		mm in.		mm in.		mm in.		mm in.	
124, 224, 324	120.000 4.7244	119.980 4.7236	120.018 4.7251	120.002 4.7245	0.020 0.0008	0.017 0.00065	119.987 4.7239	119.967 4.7231	0.013 0.0005	0.017 0.00065
126, 226, 326	130.000 5.1181	129.975 5.1171	130.020 5.1189	130.002 5.1182	0.024 0.0010	0.019 0.00075	129.984 5.1175	129.962 5.1166	0.014 0.00055	0.019 0.00075
128, 228, 328	140.000 5.5118	139.975 5.5108	140.020 5.5126	140.002 5.5119	0.024 0.0010	0.019 0.00075	139.984 5.5112	139.962 5.5103	0.014 0.00055	0.019 0.00075
9130, 130, 230, 330	150.000 5.9055	149.975 5.9045	150.020 5.9063	150.002 5.9056	0.024 0.0010	0.019 0.00075	149.984 5.9049	149.962 5.9040	0.014 0.00055	0.019 0.00075
9132, 132, 232	160.000 6.2992	159.975 6.2982	160.020 6.3000	160.002 6.2993	0.024 0.0010	0.019 0.00075	159.984 6.2986	159.962 6.2977	0.014 0.00055	0.019 0.00075
9134, 134, 234	170.000 6.6929	169.975 6.6919	170.020 6.6937	170.002 6.6930	0.024 0.0010	0.019 0.00075	169.984 6.6923	169.962 6.6914	0.014 0.00055	0.019 0.00075
9136, 136, 236, 336	180.000 7.0866	179.975 7.0856	180.020 7.0874	180.002 7.0867	0.024 0.0010	0.019 0.00075	179.984 7.0860	179.962 7.0851	0.014 0.00055	0.019 0.00075
9138, 138, 238, 338	190.000 7.4803	189.970 7.4791	190.025 7.4813	190.005 7.4805	0.030 0.0012	0.024 0.00095	189.984 7.4797	189.956 7.4786	0.014 0.00055	0.020 0.0008
9140, 240, 340	200.000 7.8740	199.969 7.8728	200.025 7.8750	200.005 7.8742	0.030 0.0012		199.984 7.8734	199.954 7.8722	0.015 0.0006	
9142, 240, 340	210.000 8.2677	212.509 8.2665	209.771 8.2587	210.002 8.2678	0.030 0.0012		209.987 8.2672	209.951 8.2658	0.015 0.0006	
9144, 244, 344	220.000 8.6614	219.969 8.6602	220.025 8.6624	220.005 8.6616	0.030 0.0012		219.984 8.6608	219.954 8.6596	0.015 0.0006	
9146, 246	230.000 9.0551	229.969 9.0539	230.025 9.0561	230.005 9.0553	0.030 0.0012		230.022 9.0545	229.951 9.0533	0.015 0.0006	
248, 348	240.000 9.4488	239.969 9.4476	240.025 9.4498	240.005 9.4490	0.030 0.0012		239.984 9.4482	239.954 9.4470	0.015 0.0006	
250	250.000 9.8425	249.964 9.8411	250.020 9.8434	250.005 9.8426	0.030 0.0012		250.022 9.8418	249.972 9.8406	0.015 0.0006	
9152, 252, 352	260.000 10.2362	259.964 10.2348	260.027 10.2373	260.005 10.2364	0.036 0.0014		259.982 10.2355	259.951 10.2343	0.015 0.0006	
9156, 256, 356	280.000 11.0236	279.964 11.0222	280.027 11.0247	280.005 11.0238	0.036 0.0014		279.982 11.0229	279.951 11.0217	0.015 0.0006	
9160, 260	300.000 11.8110	299.964 11.8096	300.027 11.8121	300.005 11.8112	0.036 0.0014		299.982 11.8103	299.951 11.8091	0.015 0.0006	
9164, 264	320.000 12.5984	319.964 12.5970	320.030 12.5996	320.005 12.5986	0.038 0.0015		319.982 12.5977	319.946 12.5963	0.015 0.0006	
9180	400.000 15.7480	399.969 15.7464	400.030 15.7492	400.005 15.7482	0.038 0.0015		399.982 15.7473	399.946 15.7459	0.015 0.0006	



Radial ball bearing: shaft fits, ABEC-1 (ISO P0), ABEC-3 (ISO P6)

Bearing Bore Number	Bearing Bore, Diameter		Shaft Rotating, Load Stationary, Shaft Diameter		Mean Tight Fit
	Max.	Min.	Max.	Min.	
	mm in.	mm in.	mm in.	mm in.	
00	10.000 0.3937	9.992 0.3934	9.997 0.3936	10.005 0.3939	0.005 0.0002
01	12.000 0.4724	11.991 0.4721	11.996 0.4723	12.004 0.4726	0.005 0.0002
02	15.000 0.5906	14.994 0.5903	14.999 0.5905	15.006 0.5908	0.005 0.0002
03	17.000 0.6693	16.993 0.6690	16.998 0.6692	17.005 0.6695	0.005 0.0002
04	20.000 0.7874	19.992 0.7871	19.997 0.7873	20.005 0.7876	0.005 0.0002
05	25.000 0.9843	24.994 0.9840	24.999 0.9842	25.006 0.9845	0.005 0.0002
06	30.000 1.1811	29.992 1.1808	29.997 1.1810	30.005 1.1813	0.005 0.0002
07	35.000 1.3780	34.994 1.3777	34.999 1.3779	35.009 1.3783	0.006 0.00025
08	40.000 1.5748	39.992 1.5745	39.997 1.5747	40.008 1.5751	0.006 0.00025
09	45.000 1.7717	44.994 1.7714	44.999 1.7716	45.009 1.7720	0.006 0.00025
10	50.000 1.9685	49.992 1.9682	49.997 1.9684	50.008 1.9688	0.006 0.00025
11	55.000 2.1654	54.991 2.165	54.999 2.1653	55.011 2.1658	0.009 0.00035
12	60.000 2.3622	59.990 2.3618	59.997 2.3621	60.010 2.3626	0.009 0.00035
13	65.000 2.5591	64.991 2.5587	64.999 2.5590	65.011 2.5595	0.009 0.00035
14	70.000 2.7559	69.990 2.7555	69.997 2.7558	70.010 2.7563	0.009 0.00035
15	75.000 2.9528	74.991 2.9524	74.999 2.9527	75.011 2.9532	0.009 0.00035
16	80.000 3.1496	79.990 3.1492	79.997 3.1495	80.010 3.1500	0.009 0.00035
17	85.000 3.3465	84.988 3.3460	84.999 3.3464	85.014 3.3470	0.011 0.00045
18	90.000 3.5433	89.987 3.5428	89.997 3.5432	90.013 3.5438	0.011 0.00045
19	95.000 3.7402	94.988 3.7397	94.999 3.7401	95.014 3.7407	0.011 0.00045
20	100.000 3.9370	99.987 3.9365	99.997 3.9369	100.013 3.9375	0.011 0.00045
21	105.000 4.1339	104.988 4.1334	104.999 4.1338	105.014 4.1344	0.011 0.00045
22	110.000 4.3307	109.987 4.3302	109.997 4.3306	110.012 4.3312	0.011 0.00045
24	120.000 4.7244	119.987 4.7239	119.997 4.7243	120.012 4.7249	0.011 0.00045
26	130.000 5.1181	129.982 5.1174	129.997 5.118	130.015 5.1187	0.015 0.0006
28	140.000 5.5118	139.982 5.5111	139.997 5.5117	140.015 5.5124	0.015 0.0006
30	150.000 5.9055	149.982 5.9048	149.997 5.9054	150.015 5.9061	0.015 0.0006

J

Shaft and housing shoulder

Shaft fits, 7000WN single row angular contact bearings

Bearing Bore Number	Bearing Bore, Diameter		These diameters result in shaft to bearing bore fit which closely conforms to j5 listed on pages 40-45.		Mean Tight Fit
			Shaft Rotating, Load Stationary, Shaft Diameter		
	Max.	Min.	Min.	Max.	
	mm in.	mm in.	mm in.	mm in.	
00	10.000 0.3937	9.992 0.3934	9.997 0.3936	10.005 0.3939	0.005 0.0002
01	12.000 0.4724	11.991 0.4721	11.996 0.4723	12.004 0.4726	0.005 0.0002
02	15.000 0.5906	14.994 0.5903	14.999 0.5905	15.006 0.5908	0.005 0.0002
03	17.000 0.6693	16.993 0.6690	16.998 0.6692	17.005 0.6695	0.005 0.0002
04	20.000 0.7874	19.992 0.7871	19.997 0.7873	20.005 0.7876	0.005 0.0002
05	25.000 0.9843	24.994 0.9840	24.999 0.9842	25.006 0.9845	0.005 0.0002
06	30.000 1.1811	29.992 1.1808	29.997 1.1810	30.005 1.1813	0.005 0.0002
07	35.000 1.3780	34.994 1.3777	34.999 1.3779	35.009 1.3783	0.006 0.00025
08	40.000 1.5748	39.992 1.5745	39.997 1.5747	40.008 1.5751	0.006 0.00025
09	45.000 1.7717	44.994 1.7714	44.999 1.7716	45.009 1.7720	0.006 0.00025
10	50.000 1.9685	49.992 1.9682	49.997 1.9684	50.008 1.9688	0.006 0.00025
11	55.000 2.1654	54.991 2.1650	54.999 2.1653	55.011 2.1658	0.009 0.00035
12	60.000 2.3622	59.990 2.3618	59.997 2.3621	60.010 2.3626	0.009 0.00035
13	65.000 2.5591	64.991 2.5587	64.999 2.5590	65.011 2.5595	0.009 0.00035
14	70.000 2.7559	69.990 2.7555	69.997 2.7558	70.010 2.7563	0.009 0.00035
15	75.000 2.9528	74.991 2.9524	74.999 2.9527	75.011 2.9532	0.009 0.00035
16	80.000 3.1496	79.990 3.1492	79.997 3.1495	80.010 3.1500	0.009 0.00035
17	85.000 3.3465	84.988 3.3460	84.999 3.3464	85.014 3.3470	0.011 0.00045
18	90.000 3.5433	89.987 3.5428	89.997 3.5432	90.013 3.5438	0.011 0.00045
19	95.000 3.7402	94.988 3.7397	94.999 3.7401	95.014 3.7407	0.011 0.00045
20	100.000 3.9370	99.987 3.9365	99.997 3.9369	100.013 3.9375	0.011 0.00045
21	105.000 4.1339	104.988 4.1334	104.999 4.1338	105.014 4.1344	0.011 0.00045
22	110.000 4.3307	109.987 4.3302	109.997 4.3306	110.012 4.3312	0.011 0.00045
24	120.000 4.7244	119.987 4.7239	119.997 4.7243	120.012 4.7249	0.011 0.00045
26	130.000 5.1181	129.982 5.1174	129.997 5.1180	130.015 5.1187	0.015 0.0006
28	140.000 5.5118	139.982 5.5111	139.997 5.5117	140.015 5.5124	0.015 0.0006
30	150.000 5.9055	149.982 5.9048	149.997 5.9054	150.015 5.9061	0.015 0.0006



Radial ball bearing: housing fits, ABEC-1 (ISO P0), ABEC-3 (ISO P6)

Basic Bearing Number					Housing Stationary, Load Stationary or Housing Rotating, Load Rotating				Housing Rotating, Load Stationary or Housing Stationary, Load Rotating			
Extra Small	Extra Light	Light	Medium	Heavy	Housing Bore		Mean Fit Loose		Housing Bore		Mean Fit Tight	
30, S, F Series	9100, 9300 Series	200, 7200 Series	300, 7300 Series	7400 Series	Max.	Min.	ABEC-1	ABEC-3	Max.	Min.	ABEC-1	ABEC-3
					mm in.		mm in.		mm in.		mm in.	
33K3, F33K3	-	-	-	-	9.535 0.3754	9.525 0.3750	0.010 0.00040	0.009 0.00035	9.525 0.3750	9.507 0.3743	0.004 0.00015	0.005 0.00020
33K4	-	-	-	-	12.710 0.5004	12.700 0.5000	0.010 0.00040	0.009 0.00035	12.700 0.5000	12.682 0.4993	0.004 0.00015	0.005 0.00020
33K5, F33K5	-	-	-	-	12.710 0.5004	12.700 0.5000	0.010 0.00040	0.009 0.00035	12.700 0.5000	12.682 0.4993	0.004 0.00015	0.005 0.00020
34K	-	-	-	-	16.010 0.6303	15.999 0.6299	0.010 0.00040	0.009 0.00035	15.999 0.6299	15.982 0.6292	0.004 0.00015	0.005 0.00020
35K	-	-	-	-	19.012 0.7485	18.999 0.7480	0.011 0.00045	0.010 0.00040	18.999 0.7480	18.979 0.7472	0.005 0.00020	0.006 0.00025
36K	-	-	-	-	19.012 0.7485	18.999 0.7480	0.011 0.00045	0.010 0.00040	18.999 0.7480	18.979 0.7472	0.005 0.00020	0.006 0.00025
37K	-	-	-	-	22.012 0.8666	21.999 0.8661	0.011 0.00045	0.010 0.00040	21.999 0.8661	21.979 0.8653	0.005 0.00020	0.006 0.00025
38K	-	-	-	-	22.012 0.8666	21.999 0.8661	0.011 0.00045	0.010 0.00040	21.999 0.8661	21.979 0.8653	0.005 0.00020	0.006 0.00025
38KV	-	-	-	-	24.013 0.9454	24.000 0.9449	0.011 0.00045	0.010 0.00040	24.000 0.9449	23.980 0.9441	0.005 0.00020	0.006 0.00025
39K	9100	-	-	-	26.012 1.0241	25.999 1.0236	0.011 0.00045	0.010 0.00040	25.999 1.0236	25.979 1.0228	0.005 0.00020	0.006 0.00025
S1K7, FS1K7	-	-	-	-	15.885 0.6254	15.875 0.6250	0.010 0.00040	0.009 0.00035	15.875 0.6250	15.857 0.6243	0.004 0.00015	0.005 0.00020
S1K	-	-	-	-	19.063 0.7505	19.050 0.7500	0.011 0.00045	0.010 0.00040	19.050 0.7500	19.030 0.7492	0.005 0.00020	0.006 0.00025
S3K, FS3K	-	-	-	-	22.238 0.8755	22.225 0.8750	0.011 0.00045	0.010 0.00040	22.225 0.8750	22.205 0.8742	0.005 0.00020	0.006 0.00025
S5K	-	-	-	-	28.588 1.1255	28.575 1.1250	0.011 0.00045	0.010 0.00040	28.575 1.1250	28.555 1.1242	0.005 0.00020	0.006 0.00025
S7K	-	-	-	-	34.940 1.3756	34.925 1.3750	0.014 0.00055	0.011 0.00045	34.925 1.3750	34.900 1.3740	0.006 0.00025	0.009 0.00035
S8K	-	-	-	-	41.290 1.6256	41.275 1.6250	0.014 0.00055	0.011 0.00045	41.275 1.6250	41.250 1.6240	0.006 0.00025	0.009 0.00035
S9K	-	-	-	-	47.640 1.8756	47.625 1.8750	0.014 0.00055	0.011 0.00045	47.625 1.8750	47.600 1.8740	0.006 0.00025	0.009 0.00035
S10K	-	-	-	-	50.818 2.0007	50.800 2.0000	0.015 0.00060	0.014 0.00055	50.800 2.0000	50.770 1.9988	0.009 0.00035	0.010 0.00040
S11K	-	-	-	-	53.993 2.1257	53.975 2.1250	0.015 0.00060	0.014 0.00055	53.975 2.1250	53.945 2.1238	0.009 0.00035	0.010 0.00040
S12K	-	-	-	-	57.168 2.2507	57.150 2.2500	0.015 0.00060	0.014 0.00055	57.150 2.2500	57.120 2.2488	0.009 0.00035	0.010 0.00040
F2002	-	-	-	-	9.533 0.3753	9.525 0.3750	0.000 0.00000	0.000 0.00000	9.533 0.3753	9.522 0.3749	0.000 0.00000	0.000 0.00000
F2	-	-	-	-	11.120 0.4378	11.112 0.4375	0.000 0.00000	0.000 0.00000	11.120 0.4378	11.110 0.4374	0.000 0.00000	0.000 0.00000
F3	-	-	-	-	14.295 0.5628	14.285 0.5624	0.000 0.00000	0.000 0.00000	14.295 0.5628	14.285 0.5624	0.000 0.00000	0.000 0.00000

J

Basic Bearing Number					Housing Stationary, Load Stationary or Housing Rotating, Load Rotating				Housing Rotating, Load Stationary or Housing Stationary, Load Rotating			
Extra Small	Extra Light	Light	Medium	Heavy	Housing Bore		Mean Fit Loose		Housing Bore		Mean Fit Tight	
30, S, F Series	9100, 9300 Series	200, 7200 Series	300, 7300 Series	7400 Series	Max	Min	ABEC-1	ABEC-3	Max	Min	ABEC-1	ABEC-3
					mm in.	mm in.	mm in.	mm in.	mm in.	mm in.		
F4	–	–	–	–	15.883 0.6253	15.872 0.6249	0.000 0.00000	0.000 0.00000	15.883 0.6253	15.872 0.6249	0.000 0.00000	0.000 0.00000
F5	–	–	–	–	17.470 0.6878	17.460 0.6874	0.000 0.00000	0.000 0.00000	17.476 0.6878	17.460 0.6874	0.000 0.00000	0.000 0.00000
–	9101, 9302	–	–	–	28.014 1.1029	28.001 1.1024	0.011 0.00045	0.010 0.00040	28.001 1.1024	27.981 1.1016	0.005 0.00020	0.006 0.00025
–	9303	200	–	–	30.013 1.1816	30.000 1.1811	0.011 0.00045	0.010 0.00040	39.000 1.1811	29.980 1.1803	0.005 0.00020	0.006 0.00025
–	9102	201	–	–	32.014 1.2604	31.999 1.2598	0.014 0.00055	0.011 0.00045	31.999 1.2598	31.974 1.2588	0.006 0.00025	0.009 0.00035
–	9103	202	300	–	35.016 1.3786	35.001 1.3780	0.014 0.00055	0.011 0.00045	35.001 1.3780	34.976 1.3770	0.006 0.00025	0.009 0.00035
–	9304	–	301	–	37.015 1.4573	37.000 1.4567	0.014 0.00055	0.011 0.00045	37.000 1.4567	36.975 1.4557	0.006 0.00025	0.009 0.00035
–	–	203	–	–	40.015 1.5754	40.000 1.5748	0.014 0.00055	0.011 0.00045	40.000 1.5748	39.975 1.5738	0.006 0.00025	0.009 0.00035
–	9104, 9305	–	302	–	42.014 1.6541	41.999 1.6535	0.014 0.00055	0.011 0.00045	41.999 1.6535	41.974 1.6525	0.006 0.00025	0.009 0.00035
–	9105, 9306	204	303	–	47.015 1.8510	47.000 1.8504	0.014 0.00055	0.011 0.00045	47.000 1.8504	46.975 1.8494	0.006 0.00025	0.009 0.00035
–	–	205	304	–	52.017 2.0479	51.999 2.0472	0.015 0.00060	0.014 0.00055	51.999 2.0472	51.968 2.0460	0.009 0.00035	0.010 0.00040
–	9106, 9307	–	–	–	55.019 2.1661	55.001 2.1654	0.015 0.00060	0.014 0.00055	55.001 2.1654	54.971 2.1642	0.009 0.00035	0.010 0.00040
–	9107, 9308	206	305	403	62.017 2.4416	61.999 2.4409	0.015 0.00060	0.014 0.00055	61.999 2.4409	61.968 2.4397	0.009 0.00030	0.010 0.00040
–	9108	–	–	–	68.019 2.6779	68.001 2.6772	0.015 0.00060	0.014 0.00055	68.001 2.6772	67.970 2.6760	0.009 0.00030	0.010 0.00040
–	9310	207	306	404	72.017 2.8353	71.999 2.8346	0.015 0.00060	0.014 0.00055	71.999 2.8346	71.968 2.8334	0.009 0.00030	0.010 0.00040
–	9109	–	–	–	75.019 2.9535	75.001 2.9528	0.015 0.00060	0.014 0.00055	75.001 2.9528	74.971 2.9516	0.009 0.00030	0.010 0.00040
–	9110	208	307	405	80.018 3.1503	80.000 3.1496	0.015 0.00060	0.014 0.00055	80.000 3.1496	79.969 3.1484	0.009 0.00030	0.010 0.00040
–	9312	209	–	–	85.024 3.3474	85.001 3.3456	0.019 0.00080	0.017 0.00065	85.001 3.3465	84.966 3.3451	0.010 0.00040	0.013 0.00050
–	9111	210	308	406	90.023 3.5442	90.000 3.5433	0.019 0.00080	0.017 0.00065	90.000 3.5433	89.964 3.5419	0.010 0.00040	0.013 0.00050
–	9112	–	–	–	120.424 3.7411	95.001 3.7402	0.019 0.00080	0.017 0.00065	95.001 3.7402	94.965 3.7388	0.010 0.00040	0.013 0.00050
–	9113	211	309	407	100.023 3.9379	100.000 3.9370	0.019 0.00080	0.017 0.00065	100.000 3.9370	99.964 3.9356	0.010 0.00040	0.013 0.00050
–	9114	212	310	408	110.023 4.3316	110.000 4.3307	0.019 0.00080	0.017 0.00065	110.000 4.3307	109.964 4.3293	0.010 0.00040	0.013 0.00050



Radial ball bearing: housing fits, ABEC-1 (ISO P0), ABEC-3 (ISO P6)

Basic Bearing Number					Housing Stationary, Load Stationary or Housing Rotating, Load Rotating				Housing Rotating, Load Stationary or Housing Stationary, Load Rotating			
Extra Small	Extra Light	Light	Medium	Heavy	Housing Bore		Mean Fit Loose		Housing Bore		Mean Fit Tight	
30, S, F Series	9100, 9300 Series	200, 7200 Series	300, 7300 Series	7400 Series	Max.	Min.	ABEC-1	ABEC-3	Max.	Min.	ABEC-1	ABEC-3
					mm in.		mm in.		mm in.		mm in.	
-	9115	-	-	-	115.024 4.5285	115.001 4.5276	0.019 0.0008	0.017 0.00065	115.001 4.5276	114.965 4.5262	0.010 0.0004	0.013 0.00050
-	-	213	311	409	120.023 4.7253	120.000 4.7244	0.019 0.0008	0.017 0.00065	120.000 4.7244	119.964 4.7230	0.010 0.0004	0.013 0.00050
-	-	214	-	-	125.026 4.9223	125.001 4.9213	0.023 0.0009	0.019 0.00075	125.001 4.9213	124.960 4.9197	0.010 0.0004	0.014 0.00055
-	9117	215	312	410	130.025 5.1191	130.000 5.1181	0.023 0.0009	0.019 0.00075	130.000 5.1181	129.959 5.1165	0.010 0.0004	0.014 0.00055
-	9118	216	313	411	140.025 5.5128	140.000 5.5118	0.023 0.0009	0.019 0.00075	140.000 5.5118	139.959 5.5102	0.010 0.0004	0.014 0.00055
-	9120	217	314	412	150.025 5.9065	150.000 5.9055	0.023 0.0009	0.019 0.00075	150.000 5.9055	149.959 5.9039	0.010 0.0004	0.014 0.00055
-	120-2	218	315	-	160.025 6.3002	160.000 6.2992	0.025 0.0010	0.020 0.00080	160.000 6.2992	159.959 6.2976	0.008 0.0003	0.013 0.00050
-	9121	-	-	413	160.025 6.3002	160.000 6.2992	0.025 0.0010	0.020 0.00080	160.000 6.2992	159.959 6.2976	0.008 0.0003	0.013 0.00050
-	9122	129	316	-	170.025 6.6939	170.000 6.6929	0.025 0.0010	0.020 0.00080	170.000 6.6929	169.959 6.6913	0.008 0.0003	0.013 0.00050
-	122	-	-	-	175.026 6.8908	175.000 6.8898	0.025 0.0010	0.020 0.00080	175.001 6.8898	174.960 6.8882	0.008 0.0003	0.013 0.00050
-	9124	220	317	414	180.025 7.0876	180.000 7.0866	0.025 0.0010	0.020 0.00080	180.000 7.0866	179.959 7.0850	0.008 0.0003	0.013 0.00050
-	124	221	318	415	190.028 7.4815	190.000 7.4803	0.029 0.0012	0.023 0.00090	190.000 7.4803	189.954 7.4785	0.008 0.0003	0.014 0.00055
-	9126	222	319	416	200.028 7.8752	200.000 7.8740	0.029 0.0012	0.023 0.00090	200.000 7.8740	199.954 7.8722	0.008 0.0003	0.014 0.00055
-	126	-	-	-	205.029 8.0721	205.001 8.0709	0.029 0.0012	0.023 0.00090	205.001 8.0709	204.955 8.0691	0.008 0.0003	0.014 0.00055
-	9128	-	-	-	210.028 8.2689	210.000 8.2677	0.029 0.0012	0.023 0.00090	210.000 8.2677	209.954 8.2659	0.008 0.0003	0.014 0.00055
-	-	224	320	-	215.029 8.4658	215.001 8.4646	0.029 0.0012	0.023 0.00090	215.001 8.4646	214.955 8.4628	0.008 0.0003	0.014 0.00055
-	128	-	-	-	220.028 8.6626	220.000 8.6614	0.029 0.0012	0.023 0.00090	220.000 8.6614	219.954 8.6596	0.008 0.0003	0.014 0.00055
-	9130	-	321	418	225.029 8.8595	225.001 8.8583	0.029 0.0012	0.023 0.00090	225.001 8.8583	224.955 8.8565	0.008 0.0003	0.014 0.00055
-	-	226	-	-	230.027 9.0563	230.000 9.0551	0.029 0.0012	0.023 0.00090	230.000 9.0551	229.954 9.0533	0.008 0.0003	0.014 0.00055
-	130	-	-	-	235.029 9.2532	235.001 9.2520	0.029 0.0012	0.023 0.00090	235.001 9.2520	234.955 9.2502	0.008 0.0003	0.014 0.00055
-	9132	-	322	-	240.027 9.4506	240.000 9.4488	0.029 0.0012	0.023 0.00090	240.000 9.4488	239.954 9.4470	0.008 0.0003	0.014 0.00055



Basic Bearing Number					Housing Stationary, Load Stationary or Housing Rotating, Load Rotating				Housing Rotating, Load Stationary or Housing Stationary, Load Rotating			
Extra Small	Extra Light	Light	Medium	Heavy	Housing Bore		Mean Fit Loose		Housing Bore		Mean Fit Tight	
30, S, F Series	9100, 9300 Series	200, 7200 Series	300, 7300 Series	7400 Series	Max.	Min.	ABEC-1	ABEC-3	Max.	Min.	ABEC-1	ABEC-3
					mm in.	mm in.	mm in.	mm in.	mm in.	mm in.		
-	132	228	-	-	250.027 9.8437	250.000 9.8425	0.029 0.0012	0.023 0.00090	250.000 9.8425	249.954 9.8407	0.008 0.0003	0.014 0.00055
-	9134	-	324	-	260.032 10.2374	259.999 10.2362	0.033 0.0013	0.027 0.00105	259.999 10.2362	259.942 10.2342	0.008 0.0003	0.015 0.00060
-	134	-	-	420	265.034 10.4343	265.001 10.4331	0.033 0.0013	0.027 0.00105	265.001 10.4331	264.950 10.4311	0.008 0.0003	0.015 0.00060
-	-	230	-	-	270.032 10.6311	269.999 10.6299	0.033 0.0013	0.027 0.00105	269.999 10.6299	269.949 10.6279	0.008 0.0003	0.015 0.00060
-	136,9136	-	326	-	280.032 11.0248	279.999 11.0236	0.033 0.0013	0.027 0.00105	279.999 11.0236	279.949 11.0216	0.008 0.0003	0.015 0.00060
-	9138	232	-	-	290.039 11.4185	289.999 11.4173	0.033 0.0013	0.027 0.00105	289.999 11.4173	289.949 11.4153	0.008 0.0003	0.015 0.00060
-	138	-	328	-	300.032 11.8122	299.999 11.8110	0.033 0.0013	0.027 0.00105	299.999 11.8110	299.949 11.8090	0.008 0.0003	0.015 0.00060
-	9140	234	-	-	310.029 12.2059	309.999 12.2047	0.033 0.0013	-	309.999 12.2047	309.949 12.2027	0.008 0.0003	-
-	-	236	330	-	320.035 12.5998	319.999 12.5984	0.038 0.0015	-	319.999 12.5984	319.943 12.5962	0.008 0.0003	-
-	9144	238	-	-	340.035 13.3872	339.999 13.3858	0.038 0.0015	-	339.999 13.3858	339.943 13.3836	0.008 0.0003	-
-	9146	240	-	-	360.035 14.1746	359.999 14.1732	0.038 0.0015	-	359.999 14.1732	359.943 14.1710	0.008 0.0003	-
-	-	242	336	-	380.035 14.9620	380.007 14.9606	0.038 0.0015	-	379.999 14.9606	379.943 14.9584	0.008 0.0003	-
-	9152	244	338	-	400.035 15.7494	399.999 15.7480	0.038 0.0015	-	399.999 15.7480	399.943 15.7458	0.008 0.0003	-
-	9156	246	340	-	420.040 16.5370	419.999 16.5354	0.038 0.0017	-	419.999 16.5354	419.936 16.5329	0.010 0.0004	-
-	-	248	342	-	440.040 17.3244	439.999 17.3228	0.038 0.0017	-	439.999 17.3228	439.936 17.3203	0.010 0.0004	-
-	9160	250	344	-	460.040 18.1118	459.999 18.1102	0.038 0.0017	-	459.999 18.1102	459.936 18.1077	0.010 0.0004	-
-	9164	252	-	-	480.040 18.8992	479.999 18.8976	0.038 0.0017	-	479.999 18.8976	479.936 18.8951	0.010 0.0004	-
-	-	256	348	-	500.040 19.6866	499.999 19.6850	0.038 0.0017	-	499.999 19.6850	499.936 19.6825	0.010 0.0004	-
-	-	260	352	-	540.042 21.2615	539.999 21.2598	0.048 0.0019	-	539.999 21.2598	539.930 21.2571	0.010 0.0004	-
-	-	264	356	-	580.042 22.8363	579.999 22.8346	0.048 0.0019	-	579.999 22.8346	579.930 22.8319	0.010 0.0004	-
-	9180	-	-	-	600.042 23.6237	599.999 23.6220	0.048 0.0019	-	599.999 23.6220	599.930 23.6193	0.010 0.0004	-



BALL BEARINGS

These charts provide guidelines for shaft and housing fits under specific operating conditions. Shaft and housing shoulders for radial ball bearings are shown here. Shaft and housing shoulder diameters for radial roller and thrust ball bearings are found in the respective dimension tables.

Numerical values for these tolerance symbols can be found in the Shaft and Housing Tolerances Section beginning on page 37.

Shaft

Ball Bearings (For All Nominal Diameters)				
Loads		Shaft Tolerance Symbol	Operating Conditions	Examples
Lower Load Limit	Upper Load Limit			
Inner ring stationary				
0	$C_e^{(2)}$	g6	Inner ring to be easily displaced on shaft	Wheels Non-rotating shafts
0	C_e	h6	Inner ring does not need to be easily displaced	Tension pulleys
Inner Ring Rotating, or Indeterminate				
0	$0.07C_e$	j6 ⁽³⁾	Light loads	Electrical apparatus Machine tools Pumps Ventilators Industrial trucks
$0.07C_e$	$0.15C_e$	k5	Normal loads	Electrical motors Turbines Pumps Combustion engines Gear transmissions
$0.15C_e$	C_e	m5	Heavy loads Shock loads	Rail vehicles Traction motors
Thrust loads				
0	C_e	j6 ⁽¹⁾	Pure thrust loads	All

⁽¹⁾ Bearings with greater than nominal clearance must be used.

⁽²⁾ C_e = Extended Dynamic Load Rating.

⁽³⁾ Use j5 for accurate applications.

Housing

Operating Conditions	Examples	Housing Tolerance Symbol ⁽¹⁾	Outer Ring Displaceable Axially	
Outer Ring Rotating				
Heavy loads with thin-wall housing	Crane support wheels Wheel hubs (roller bearings) Crank bearings	P6	No	
Normal to heavy loads	Wheel hubs (ball bearings) Crank bearings	N6	No	
Light loads	Conveyor rollers Rope sheaves Tension pulleys	M6	No	
Indeterminate Load Direction				
Heavy shock loads	Electric traction motors	M7	No	
Normal to heavy loads, axial displacement of outer ring not required	Electric motors Pumps Crankshaft main bearings	K6	No, normally	
Light to normal loads, axial displacement of outer ring desired	Electric motors Pumps Crankshaft main bearings	J6	Yes, normally	
Outer Ring Stationary				
Shock loads, temporary complete unloading	Heavy rail vehicles	J6	Yes, normally	
All Loads	One-piece housing	General applications Heavy rail vehicles	H6	Easily
	Radially split housing	Transmission drives	H7	Easily
Heat supplied through shaft	Dryer cylinders	G7	Easily	

⁽¹⁾ For cast iron or steel housing. See pages 46-53 for numerical values.

* Below this line, housing can either be one piece or split; above this line, a split housing is not suggested.

J

Shaft and housing shoulders - extra small series

These tables give the suggested maximum and minimum shaft and housing shoulder diameters for most applications. Where design limitations do not permit conformance to the suggested diameters, contact your Timken representative.

Extra light 9300 extra-small series

Basic Bearing Number	Shaft Shoulder ±0.25 mm ±.010 in.	Housing Shoulder ±0.25 mm ±.010 in.
	mm in.	mm in.
9301K	14.7 0.58	21.6 0.85
9302K	17.8 0.70	25.4 1.00
9303K	19.8 0.78	27.4 1.08
9304K	23.9 0.94	33.5 1.32
9305K	29.0 1.14	38.6 1.52
9306K	33.5 1.32	43.4 1.71
9307K	39.6 1.56	50.8 2.00
9308K	45.0 1.77	57.4 2.26
9309K	50.3 1.98	63.2 2.49
9310K	54.9 2.16	67.6 2.66
9311K	61.0 2.40	74.7 2.94
9312K	65.8 2.59	79.8 3.14

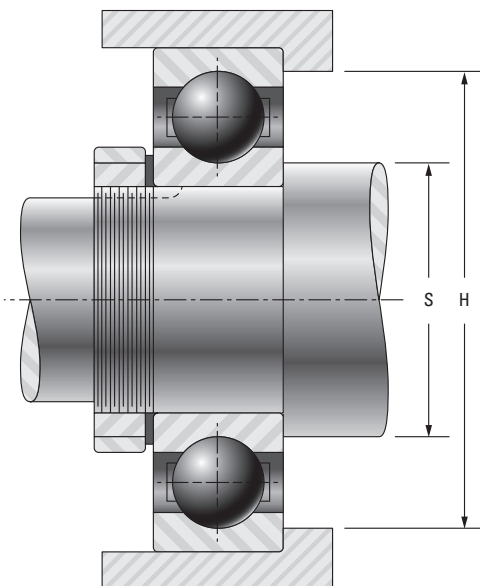

Fig. 45. Extra small series.

Shaft and housing diameters for radial ball bearings are shown here. Diameters for cylindrical, spherical and tapered roller bearings are found in the respective dimension tables.

Housing shoulders for wide inner ring bearings are shown on page 140.

Extra-small series

Basic Bearing Number	Shoulder Diameters			
	Shaft, S		Housing, H	
	Max.	Min.	Max.	Min.
	mm in.		mm in.	
33K3	5.1 0.20	4.8 0.19	8.1 0.32	7.9 0.31
33K4	6.1 0.24	5.8 0.23	11.2 0.44	10.9 0.43
33K5	6.6 0.26	6.4 0.25	11.2 0.44	10.9 0.43
34K	6.6 0.26	6.4 0.25	14.2 0.56	14.0 0.55
35K	9.4 0.37	9.1 0.36	17.0 0.67	16.8 0.66
36K	9.4 0.37	9.1 0.36	17.0 0.67	16.8 0.66
37K	11.2 0.44	10.7 0.42	20.1 0.79	19.6 0.77
38K	11.4 0.45	10.9 0.43	20.1 0.79	19.6 0.77
38KV	11.4 0.45	10.9 0.43	20.1 0.79	19.6 0.77
39K	13.0 0.51	12.5 0.49	23.1 0.91	22.6 0.89
S1K7	8.6 0.34	8.1 0.32	14.2 0.56	13.7 0.54
S1K	9.4 0.37	8.9 0.35	17.5 0.69	17.0 0.67
S3K	12.7 0.50	12.2 0.48	20.3 0.80	19.8 0.78
S5K	16.0 0.63	15.5 0.61	25.1 0.99	24.6 0.97
S7K	21.3 0.84	20.3 0.80	31.5 1.24	30.5 1.20
S8K	24.6 0.97	23.6 0.93	37.1 1.46	35.6 1.40
S9K	28.9 1.14	27.9 1.10	41.9 1.65	40.9 1.61
S10K	31.5 1.24	30.5 1.20	46.7 1.84	45.7 1.80
S11K	34.0 1.34	33.0 1.30	49.5 1.95	48.5 1.91
S12K	39.4 1.55	38.4 1.51	55.9 2.20	50.8 2.00



Shaft and housing shoulders - radial ball bearings

Extra-Light - 9100 Series					Light - 200, 5200, 7200WN Series					Medium - 300, 5300, 7300WN Series				
Basic Bearing Number	Shoulder Diameters				Basic Bearing Number	Shoulder Diameters				Basic Bearing Number	Shoulder Diameters			
	Shaft, S		Housing, H			Shaft, S		Housing, H			Shaft, S		Housing, H	
	Max.	Min.	Max.	Min.		Max.	Min.	Max.	Min.		Max.	Min.	Max.	Min.
	mm in.		mm in.			mm in.		mm in.			mm in.		mm in.	
9100	13.20 0.52	11.90 0.47	24.10 0.95	23.10 0.91	200	14.20 0.56	12.70 0.50	24.90 0.98	24.60 0.97	300	15.00 0.59	12.70 0.50	30.00 1.18	29.20 1.15
9101	18.00 0.71	14.00 0.55	25.90 1.02	24.60 0.97	201	16.30 0.64	14.70 0.58	26.90 1.06	26.70 1.05	301	17.50 0.69	16.00 0.63	31.00 1.22	30.70 1.21
9102	19.00 0.75	17.00 0.67	30.00 1.18	28.70 1.13	202	19.00 0.75	17.50 0.69	30.00 1.18	29.20 1.15	302	20.60 0.81	19.00 0.75	36.10 1.42	35.60 1.40
9103	20.60 0.81	19.00 0.75	33.00 1.30	31.80 1.25	203	21.30 0.84	19.60 0.77	34.00 1.34	33.30 1.31	303	23.10 0.91	21.10 0.83	40.90 1.61	40.60 1.60
9104	24.90 0.98	22.60 0.89	37.10 1.46	35.80 1.41	204	25.40 1.00	23.90 0.94	40.90 1.61	40.10 1.58	304	26.90 1.06	23.90 0.94	45.00 1.77	44.40 1.75
9105	30.00 1.18	27.40 1.08	41.90 1.65	40.60 1.60	205	31.00 1.22	29.00 1.14	46.00 1.81	45.20 1.78	305	33.30 1.31	29.00 1.14	55.10 2.17	53.10 2.09
9106	35.10 1.38	34.00 1.34	49.00 1.93	47.80 1.88	206	37.30 1.47	34.00 1.34	56.10 2.21	54.90 2.16	306	39.60 1.56	34.00 1.34	65.00 2.56	62.00 2.44
9107	41.40 1.63	38.90 1.53	56.10 2.21	54.60 2.15	207	43.70 1.72	38.90 1.53	65.00 2.56	62.70 2.47	307	45.20 1.78	42.90 1.69	71.10 2.80	69.10 2.72
9108	46.00 1.81	43.90 1.73	62.00 2.44	60.70 2.39	208	49.30 1.94	43.90 1.73	72.90 2.87	70.60 2.78	308	50.80 2.00	49.00 1.93	81.00 3.19	77.70 3.06
9109	51.60 2.03	49.30 1.94	69.10 2.72	67.80 2.67	209	54.10 2.13	49.30 1.94	78.00 3.07	75.40 2.97	309	52.28 2.05	51.10 2.01	81.00 3.19	77.70 3.06
9110	56.40 2.22	54.10 2.13	73.90 2.91	72.60 2.86	210	59.40 2.34	54.10 2.13	83.10 3.27	80.50 3.17	310	63.50 2.50	59.90 2.36	100.10 3.94	95.20 3.75
9111	63.00 2.48	59.20 2.33	83.10 3.27	81.80 3.22	211	64.50 2.54	61.20 2.41	93.50 3.68	90.40 3.56	311	69.80 2.75	65.00 2.56	110.00 4.33	104.90 4.13
9112	67.80 2.67	64.30 2.53	88.10 3.47	86.90 3.42	212	71.40 2.81	67.80 2.67	101.10 3.98	98.30 3.87	312	74.70 2.94	72.10 2.84	118.10 4.65	112.80 4.44
9113	72.10 2.84	69.10 2.72	93.00 3.66	91.70 3.61	213	77.00 3.03	72.60 2.86	111.00 4.37	106.40 4.19	313	81.00 3.19	77.00 3.03	128.00 5.04	122.20 4.81
9114	79.00 3.11	73.90 2.91	103.10 4.06	100.80 3.97	214	81.80 3.22	77.70 3.06	116.10 4.57	112.00 4.41	314	87.40 3.44	82.00 3.23	137.90 5.43	130.30 5.13
9115	84.10 3.31	79.00 3.11	108.00 4.25	105.70 4.16	215	87.40 3.44	82.60 3.25	120.90 4.76	116.60 4.59	315	98.60 3.88	87.10 3.43	148.10 5.83	139.70 5.50
9116	90.40 3.56	84.10 3.31	118.10 4.65	114.30 4.50	216	93.70 3.69	90.20 3.55	130.00 5.12	125.20 4.93	316	100.10 3.94	91.90 3.62	158.00 6.22	149.40 5.88
9117	95.20 3.75	88.90 3.50	122.90 4.84	119.60 4.71	217	98.60 3.88	95.20 3.75	140.00 5.51	134.90 5.31	317	104.90 4.13	99.10 3.90	166.10 6.54	157.20 6.19

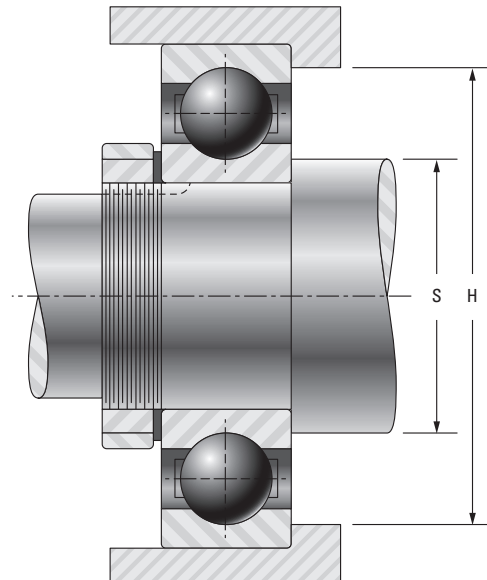

Fig. 46. Radial ball bearing.

Extra-Light - 9100 Series					Light - 200, 5200, 7200WN Series					Medium - 300, 5300, 7300WN Series				
Basic Bearing Number	Shoulder Diameters				Basic Bearing Number	Shoulder Diameters				Basic Bearing Number	Shoulder Diameters			
	Shaft, S		Housing, H			Shaft, S		Housing, H			Shaft, S		Housing, H	
	Max.	Min.	Max.	Min.		Max.	Min.	Max.	Min.		Max.	Min.	Max.	Min.
	mm in.		mm in.			mm in.		mm in.			mm in.		mm in.	
9118	102.40 4.03	97.50 3.84	131.10 5.16	130.30 5.13	218	105.70 4.16	100.10 3.94	150.10 5.91	142.70 5.62	318	111.30 4.38	103.90 4.09	176.00 6.93	165.10 6.50
9120	111.30 4.38	107.40 4.23	141.00 5.55	138.20 5.44	219	111.30 4.38	106.90 4.21	158.00 6.22	153.90 6.06	319	117.60 4.63	109.00 4.29	185.90 7.32	174.80 6.88
9121	118.40 4.66	115.10 4.53	150.10 5.91	146.00 5.75	220	117.60 4.63	112.00 4.41	167.90 6.61	160.30 6.31	320	124.00 4.88	114.00 4.49	200.90 7.91	187.40 7.38
9122	124.70 4.91	119.90 4.72	160.00 6.30	157.00 6.18	221	124.00 4.88	117.10 4.61	178.10 7.01	174.80 6.88	321	130.30 5.13	119.10 4.69	211.10 8.31	196.80 7.75
9124	134.10 5.28	130.00 5.12	169.90 6.69	165.10 6.50	222	130.30 5.13	121.90 4.80	188.00 7.40	179.30 7.06	322	139.70 5.50	124.00 4.88	226.10 8.90	209.60 8.25
9126	147.60 5.81	140.00 5.51	190.00 7.48	184.10 7.25	224	143.00 5.63	132.10 5.20	202.90 7.99	192.00 7.56	324	152.40 6.00	134.10 5.28	246.10 9.69	226.80 8.93
9128	153.90 6.06	147.60 5.81	200.20 7.88	195.10 7.68	226	152.40 6.00	144.00 5.67	215.90 8.50	206.50 8.13	326	163.60 6.44	148.10 5.83	262.10 10.32	246.10 9.69
9130	167.40 6.59	162.10 6.38	213.10 8.39	206.50 8.13	228	165.10 6.50	153.90 6.06	236.00 9.29	223.80 8.81	328	176.00 6.93	158.00 6.22	281.90 11.10	263.70 10.38
9132	176.80 6.96	166.60 6.56	228.60 9.00	222.20 8.75	230	177.00 6.97	164.10 6.46	256.00 10.08	241.30 9.50	330	189.00 7.44	167.90 6.61	302.00 11.89	280.90 11.06
9134	192.00 7.56	182.10 7.17	247.90 9.76	239.80 9.44	232	186.90 7.36	174.00 6.85	276.10 10.87	260.40 10.25	332	188.00 7.84	178.00 7.01	322.10 12.68	294.10 11.58
9138	212.90 8.38	201.90 7.95	278.10 10.95	266.70 10.50	234	202.70 7.98	188.00 7.40	292.10 11.50	276.40 10.88	334	213.40 8.40	188.00 7.40	342.10 13.47	311.70 12.27
9140	224.50 8.84	212.10 8.35	297.90 11.73	285.00 11.22	236	212.90 8.38	198.10 7.80	302.00 11.89	281.70 11.09	336	223.50 8.80	198.10 7.80	362.00 14.25	331.50 13.05
9144	246.40 9.70	233.90 9.21	326.10 12.84	310.90 12.24	238	222.80 8.77	208.00 8.19	322.10 12.68	301.80 11.88	338	237.50 9.35	212.10 8.35	378.20 14.89	345.20 13.59
9148	266.70 10.50	254.00 10.00	345.90 13.62	330.70 13.02	240	239.30 9.42	217.90 8.58	342.10 13.47	319.30 12.57	340	249.90 9.84	222.00 8.74	398.00 15.67	365.00 14.37
9152	291.80 11.49	278.10 10.95	382.00 15.04	366.80 14.44	242	246.10 9.69	225.30 8.87	362.20 14.26	336.80 13.26	342	260.10 10.24	232.20 9.14	418.30 16.47	385.30 15.17
9156	313.20 12.33	297.90 11.73	402.10 15.83	386.80 15.23	244	257.60 10.14	238.00 9.37	382.00 15.04	356.60 14.04	344	272.50 10.73	242.10 9.53	437.90 17.24	405.40 15.96
9160	339.30 13.36	318.00 12.52	442.00 17.40	421.60 16.60	246	268.70 10.58	247.90 9.76	402.10 15.83	370.80 14.60	348	292.60 11.52	262.10 10.32	478.00 18.82	439.90 17.32
9164	360.40 14.19	338.10 13.31	462.00 18.19	441.70 17.39	248	283.50 11.16	258.10 10.16	421.90 16.61	385.60 15.18	352	318.50 12.54	288.00 11.34	512.10 20.16	474.00 18.66
9180	457.20 18.00	431.80 17.00	561.80 22.12	549.10 21.62	250	293.40 11.55	268.00 10.55	442.00 17.40	398.80 15.70	356	341.10 13.43	308.10 12.13	551.90 21.73	511.30 20.13



Shaft and housing shoulder

Heavy 400, 7400 series

Basic Bearing Number	Shaft, S		Housing, H	
	Max.	Min.	Max.	Min.
	mm in.		mm in.	
7405	37.3 1.47	34.0 1.34	71.1 2.80	66.8 2.63
7406	43.7 1.72	39.1 1.54	81.0 3.19	76.2 3.00
7407	49.0 1.93	43.9 1.73	90.9 3.58	85.9 3.38
7408	55.6 2.19	50.0 1.97	100.1 3.94	93.7 3.69
7409	62.0 2.44	55.1 2.17	110.0 4.33	101.6 4.00
7410	68.3 2.69	62.0 2.44	118.1 4.65	111.3 4.38
7411	74.4 2.93	67.1 2.64	128.0 5.04	120.7 4.75
7412	81.0 3.19	72.1 2.84	137.9 5.43	130.3 5.13
7413	88.9 3.50	77.0 3.03	148.1 5.83	139.7 5.50
7414	93.7 3.69	84.1 3.31	166.1 6.54	155.7 6.13
7415	99.8 3.93	88.9 3.50	176.0 6.93	163.6 6.44
7416	104.9 4.13	94.0 3.70	185.9 7.32	173.0 6.81
7418	119.1 4.69	108.0 4.25	207.0 8.15	196.9 7.75
7420	131.3 5.17	119.9 4.72	233.9 9.21	223.3 8.79

Non-standard extra-large

Basic Bearing Number	Shoulder Diameters			
	Shaft, S		Housing, H	
	Max.	Min.	Max.	Min.
	mm in.		mm in.	
120W2	117.6 4.63	111.8 4.40	150.1 5.91	146.0 5.75
122W	124.7 4.91	120.1 4.73	162.8 6.41	158.8 6.25
124W	134.1 5.28	130.0 5.12	178.1 7.01	174.5 6.87
126W	147.8 5.82	139.7 5.50	193.0 7.60	185.7 7.31
128W	157.2 6.19	150.1 5.91	207.8 8.18	202.2 7.96
130W	167.4 6.59	162.1 6.38	223.0 8.78	216.2 8.51
132W	189.0 7.44	174.0 6.85	234.7 9.24	223.8 8.81
134W	191.0 7.52	185.2 7.29	249.7 9.83	244.1 9.61
136W	203.2 8.00	195.3 7.69	264.7 10.42	257.8 10.15
138W	214.4 8.44	205.2 8.08	284.7 11.21	276.1 10.87
224W	143.0 5.63	132.1 5.20	203.2 8.00	192.0 7.56
226	152.4 6.00	144.0 5.67	215.9 8.50	206.5 8.13
228	165.1 6.50	153.9 6.06	236.0 9.29	223.8 8.81
276-2	401.8 15.82	400.1 15.75	463.6 18.25	461.5 18.17

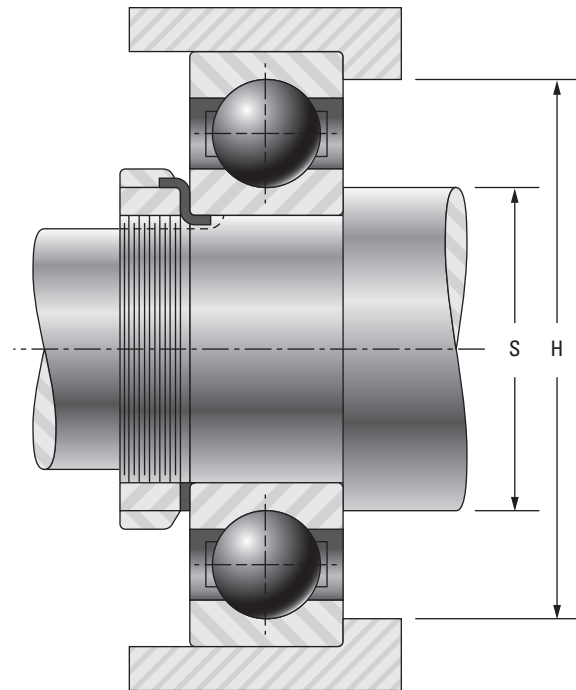

Fig. 47. Non standard extra large.

Shaft and housing shoulder

Mechani-Seal KL, KLD, KLL types

Housing shoulder diameters of bearings with Mechani-Seals differ slightly from those of other types to allow for clearance between the external rotating member of the seal and the housing shoulder.

Basic Bearing Number	Housing Shoulder Diameter, H	
	Max.	Min.
	mm in.	mm in.
36	17.0 0.67	16.8 0.66
36V	17.0 0.67	16.8 0.66
37	20.1 0.79	19.6 0.77
37V	20.1 0.79	19.6 0.77
34	20.1 0.79	19.6 0.77
38V	20.1 0.79	19.6 0.77
39	23.1 0.91	22.6 0.89
39V	23.1 0.91	22.6 0.89
200	27.7 1.09	26.2 1.03
201	29.5 1.16	27.7 1.09
20-2	29.5 1.16	27.7 1.09
201-3	29.5 1.16	27.7 1.09
202	32.5 1.28	31.0 1.22
202-2	32.5 1.28	31.0 1.22
202-3	32.5 1.28	31.0 1.22
202-4	32.5 1.28	31.0 1.22
203	36.6 1.44	35.8 1.41
204	43.7 1.72	41.1 1.62
204-2	43.7 1.72	41.1 1.62
205	48.5 1.91	46.7 1.84
205-2	48.5 1.91	46.7 1.84
206	57.9 2.28	56.4 2.22
207	67.6 2.66	64.3 2.53
208	75.4 2.97	71.4 2.81
209	80.3 3.16	77.0 3.03
209-2	80.3 3.16	77.0 3.03
211	93.7 3.69	90.4 3.56

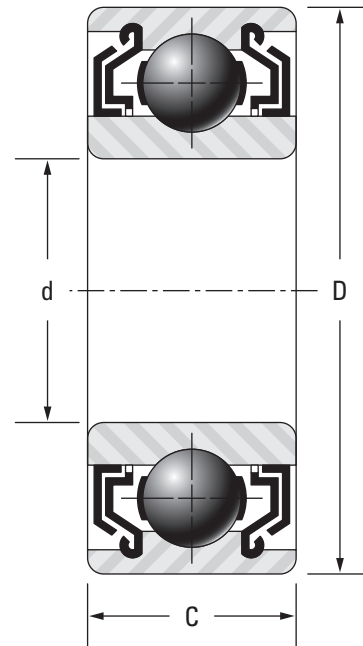

Fig. 48. Mechani-Seal KL, KLD, KLL types.



Shaft and housing considerations

When selecting shafts for use with wide inner ring bearings, a minimum slip fit is desirable for the most satisfactory mounting. Special shaft limits are required in certain cases, and a variety of standard fits can be used, even including a press fit.

The suggested figures are noted below, but in some applications it may be permissible to use increased shaft tolerances. Contact your Timken representative for recommendations.

Bearing bore tolerance

$1/2$ in. - $2 \frac{3}{16}$ in. = nominal to +.013 mm (+.0005 in.)

$2 \frac{1}{4}$ in. - $3 \frac{3}{16}$ in. = nominal to +.015 mm (+.0006 in.)

$3 \frac{7}{16}$ in. - $3 \frac{15}{16}$ in. = nominal to +.018 mm (+.0007 in.)

Suggested shaft tolerances

$1/2$ in. - $1 \frac{15}{16}$ in. = nominal to -.013 mm (-.0005 in.)

2 in. - $3 \frac{15}{16}$ in. = nominal to -.025 mm (-.0010 in.)

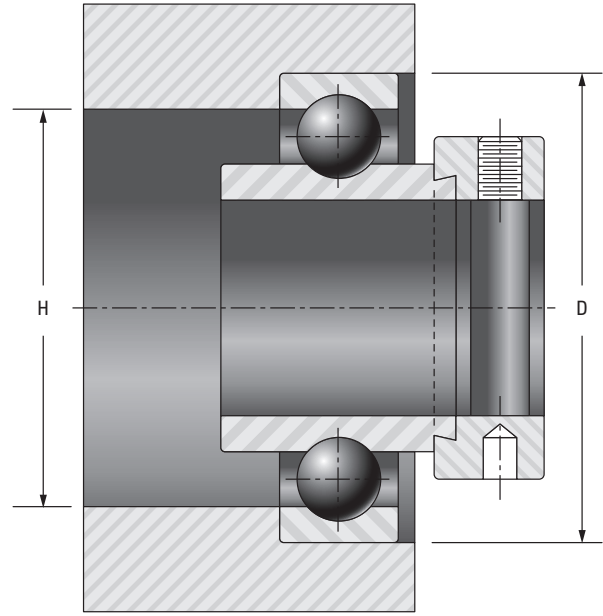

Fig. 49. Wide inner ring ball bearing.

Housing, shoulders and shaft diameters

Bearing Number					Shaft Size	Basic Outer Ring Size	Housing Stationary ⁽¹⁾			Shoulder Diameter, H	
KRR Type	G-KRR Type	RA-RR Type	GRA-RR Type	GYA-RR ⁽²⁾ Type			Housing Bore, D		Mean Fit	Max.	Min.
							Max.	Min.	Loose		
					mm in.	mm in.	mm in.	mm in.	mm in.		
1008KRR	—	RA008RR	GRA008RR	GYA008RR	1/2	203	40.015 1.5754	40.000 1.5748	0.013 0.0005	34.8 1.37	34.0 1.34
—	—	RA009RR	GRA009RR	GYA009RR	9/16						
1010KRR(KR)	G1010KRR	RA010RR	GRA010RR	GYA010RR	5/8						
1011KRR	G1011KRR	—	—	—	11/16						
E17KRR	GE17KRR	RAE17RR	GRAE17RR	GYAE17RR	17	204	47.015 1.8510	47.000 1.8504	0.013 0.0005	40.9 1.61	40.6 1.60
1012KRR(KR)	G1012KRR	RA012RR	GRA012RR	GYA012RR	3/4						
E20KRR	GE20KRR	RAE20RR	GRAE20RR	GYAE20RR	20	205	52.017 2.0479	51.999 2.0472	0.015 0.0006	46.0 1.81	45.7 1.80
1013KRR	—	RA013RR	GRA013RR	GYA013RR	13/16						
1014KRR	G1014KRR	RA014RR	GRA014RR	GYA014RR	7/8						
1015KRR(KR)	G1015KRR	RA015RR	GRA015RR	GYA015RR	15/16						
1100KRR(KR)	G1100KRR	RA100RR	GRA100RR	GYA100RR	1	206	62.017 2.4416	61.999 2.4409	0.015 0.0006	56.1 2.21	54.9 2.16
E25KRR	GE25KRR	RAE25RR	GRAE25RR	GYAE25RR	25						
—	G1101KRR	RA101RR	GRA101RR	GYA101RR	1 1/16						
1102KRR(KR)	G1102KRR	RA102RR	GRA102RR	GYA102RR	1 1/8						
1103KRR(KR)	G1103KRR	RA103RR	GRA103RR	GYA103RR	1 3/16	206	62.017 2.4416	61.999 2.4409	0.015 0.0006	56.1 2.21	54.9 2.16
—	—	—	—	GYA103RR2	1 1/4						
E30KRR	GE30KRR	RAE30RR	GRAE30RR	GYAE30RR	30						

⁽¹⁾ When the housing revolves in relation to the shaft, housing bore dimensions shown on pages 130-133 should be used. Outer ring tolerances and housing fillet radii correspond to equivalent 200 Series single row radial bearings.

⁽²⁾ Available as non-relubricatable type (omit Prefix "G").

Continued on next page.

Housing, shoulders and shaft diameters

Bearing Number					Shaft Size	Basic Outer Ring Size	Housing Stationary ⁽¹⁾			Shoulder Diameter, H	
KRR Type	G-KRR Type	RA-RR Type	GRA-RR Type	GYA-RR ⁽²⁾ Type			Housing Bore, D		Mean Fit	Max.	Min.
							Max.	Min.	Loose		
					mm in.	mm in.	mm in.	mm in.	mm in.		
1104KRR(KR)	G1104KRR	RA104RR	GRA104RR	GYA104RR	1 1/4	207	72.017 2.8353	71.999 2.8346	0.015 0.0006	56.1 2.56	54.9 2.47
1105KRR	—	RA105RR	GRA105RR	GYA105RR	1 5/16						
1106KRR	G1106KRR	RA106RR	GRA106RR	GYA106RR	1 3/8						
1107KRR(KR)	G1107KR	RRA107RR	GRA107RR	GYA107RR	1 7/16						
E35KRR	GE35KRR	RAE35RR	GRAE35RR	GYAE35RR	35						
1108KRR(KR)	G1108KRR	RA108RR	GRA108RR	GYA108RR	1 1/2	208	80.018 3.1503	80.000 3.1496	0.020 0.0006	78.0 2.87	75.4 2.78
—	—	RA106RR	GRA109RR	GYA109RR	1 9/16						
—	—	—	GRAE40RR	GYAE40RR	40						
1110KRR	G1110KRR	RA110RR	GRA110RR	GYA110RR	1 5/8	209	85.024 3.3474	85.001 3.3465	0.020 0.0008	78.0 3.07	75.4 2.97
1111KRR(KR)	G1111KRR	RA111RR	GRA111RR	GYA111RR	1 11/16						
1112KRR(KR)	G1112KRR	RA112RR	GRA112RR	GYA112RR	1 3/4						
E45KRR	—	—	GRAE45RR	GYAE45RR	45						
—	—	RA113RR	GRA113RR	GYA113RR	1 13/16	210	90.023 3.5442	90.000 3.5433	0.020 0.0008	83.1 3.27	81.0 3.19
1114KRR	—	RA114RR	GRA114RR	GYA114RR	1 7/8						
1115KRR(KR)	G1115KRR	RA115RR	GRA115RR	GYA115RR	1 15/16						
—	—	—	GRA115RR2	—	2						
E50KRR	GE50KRR	RAE50RR	GRAE50RR	GYAE50RR	50						
1200KRR(KR)	G1200KRR	RA200RR	GRA200RR	GYA200RR	2	211	100.023 3.9379	100.000 3.9370	0.020 0.0008	90.9 3.58	90.4 3.56
—	—	RA201RR	GRA201RR	GYA201RR	2 1/16						
1202KRR	—	RA202RR	GRA202RR	GYA202RR	2 1/8						
1203KRR(KR)	G1203KRR	RA203RR	GRA203RR	GYA203RR	2 3/16						
E55KRR	GE55KRR	RAE55RR	GRAE55RR	GYAE55RR	55						
1204KRR	—	—	—	—	2 1/4	212	110.02 4.3316	110.000 4.3307	0.020 0.0008	101.1 3.98	98.3 3.87
1207KRR(KR)	G1207KRR	—	—	—	2 7/16						
E60KRR	GE60KRR	—	—	—	60						
1215KRR	—	—	—	—	2 15/16	215	130.025 5.1191	130.000 5.1181	0.023 0.0009	120.9 4.76	116.6 4.59
E75KRR	—	—	—	—	75						

⁽¹⁾ When the housing revolves in relation to the shaft, housing bore dimensions shown on pages 130-133 should be used. Outer ring tolerances and housing fillet radii correspond to equivalent 200 Series single row radial bearings.

⁽²⁾ Available as non-relubricatable type (omit Prefix "G").





MAINTENANCE TOOLS

K

K MAINTENANCE TOOLS

Maintenance Tools	145
Mounting Tools	145



MAINTENANCE TOOLS

K

K

MAINTENANCE TOOLS

Convenient handling devices give technicians the tools they need to properly and more easily install, remove and service bearings, which is essential to ensure long bearing life and may prevent unnecessary damage. Timken products available to help customers safely handle bearings include impact fitting tools, induction heaters, and mechanical, hydraulic and self-centering pullers. Impact tools are used to forcefully drive bearing components on or off shafts, or in or out of housings. Timken induction heaters can be used for heating gear wheels, bushings, couplings and other components to aid installation. Pullers are ideal for removing all kinds of shaft-fitted parts easily.

MOUNTING TOOLS

Removing and installing bearings can be made easier using a variety of installation tools. This is especially true for bearings installed with tight or interference fits that can be difficult to install and remove.

Induction heaters

Induction heaters provide a fast, controlled heating method that does not create the smoke, fumes or oil waste caused when using other methods. This makes induction heaters a more environmentally friendly method.



Fig. 50. Two yokes can be combined to heat the bearing bore.

These heaters come in various sizes, and a heater may also come with different sized yokes. Choose a yoke size that fills the bore of the bearing as fully as possible. You can also combine two yokes to heat the bearing more quickly and evenly (Fig. 50).

Induction heaters work very quickly. Take care to avoid heating the bearing with seals to temperatures higher than 90°C (200°F). Consult your induction heater manual for proper temperature and time setting guidelines. Trial runs with the induction heater and bearings are generally necessary to determine the proper timing. Thermal crayons that melt at predetermined temperatures can be used to monitor the bearing temperature.

Place the heater probe as close as possible to the bore of the work piece. Ensure that the area where the probe is located is completely clean. Handle the probe with care. It is a valuable part of the heater and can easily break.

Ensure that the heating and demagnetization cycle is complete before removing the work piece.

⚠ CAUTION Failure to observe the following cautions could create a risk of injury:

If the bearing is to be reused or returned for repair, do not use heat from a torch. Extreme heat from a torch can alter the bearing hardness and metallurgical structure, resulting in irreparable damage.



Impact tools

Impact tools are used to forcefully drive bearing components on or off shafts, or in or out of housings. It is not recommended that they be used with bearing assemblies. The tools should be made of materials that will not nick or damage shafts and housings. These materials may include soft metals or impact resistant plastic.

When using impact tools, use caution to avoid missed strikes that allow the hammer to come into contact with the shaft or housing.

Hydraulic nuts

Hydraulic nuts can be used to speed and ease the installation and removal of tapered bore bearings. The pressure generated by the piston creates a smooth, controllable force to enable precise positioning of the bearing on the shaft. These nuts provide better control of the bearing internal clearance reduction, while reducing the chance of damaging the bearing or other components.

Pullers

There are a variety of hand and hydraulic pullers (Fig. 51 and 52) available that can be used to pull bearings, bushings, gear wheels, couplings or other press-fitted work pieces. Hydraulic pulling devices can usually apply more force than hand pullers.

When using hydraulic or hand pullers:

- Select the proper size and capacity puller for the job.
- Make sure the puller capacity exceeds calculated maximum withdrawal forces.
- Ensure the puller legs are properly secured around the work piece. Each leg must be fully engaged.
- Always apply force gradually.
- On hand pullers, do not use a hammer when operating the spindle.

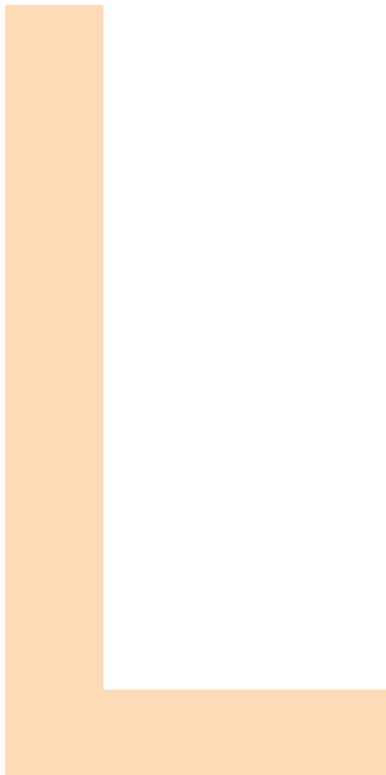

Fig. 51. Puller.



Fig. 52. Puller.

LUBRICATION AND SEALS



L LUBRICATION AND SEALS

Lubrication	149
Oils	149
Grease Lubrication.....	151
Grease Selection	153
Special Applications.....	154
Seals	158
Installation Methods	159



LUBRICATION AND SEALS

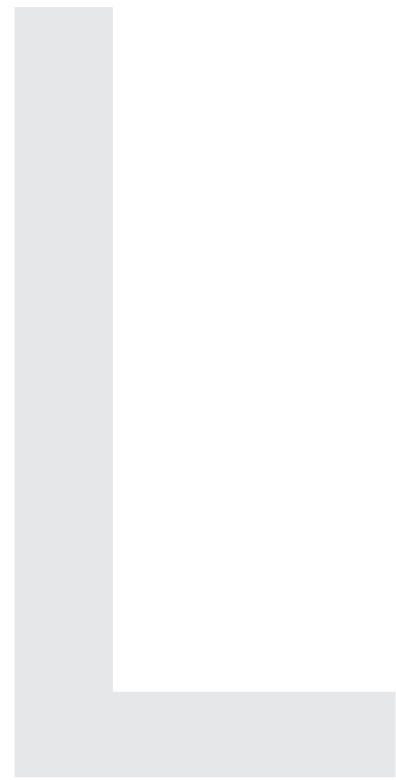

LUBRICATION

Using our knowledge of tribology, anti-friction bearings and total system performance needs, Timken has developed a complete line of application- and environment-specific lubricants.

Timken offers a range of lubricants to help bearings and related components operate effectively in demanding industrial operations. High-temperature, anti-wear and water-resistant additives offer greater protection in challenging environments. Timken also offers a line of single- and multi-point lubricators to simplify the delivery of grease.

Most bearings used in general industrial and precision applications do not reach their fatigue life goal for a variety of reasons. Proper lubrication is essential to achieve optimum equipment performance, minimum equipment downtime and the longest possible bearing life.

When a properly lubricated bearing rotates, the mating surfaces of the bearing components create a lubricant film that keeps the components separated. The lubricant:

- Provides a suitable film that prevents metal-to-metal contact and separates the moving parts in a bearing
- Carries away heat
- Protects the bearing surfaces from corrosion

In some cases, the lubricant can also trap debris, carrying it away from the contact surfaces.

The correct lubricant for each application depends on the bearing design and the operating conditions. The wide range of bearing types and operating conditions precludes any simple, all-inclusive guidelines regarding lubricant selection and use. However, an understanding of the characteristics and advantages of the various lubricants available can be helpful in implementing appropriate lubrication-related maintenance.

The lubrication requirements of all Timken bearings used in general industrial applications can be met with high quality petroleum lubricants. However, synthetic lubricants are gaining considerable popularity, especially where high operating temperatures and long service life is required.

New Timken bearings are protected with a preservative coating. The preservative coating is compatible with most lubricants, so it is not necessary to wash it off prior to installation. Bearings that are not pre-lubricated, however, will require proper lubrication as part of the installation process.

Lubricant types can be broadly divided into two groups; oil or grease. Each has its advantages (Table 4).

Oil	Grease
Carries heat away from the bearings	Simplifies seal design and acts as a sealant
Carries away moisture and particulate matter	Permits prelubrication of sealed or shielded bearings
Easily controlled lubrication	Generally requires less frequent lubrication

Table 4. Advantages of oil and grease.

OILS

Oil Types

Oils are classified as either petroleum or synthetic. Petroleum oils are refined from crude oil and synthetic oils are produced by chemical synthesis.

The primary characteristic when selecting an oil is its viscosity, a measure of its flow characteristics. Viscosity is normally expressed in terms of the time required for a specific amount of oil to flow through a standard size hole at a specific temperature. Viscosity varies with temperature and is always described with the temperature at which it was measured.

The International System (S.I. units) for classifying viscosity uses centistokes at standard temperatures of 40°C (104°F) and 100°C (212°F). The Saybolt Universal Second (SUS) is also commonly used in many parts of the world. The standard measuring temperature for SUS is 40°C (100°F) and 100°C (210°F).

There are many classifications for oil viscosity grades. The most familiar is the Society of Automotive Engineers (SAE) system, which includes automotive engine and gear oils for conventional crankcases (Fig. 53) and manual transmission oils (Fig. 54).

The American Society of Testing and Materials (ASTM) has adopted a standard of viscosity grades for industrial fluids, known as the ISO viscosity grade. This system shows the viscosity grade as the numerical viscosity of the fluid in centistokes at 40°C (104°F) (Fig. 55). These two viscosity classification systems can be directly compared (Fig. 56).

When selecting the correct oil for an application, the bearing size, speed, temperature, load and general operating condition must all be considered. Consult with your lubricant supplier or equipment manufacturer for specific questions about lubrication requirements for a piece of equipment. You can also contact your Timken representative for general lubrication guidelines for any application.

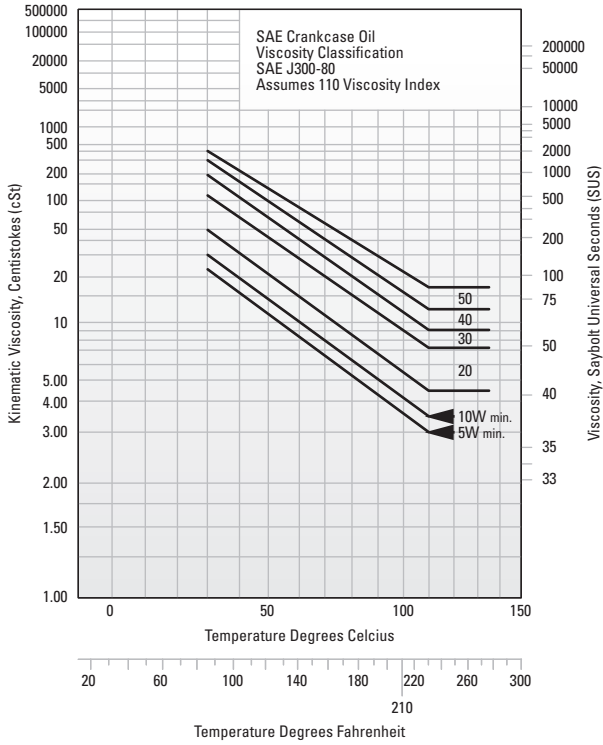

Fig. 53. Automotive engine and gear oils.

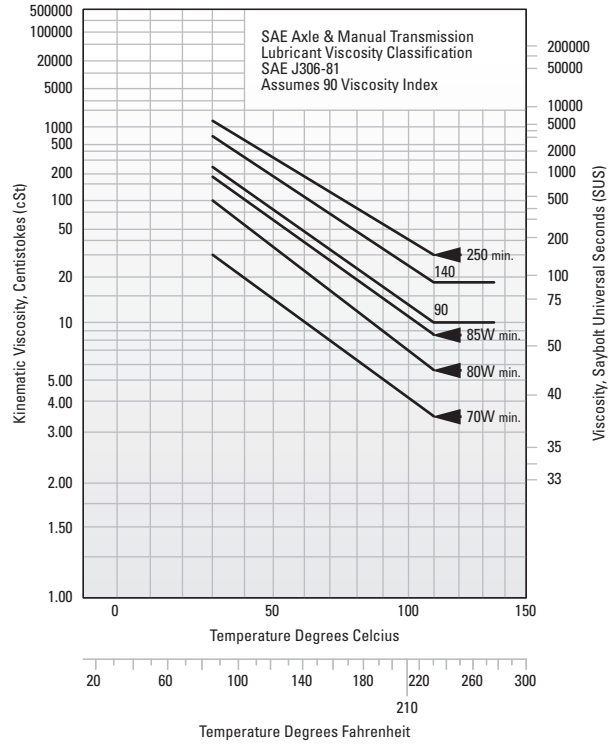

Fig. 54. Manual transmission oils.

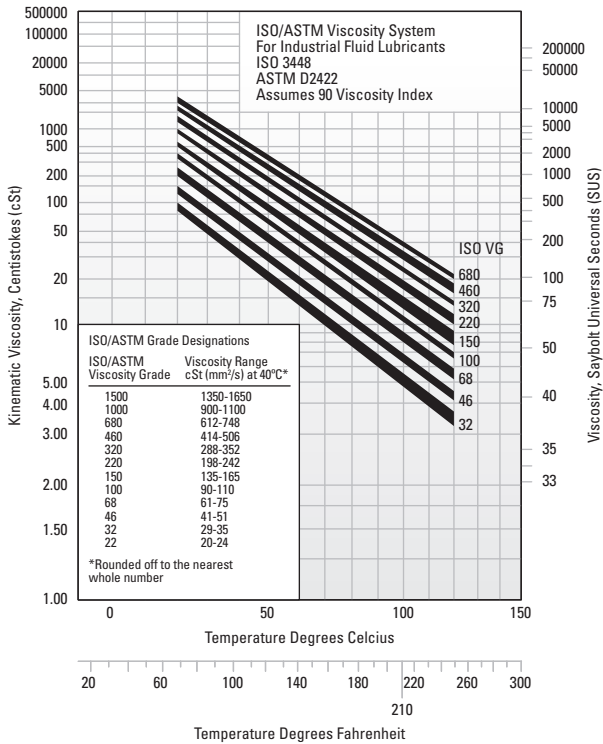

Fig. 55. ISO Viscosity system.

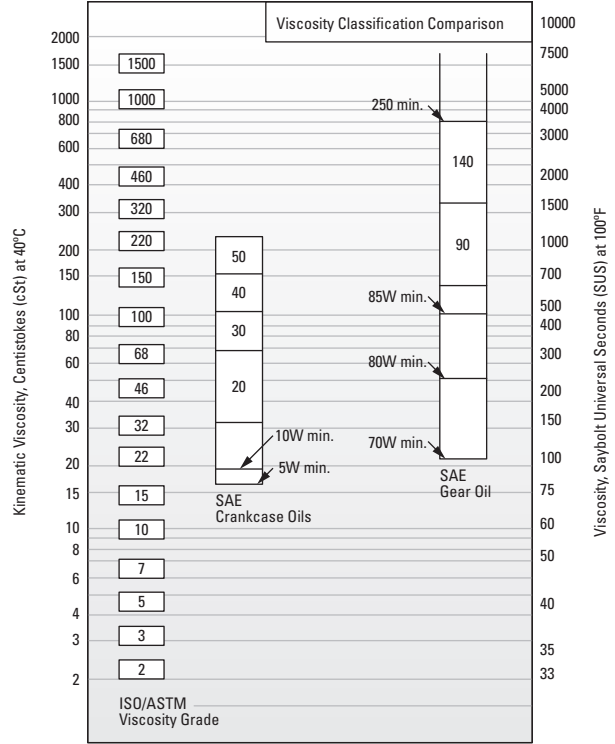

Fig. 56. Comparison of viscosity systems.

Oil advantages

Where heat must be carried away from the bearing, oil must be used, and it is nearly always preferred for very high-speed applications. Other relevant features and advantages of oil lubrication include:

- Oil is a better lubricant for high speeds or high temperatures, and can be cooled to help reduce bearing temperature.
- Oil is easier to handle and to control the amount of lubricant reaching the bearing, but it is harder to retain in the bearing. Lubricant losses may be higher than with grease.
- As a liquid, oil can be introduced to the bearing in many ways such as drip-feed, wick feed, pressurized circulating systems, oil bath or air-oil mist. Each is suited to certain types of applications.
- Oil is easier to keep clean for recirculating systems.

Oil delivery systems

Oil may be introduced to the bearing in many ways. The most common systems are:

Oil bath: The housing is designed to provide a sump or reservoir that the bearing rolling elements rotate through. Generally, the oil level is no higher than the center point of the lowest rolling element, as measured when the bearing is stationary. In high-speed applications, lower oil levels are used to reduce churning. Gages or controlled elevation drains are used to achieve and maintain the proper oil level.

Circulating system: A typical oil system consists of an oil reservoir, pump, piping and filter. A cooler may also be required. These systems ensure an adequate supply of oil for both cooling and lubrication. Contaminants and moisture are removed from the bearing by the flushing action of the oil, and filters trap contaminants.

It is relatively easy to direct lubricant to multiple bearings in the application. The relatively large oil reservoir reduces lubricant deterioration, increasing lubricant life and system efficiency.

Oil-mist: These systems are used in high speed and continuous operation applications such as steel mill bearings and high-speed machines. They permit close control of the amount of lubricant reaching the bearings and use relatively little oil. The oil may be metered, atomized by compressed air and mixed with air, or it is picked up from a reservoir using a Venturi Effect.

The air is filtered and supplied under sufficient pressure to provide adequate bearing lubrication. The system is typically controlled by monitoring the bearing operating temperature.

The continuous flow of pressurized air and oil through the labyrinth seals in the system prevents the entrance of contaminants. Successful oil mist systems require:

- Proper location of the lubricant entry ports in relation to the bearings being lubricated.
- Avoiding excessive pressure drops across void spaces within the system.
- Proper air pressure and oil quantity ratio for the application.
- Adequate exhaust of the air-oil mist after lubrication has been accomplished.

To ensure wetting of the bearings and to prevent possible damage to the rolling elements and races, it is imperative that the oil-mist system be turned on for several minutes before the equipment is started. The importance of wetting the bearing before starting cannot be overstated, especially for equipment that has been idled for extended periods of time.

GREASE LUBRICATION

Lubricating grease is a solid-to-semi fluid product that includes a thickening agent dispersed in a liquid lubricant. The thickener acts as a sponge and releases oil under load to lubricate the bearing. Additional additives are typically included to change the performance or characteristics of the grease.

There is no universal bearing grease. Each individual grease has certain limiting properties and characteristics. Table 6 shows some of the primary characteristics for each of the most common grease types. The dropping point is the temperature at which the grease liquifies. Some greases are reversible and will reconstitute after the temperature cools to below the dropping point. Other greases will not.

In addition to these traditional greases, synthetic lubricating fluids such as esters, organic esters and silicones are capable of performing at temperatures as low as -70°C (-100°F) to as high as 290°C (550°F).

Regarding the thickeners, polyurea is a significant lubrication development. Polyurea grease performance is outstanding in a wide range of bearing applications, and in a relatively short time has gained acceptance as a factory packed lubricant for ball bearings.

Consistency

Greases may vary in consistency from semi-fluids hardly thicker than viscous oil to solid grades almost as hard as a soft wood. The consistency of the grease and its ability to remain stable, both mechanically and chemically during operation, are important traits.

Consistency is measured by a penetrometer in which a standard weighted cone is dropped into the grease. The distance the cone penetrates (measured in tenths of a millimeter over a specific time) is the penetration number (Table 5). The National Lubricating Grease Institute (NLGI) has classified greases according to consistency as measured by a penetrometer. These numbers indicate the consistency of the grease. Timken bearings generally use a No. 1 or No. 2 consistency grease. Greases heavier than No. 2 are seldom used because they tend to channel and result in possible lubricant starvation.

NLGI Number	Penetration Range
000	445 - 475
00	400 - 430
0	355 - 385
1	310 - 340
2	265 - 295
3	220 - 250
4	175 - 205
5	130 - 160
6	85 - 115

Table 5. Grease penetration ranges by NLGI number.

Grease consistency is not fixed; it normally becomes softer when sheared or worked. It also becomes thicker at lower temperatures and more fluid at higher temperatures. Starting torque at low temperatures can present a problem. In smaller machines, starting may be impossible when very cold. Under these operating conditions, use greases with good low-temperature characteristics.

If the operating temperature range is wide, synthetic fluid greases offer definite advantages. Greases are available to provide very low starting and running torque at temperatures as low as -70°C (-100°F). In certain instances these greases perform better in this respect than oil.

Thickener	Typical Dropping PT	Usable Temperature ⁽¹⁾	Typical Water Resistance
	°C °F	°C °F	
Sodium Soap	260 + 500 +	121 250	Poor
Lithium Soap	193 380	104 220	Good
Polyurea	238 460	149 300	Excellent
Lithium Complex Soap	260 + 500 +	163 325	Good

NOTE: The properties of a grease may vary considerably depending on the particular oil, thickener and additives used in the formulation.

⁽¹⁾ Continuous operation with no relubrication. Depending upon the formulation the service limits may vary. The usable limit can be extended significantly with relubrication.

Table 6. Usable temperature by thickener type.

Temperature and grease life

Greases are rated to perform up to certain upper temperature limits. The Usable Temperature (Table 6) is the temperature at which a bearing can continuously operate with no relubrication. Brief intervals of higher temperature operation will probably not result in any lubrication problems. Extended operation above the usable temperature can degrade the grease and result in premature bearing damage.

At the dropping point, the grease liquefies and no longer provides adequate lubrication. Some greases are reversible and will reconstitute after the temperature cools to below the dropping point. Other greases will not. The dropping point of the grease used should be at least 40°C (100°F) greater than the highest expected temperature in the application.

The high temperature limit for grease is generally a function of the thermal and oxidation stability of the lubricant and the effectiveness of oxidation inhibitors included in grease.

Synthetic greases are available where extremely high temperatures are experienced (Fig. 57).

As the temperature increases, viscous or hard residues are created that interfere with the operation of the bearing. In general, the higher the temperature the more rapidly the grease oxidizes. As a rule of thumb, grease life is halved for every 10°C (18°F) increase in temperature. For example, if a particular grease provides 2000 hours of life at 90°C (194°F), raising the temperature to 100°C (212°F) would reduce life to approximately 1000 hours. On the other hand, 4000 hours could be expected by lowering the temperature to 80°C (176°F).



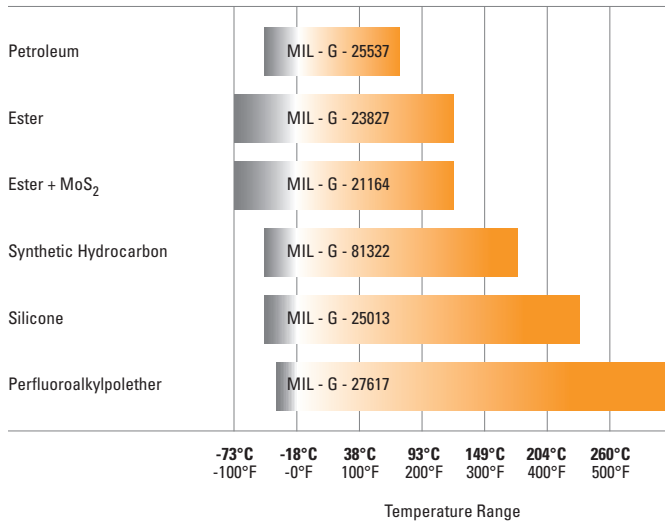

Fig. 57. Lubrication grease temperature ranges.

Wet conditions

Water and moisture can greatly accelerate bearing damage, but greases may provide a measure of protection from this contamination. Certain greases – calcium, lithium and non-soap type for example – are highly water resistant. However, these greases exhibit poor rust preventative characteristics unless properly inhibited.

Sodium soap greases emulsify (combine) with small amounts of moisture that may be present and prevent moisture from coming in contact with the bearing surfaces. In certain applications this characteristic may be advantageous. However emulsions are generally considered undesirable.

GREASE SELECTION

The successful use of bearing grease depends on the physical and chemical properties of the lubricant, its application, application conditions and environmental factors. Because the choice of grease for a particular bearing under certain service conditions is often difficult to make, you should consult with your lubricant supplier or equipment maker for specific questions about lubrication requirements for a piece of equipment. You can also contact your Timken representative for general lubrication guidelines for any application.

Timken offers a line of industrial greases formulated specifically for particular applications (see Lubrication Selection Guide, page 155) that can be interchanged with many commonly used industrial greases (see Timken Grease Interchange Guide, pages 156-157).



Fig. 58. Grease can easily be packed by hand.



Fig. 59. Mechanical grease packer.

Grease application methods

Grease, in general, is easier to use than oil in industrial bearing lubrication applications. Bearings that are initially packed with grease require only periodic relubrication to operate efficiently.

Grease should be packed into the bearing so that it gets between the rolling elements – the rollers or balls. For tapered roller bearings, forcing grease through the bearing from the large end to the small end will ensure proper distribution.

Grease can be easily packed into small- and medium-size bearings by hand (Fig. 58). In shops where bearings are frequently regreased, a mechanical grease packer that forces grease through the bearing under pressure may be appropriate (Fig. 59). Regardless of the method used, after packing the internal areas of the bearing, a small amount of grease should also be smeared on the outside of the rollers or balls.

Regreasing timing and amount

The two primary considerations that determine the relubrication cycle are operating temperature and sealing efficiency. The less efficient the seals, the greater the grease loss and the more frequently grease must be added.

Grease should be added any time the amount in the bearing falls below the desired amount. The grease should be replaced when its lubrication properties have been reduced through contamination, high temperature, water, oxidation or any other factors. For additional information on appropriate regreasing cycles, consult with the equipment manufacturer or your Timken representative.

It is important to use the proper amount of grease in the application. In typical industrial applications, the voids in a roller bearing should be filled from one-third to two-thirds with grease. Less grease will result in the bearing being starved for lubrication. More grease may create churning which generates additional heat.

As the grease temperature rises, its viscosity decreases and becomes thinner. This can reduce the lubricating effect while increasing leakage of the grease from the bearing. It may also cause the grease components to separate, causing the grease to break down. Also, as the bearing heats up, the grease will expand somewhat and be purged from the bearing.

However, in low speed applications where temperature is not an issue, the housing can be entirely filled with grease. This safeguards against the entry of contaminants.

For best results, there should be ample space in the housing to allow room for excess grease to be thrown from the bearing. However, it is equally important that the grease be retained all around the bearing. If a large void exists between the bearings, grease closures should be used to prevent the grease from leaving the bearing area.

During periods of non-operation, it is often wise to completely fill the housings with grease to protect the bearing surfaces. Prior to subsequent operation, the excess grease should be removed and the proper level restored.

Applications using grease lubrication should have a grease fitting and a vent at opposite ends of the housing near the top. A drain plug should be located near the bottom of the housing to allow purging the old grease from the bearing.

Prelubricated bearings

Prelubricated and sealed bearings are extensively used with much success in applications where:

- Grease might be injurious to other parts of the mechanism.
- Cost and space limitations preclude the use of a grease filled housing.
- Housings cannot be kept free of dirt and grit, water or other contaminants. Relubrication is impossible or would be a hazard to satisfactory use.
- Accessing the bearing to re-lubricate it would be difficult or impossible.

Prelubricated bearings are typically packed with greases having chemical and mechanical stability, and demonstrated long life characteristics.

SPECIAL APPLICATIONS

Many bearing applications require lubricants with special properties or lubricants formulated specifically for certain environments, such as:

- Friction oxidation (fretting corrosion)
- Chemical and solvent resistance
- Food handling
- Quiet running
- Space and/or vacuum
- Electrical conductivity

For assistance with these or other areas requiring special lubricants, contact your Timken representative.

Lubrication Selection Guide

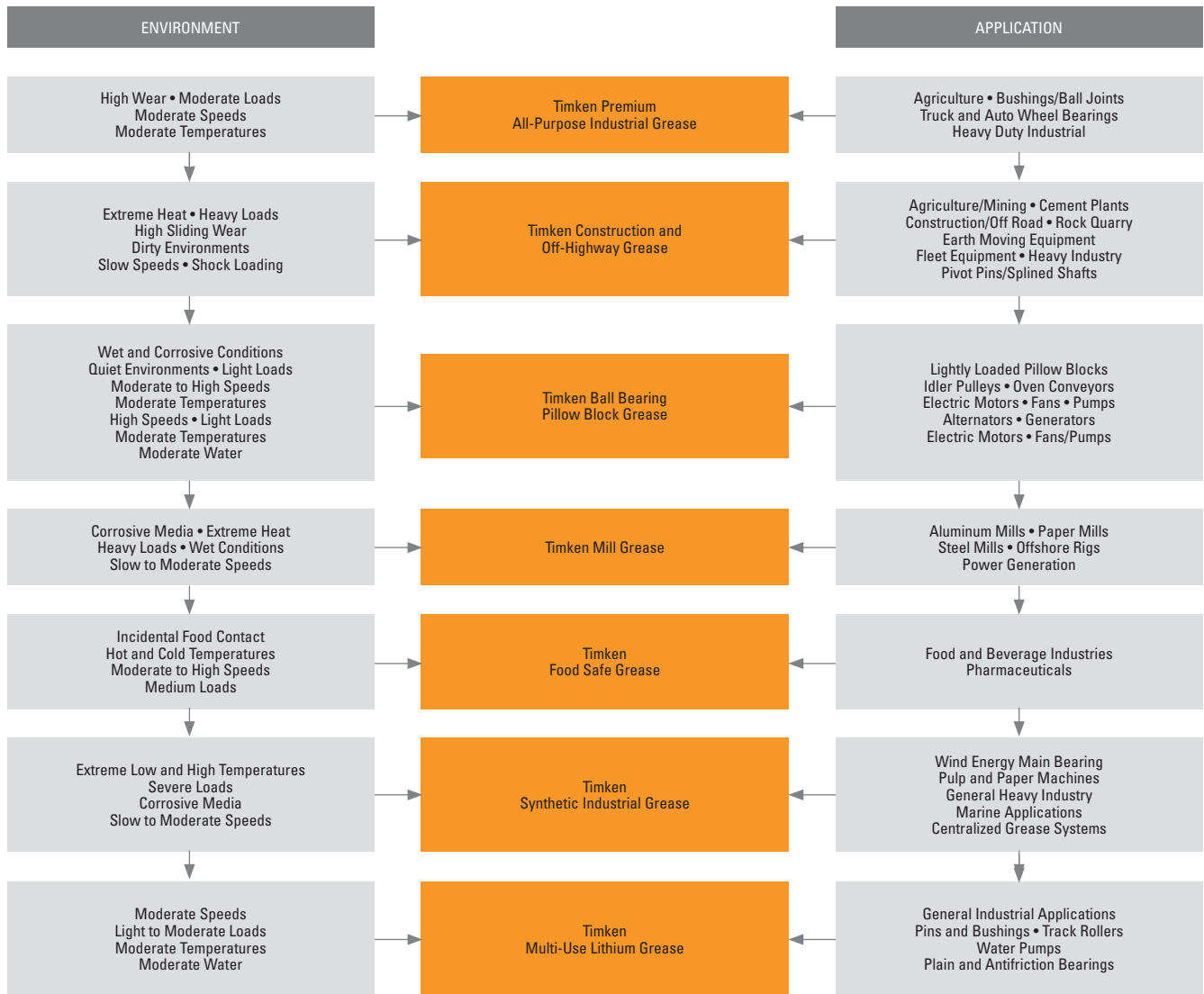

This selection guide is not intended to replace the specifications by the equipment builder who is responsible for its performance.



Timken Grease Interchange Guide

Timken Premium All Purpose Industrial Grease

Castrol 4020/220-2™
 Castrol 8060/220-2™
 Chevron Delo® EP 2
 Chevron RPM Automotive
 LC Grease EP-2™
 Citgo Lithoplex MP2™
 Citgo Premium
 Lithium EP 2™
 Conoco Super-STA® 2
 Exxon Ronex MP™
 Exxon Unirex EP 2™
 FAG LOAD220™
 Fuchs (Century) Uniwrl 2™
 Lubrication Engineers
 Almagard® 3752
 Lubriplate® 1552
 Mobilgrease® XHP 222
 Pennzoil® Pennlith® EP 712
 Pennzoil® Premium
 Lithium Complex 2
 Petro-Canada
 Multipurpose EP 2™
 Royal Purple®
 Ultra-Performance® 2
 Shell Albida® LC 2
 Shell Retinax® LC 2
 SKF LGWA2™
 SKF LGEP2™
 Texaco Starplex® 2
 Unical 76 Multiplex Red™

Timken Construction and Off-Highway Grease

Castrol Moly 860-2ES™
 Castrol Contractor Grease 2™
 Conoco Superlube M EP™
 D.A. Stuart Molyplex EP 2™
 Exxon Centaur Moly™
 Exxon Ronex Extra Duty Moly™
 Fuchs Moreplex 2™
 Lubriplate® 3000
 Mobilgrease® Moly 52
 Mystik® Tetrimoly® Extreme
 Pennzoil® Multipurpose EP 302
 Pennzoil® Premium
 Lithium Complex 2 with Moly
 Petro-Canada
 Precision Moly EP 2™
 Schaeffer Moly Ultra
 Supreme 238™
 Shell Retinax CMX 2™
 Texaco Starplex® Moly MPM2
 Unical 76 Megaplex™

Timken Ball Bearing Pillow Block Grease

Citgo Polyurea MP2™
 Conoco Polyurea 2™
 Exxon Polyrex® EM
 Exxon Unirex N™
 Mobilgrease® AW2
 Shell Alvania RL3™
 SKF LGHP2™
 Unocal 76 Unolife
 Grease™

Timken Ball Bearing Electric Motor Grease

Conoco Polyurea 2™
 Chevron SRI™
 Citgo Polyurea 2™
 Lubriplate® EM
 Petro-Canada EMB™
 Shell Dolium® BRB

Timken Food Safe Grease

SKF LGFP2™
 FAG Arcanol FOOD2™
 Keystone Nevastane HT/AW2™
 LE 4025 H1 Quinplex™
 LPS ThermaPlex Foodlube™
 Lubriplate® FGL-2
 Mobilgrease® FM 102
 Petro-Canada Purity FG™
 Royal Purple®
 Ultro-Performance®
 Clear FDA Grease

Timken Ultra-High Speed Spindle Grease

Kluberspeed BF 72-22™
 FAG Arcanol L-75™
 FAG Arcanol Speed 2,6™
 LubCon Highspeed L252™
 SKF LGCT2™

Timken Mill Grease

Castrol Moluballoy 777-2ES™
 Chem and Lube Black Magic™
 Chevron Ultiplex EP 2™
 Conoco HD Calcium™
 Conoco Milube™
 Exxon Ronex Extra Duty 2™
 FAG Arcanol Load 400™
 Kyodo Yushi Palmax RBG™
 Loctite ViperLube™
 Lubriplate® 1444
 Shell Retinax® Grease HD
 SKF LGHB2™

Timken Synthetic Industrial Grease

Mobilith SHC™ 460
 Chevron Ultiplex Synthetic Grease EP™
 Conoco SynCon Extra Long Life™
 Mobil SHC® PM
 Shell Albida® 460
 Texaco Starfak® PM

Timken Multi-Use Lithium Grease

Castrol Longtime PD™
 FAG Arcanol MULTI2™
 Lubriplate® 1200-2
 Lubriplate® 1241, 1242
 Lubriplate® 630-AA
 Mystik® Power Red
 Lithium C
 SKF LGMT2™



SEALS

Seals are critical with grease lubrication because they help keep the grease free from contamination. Contamination that reaches grease is trapped and will continually wear on the bearing.

Most seals are designed to prevent contaminants from entering the bearing. Some seals are designed to allow some grease to escape from the bearing, or “weep.” With these types of seals, the weeping action allows the grease to carry some of the contaminants out of the bearing. The grease that escapes from the bearing helps lubricate the seal, and forms an additional barrier to contamination.

Equipment Inspection and Preparation

Before installing any lip seal, equipment should be thoroughly inspected. Follow the specifications below for best results:

Shaft surface finish (roughness average or AA [arithmetic average])

- With the exception of PS-1 (Model 61), all seals should have a surface finish within 0.25-0.50 μm (10-20 $\mu\text{in.}$).
- For PS-1 (Model 61), the surface finish should be within 0.10-0.20 μm (4-8 $\mu\text{in.}$).
- The surface finish direction for all seals must be perpendicular to the shaft axis of rotation.

Housing bore surface finish, R_a (roughness average or AA [arithmetic average])

- The surface finish of all seals must be 2.54 μm (100 $\mu\text{in.}$).
- The surface finish direction for all seals must be perpendicular to the shaft axis of rotation.

Shaft surface hardness, Rockwell C-scale

- For all seals, with the exception of PS-1 (Model 61), the shaft contact surface should have a hardness between 30-40 Rockwell C.
- For PS-1 (Model 61), the surface hardness must be within 50-70 Rockwell C.

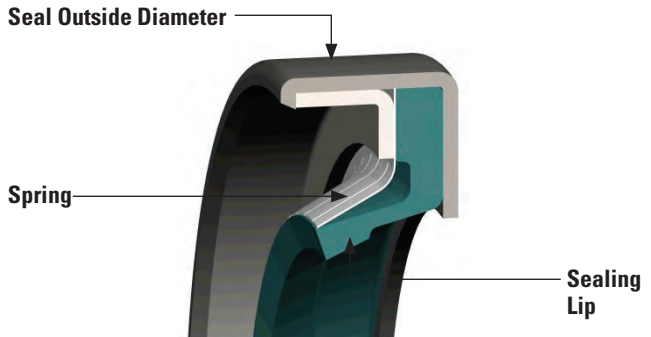

Fig. 60. Parts of a seal.

Additional specifications

- Both the shaft and housing bore should include an edge relief (preferably an edge chamfer).
- Both the shaft and housing bore should be clear of any defects, such as spiral-machining marks, burrs, sharp edges, nicks, scratches and corrosion.
- Typically, the shaft has a wear groove created from previous seals. Make sure the new sealing lip does not seal in the same location.
- When drive features such as keyways or splines are present, they must be covered using an installation tool similar to the one shown in Fig. 61, and using “Installation Method D” shown in Fig. 61. If the use of a tool is prohibited by the size of the shaft, use one of the following options:
 - Polyethylene tape
 - Brass shim stock with smooth edges
 - Wooden plug with smooth edges
- Inspect the sealing lip for any signs of damage, such as cuts, indentations and nicks.
- Make sure that the spring (finger or garter type) is retained within the seal (bonded or assembled).
- Inspect the seal O.D., looking for any signs of damage, such as cuts (in rubber seals), indentations and nicks.

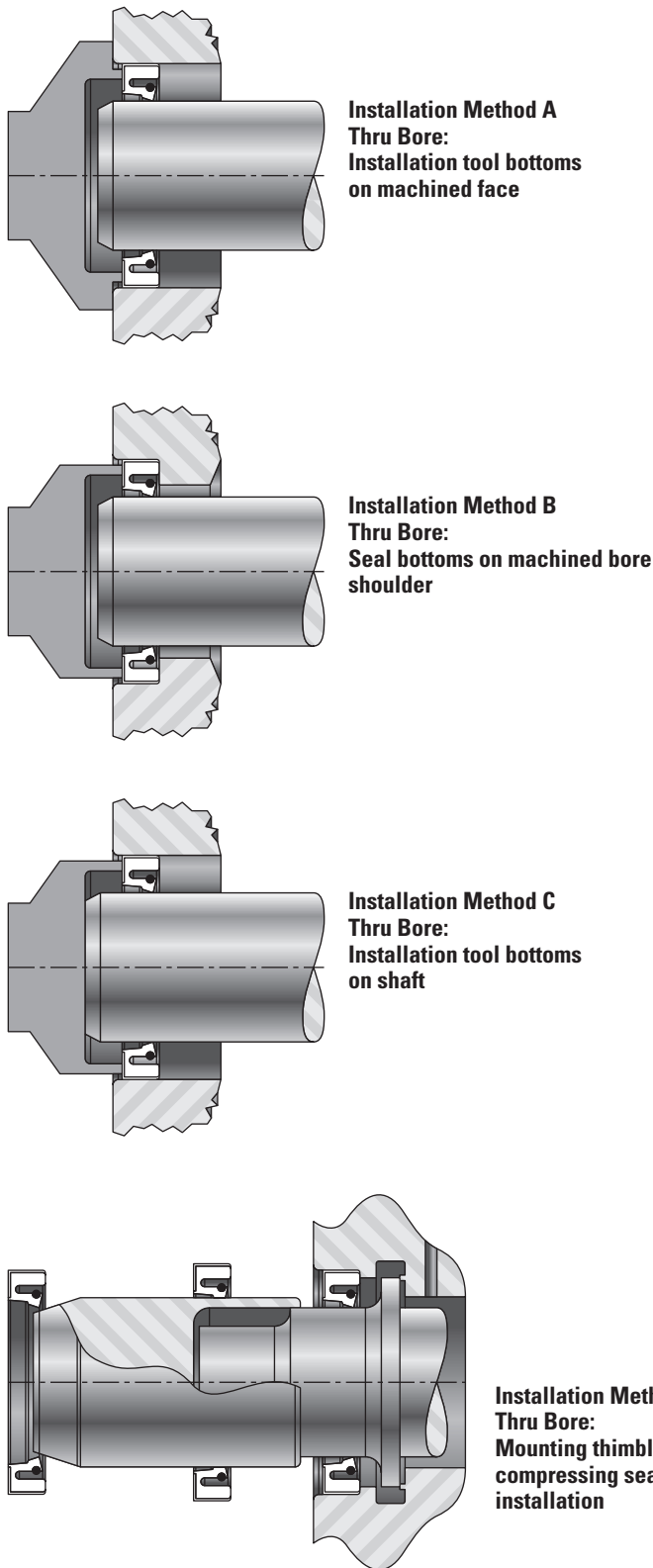

Fig. 61. Installation methods.

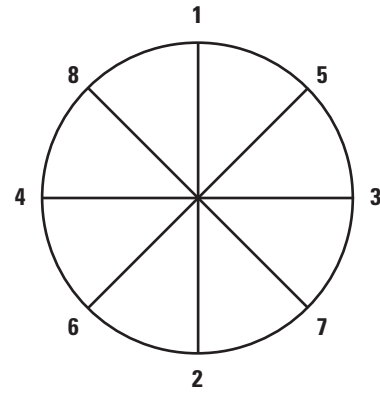

Fig. 62. Follow star pattern to avoid “cocking” of the seal.

INSTALLATION METHODS

Solid seal installation

Install the seal(s) using one of the proper installation methods shown in Fig 61. When using installation tooling, the diameter, or contact area, should not be more than 0.010 in. (0.254 mm) smaller than the bore diameter. If the use of an installation tool is prohibited by the size of the seal, then:

- Rest a block of wood on the seal and use a mallet to drive the seal into position. Do not hit the seal directly with the mallet, as it may cause damage.
- When using this method, follow a star pattern (as shown in Fig. 62) to avoid “cocking” of the seal.
- Place the ends of the wooden block at positions 1 and 2 (as shown in Fig. 62).
- Hit the center of the board with the mallet.
- Continue by rotating the wooden block to the appropriate positions (3 and 4, 5 and 6, 7 and 8), hitting the center of the block with the mallet each time.
- Repeat the pattern until the seal is properly seated in the housing bore. The seal is fully seated when the difference between the seal surface and the housing surface is 0.254 mm (0.010 in.).

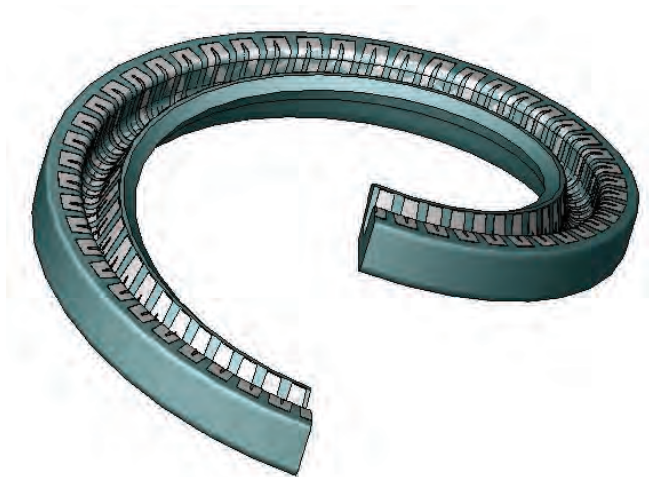

Fig. 63. Split the seal around the axis of rotation.

Split seal installation

NOTE: Ambient pressure/non-flooded applications only.

- Apply a thin coat of lubricant to the seal lip and shaft.
- Split the seal along the axis of rotation (shown in Fig. 63) and place the seal around the shaft.
- Beginning with the split ends, insert the seal into the housing bore. Make sure the splits ends of the seal are touching.
- Working downwards on both sides, continue inserting the seal into the housing bore, finishing at the bottom.
- Once the seal is properly seated in the housing bore, it should protrude from the housing surface by 0.381 mm (0.015 in.), as shown in Fig. 64. The 0.015 in. protrusion is built into the width of the seal. The depth of the bore housing should be machined to the seal width specified on the packaging.

Inspection

After installation, inspect the sealing areas for leaks, paying special attention to the area around the sealing lip and the O.D. Make sure that the sealing lip is not in the groove worn into the shaft from the previous seal.

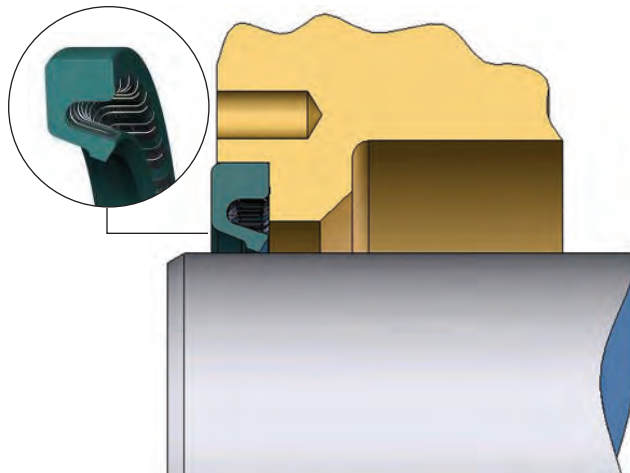

Fig. 64. The seal should slightly protrude from the housing surface.

Isolator installation

Before installing an isolator, all equipment should be inspected. First, disconnect all power to the machinery and follow standard safety procedures to avoid personal injury or equipment damage during installation.

Second, inspect the shaft and bore surfaces. The shaft finish should be better than $1.63\ \mu\text{m}$ ($64\ \mu\text{in}$) with minimal lead, but a polished surface is not required. The bore surface should be $2.54\ \mu\text{m}$ ($125\ \mu\text{in}$). Both the shaft and bore should have a chamfer or other edge relief to prevent the o-ring from shearing.

Third, check the shaft and bore for damage or imperfections. They should both be clear of burrs, nicks, indentations and any other defects. Clean all foreign debris from the area. Note that, in many cases, the previous seal may have worn a groove into the shaft. Make sure that the rotor o-ring of the new seal does not ride in this area.

Finally, if drive features such as keyways or splines are present on the shaft, they must be covered during installation. To do so, use an installation tool, polyethylene tape, brass shim stock with smooth edges or a wooden plug with smooth edges.

Seal preparation

Timken metallic and non-metallic bearing isolators are unitized, and any attempts to take them apart will not only cause seal damage, but will void the warranty on the product.

Before installation, inspect the o-ring's O.D. and I.D., making sure they are free of any defects. Use the lubricant included with your isolator to lightly grease all the o-rings.

Installation

Using your hands only (no installation tool required) push the isolator evenly onto the shaft.

If your isolator has a drain port, rotate it to the 6 o'clock position. For isolators with an orientation slot on the O.D. of the stator, rotate it to the 12 o'clock position to ensure appropriate positioning of the drain port. Some non-metallic bearing isolators may be installed in any direction, and there is no need to position the seal. See Fig. 65 for clarification, or contact your Timken sales representative if you require additional information.

Using your hands only (no installation tool required), push the isolator gently into the bore. If required, gently tap the isolator using a mallet. While flanged isolators are fully seated when the flange is flush against the housing, flangeless isolators can be installed at the bottom of the housing and are fully seated when they are flush with the bore face.

POST-INSTALLATION

Inspection

After installation, inspect the sealing area for damage. Gently spin the shaft to make sure the rotor is working properly. Do not flood the isolator or block the expulsion ports, as these actions can cause seal damage and failure.

Removal

To remove an old isolator from your equipment, start from the back side of the seal and perform installation instructions in reverse. If access to the back side of the isolator is difficult, pry it from the housing a little at a time. Be careful not to damage the shaft or housing bore during seal removal.

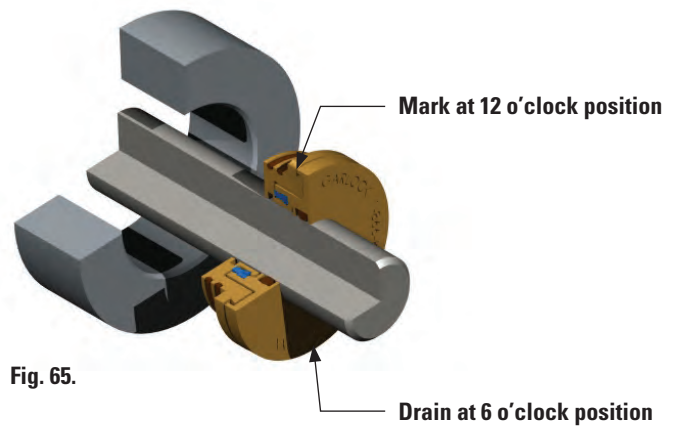

Fig. 65.





TIMKEN

Where You Turn

Bearings • Steel •
Precision Components • Lubrication • Seals •
Remanufacture and Repair •
Industrial Services

www.timken.com

Timken® is a registered trademark of
The Timken Company

© 2009 The Timken Company
Printed in Canada
XM 11-09-29 Order No. 10213